



High Voltage Variable Frequency Speed Control System

User Manual

Shenzhen INVT Electric CO., LTD.

Contents

Chapter 1 Precautions	5
1.1 Safety notes.....	5
1.2 Relevant design standards of the high voltage variable frequency speed control systems.....	6
Chapter 2 Product Overview	8
2.1 Technical features.....	8
2.2 Brief introduction of features.....	9
2.3 Product application fields.....	11
2.4 System composition and principle of work.....	11
2.4.1 System composition.....	11
2.5 Public technical parameters, specifications and models.....	13
2.5.1 Model description.....	13
2.5.2 Descriptions of data plate models.....	13
2.5.3 General parameters of the system.....	14
2.6 System profile and size parameters.....	15
2.6.1 System profile.....	15
2.6.2 System size parameters.....	16
Chapter 3 System transportation, storage and waste disposal	20
3.1 The transportation of high voltage variable frequency speed control systems.....	20
3.2 Arrival acceptance check.....	20
3.3 Storage and conditions.....	21
3.4 Storage of spare parts.....	21
3.5 Product waste treatment.....	21
Chapter 4 System Installation and Wiring	22
4.1 Installation of cabinet bodies.....	22
4.2 Installation of the high voltage parts.....	25
4.3 Wiring of user terminals.....	27
Chapter 5 System debugging and running	31
5.1 Items of detection and confirmation before debug running.....	31
5.2 Tests of Control cabinet power on and after power-on.....	31
5.3 Main loop power on and power-on debugging.....	32
5.4 Test with motors.....	33
Chapter 6 Operation of the variable frequency speed control system	34
6.1 Description of switch cabinet.....	34
6.2 Operation steps of variable frequency speed control system.....	35
Chapter 7 Human-machine interface	37
7.1 Keyboard.....	37
7.2 Touch screen.....	41
Chapter 8 Detailed Functional Description	44
Chapter 9 Warning information and fault solution	85
9.1 Fault and trouble shooting.....	85
9.2 Unit fault.....	87
9.3 The action after fault.....	88
9.4 Action after warning.....	88

9.5 Common Faults and Solutions	89
Chapter 10 Maintenance	90
Appendix 1	93
Appendix 2	95
Appendix 3	103

Introduction

Thank you for purchasing the high voltage variable frequency speed control system of our company. CHH Series high voltage variable frequency speed control systems are the multilevel high voltage variable frequency speed control systems manufactured by our company, and are applicable to 3-phase high voltage induction motors. Please read and comprehend the contents stated in this manual before use to ensure proper usage. Improper usage will result in abnormal running or the reduction of the service life.

This user manual is only applicable to the CHH Series High voltage variable frequency speed control systems of our company.

Please keep this manual with the variable frequency speed control system under safe custody for use whenever it is necessary.

Chapter 1 Precautions

1.1 Safety notes



Notes

- ◇ Before installation, wiring, running and maintenance inspections, you are required to get well acquaintance with the contents of this instruction manual, to ensure the proper using. It is also necessary to be familiar with the circumstances of the driven machinery and all relevant safety notes while using.

About usage



Notes

- ◇ The high voltage variable frequency speed control systems of this series are only applicable to 3-phase high voltage induction motors, and cannot be put into other applications, as it would result in danger.
- ◇ Under the circumstances of application where the failure of this product may cause accidents or loss, corresponding safety measures must be provided for emergencies.

About wiring



Notes

- ◇ A high voltage circuit breaker must be equipped at the power supply side of the high voltage frequency inverter for circuit protection.
- ◇ Reliable grounding is required.
- ◇ The wiring must be implemented under the guidance of the professionals of our company, according to the relevant electrical safety standards.
- ◇ The main body of the equipment must be installed in place before the wiring operations.
- ◇ It is required to confirm the consistency of the phase number of the input power and the rated input voltage with the ratings of the frequency inverter.
- ◇ The output terminals (U, V and W) must not be connected to AC power supplies.

About disposal



Warning

- ◇ The discarded parts and components shall be disposed of as industrial waste.

About handling



Warning

- ◇ While moving, transporting and placing the equipment, the location of the equipment shall be kept level and flat.
- ◇ While lifting the equipment, adequate lifting strength is required, with gentle liftings and landings.
- ◇ Please do not drop (leave) any thread, paper, metal fragments, tool or other foreign matters in the variable frequency speed control system.
- ◇ If any part of the variable frequency speed control system is damaged, please do not install or use the equipment.
- ◇ Guard rails shall be put up at the necessary places (with High voltage danger signs on them), and must not be removed during the operation.

About installation



Danger

- ◇ It is required to configure the grounding lines strictly in accordance with the requirement of the technical guidance in the manual and the national standard configurations.
- ◇ The wiring operation must be carried out by professional electrical technicians.
- ◇ The operation can only be carried out after confirming that the control circuit and the main circuit both have no voltage input.
- ◇ The I/O cables must be wired according to the instructions, and no error is allowed, otherwise the equipment may be damaged.
- ◇ Confirm that the input power supply complies with the requirement of the product technical specifications.
- ◇ The I/O lines must meet the requirement of insulation and capacity.
- ◇ The variable frequency speed control system shall be installed onto flame-retardant matters, e.g. metal stands, cement ground, etc.
- ◇ Flammable objects shall not be placed inside the cabinet of the variable frequency speed control systems or around them, including the equipment drawings, instruction manuals and others.

About operation



Warning

- ◇ The variable frequency speed control system can be connected to the power supply only after the electrical cabinet doors are all closed, and the cabinet doors must not be opened after the power supply is connected.
- ◇ The switch must not be operated with wet hands.
- ◇ When trip and reboot occurs, the peripheral system specially designed shall be able to guarantee personal and equipment safety.
- ◇ When the variable frequency speed control system is switched on, even if it is in the stopping status, the terminal may still be charged and must not be touched.
- ◇ The start-stops of the high voltage frequency inverter shall not be operated using the methods of connecting or disconnecting the main circuit.

1.2 Relevant design standards of the high voltage variable frequency speed control systems

The design and manufacturing of CHH Series high voltage variable frequency speed control systems refer to the latest version of national standards (GB or GB/T), the standards of International Electrotechnical Commission(IEC) and International System of Units (SI) as the lowest design technical indices, as well as the requirements of the national standards (GB or GB/T) and the standards of International Electrotechnical Commission (IEC) that the technical parameters of the relevant parts can meet.

Part of the technical standards referenced by the design

IEC 76	Power Transformers
IEC 529	European (ECC) water protection specifications
IEC 1131/111 PLC	Correlative norms
IEC 68	Correlative tests
IEC68-2-6	Anti-vibration standards
IEC68-2-27	Anti-impact standards
IEC 1175	Design of signals and connections
IEC 801	Electro-magnetic radiation and anti-surge-interference
IEC 870	Communication protocol
IEC1000-4-2	ESD immunity test
IEC1000-4-3	RF radiation electromagnetic field interference-resistant test
IEC1000-4-4	First Transient/Burst Immunity test
IEC1800-3	Standards of EMC conduction and radiated interference
EN50082-2	General standards of industrial environment
IEEE519	Recommended practices and requirements for harmonic control in electrical system

89/336EC	CE Mark
NFPA 70	State Electrical Appliance Code
NFPA 77	Recommended anti-electrostatic methods
OCMA NWGIREV2	Noise Level Norms
ISO/IEC 11801	International electrical wiring
NEMA	American National Electrical Manufacture Association
GB 12326	Quality of electric energy supply - Admissible voltage fluctuation and flicker
GB/T 14549	Quality of electric energy supply - Harmonics in public supply network
GB 1094.1~1094.5	Power transformers
GB 6450	Dry-type power transformers
GB/T 10228	Specification and technical requirements for dry-type power transformers
GB 17211	Loading guide for dry-type power transformers
GB 311.1	Insulation co-ordination for high voltage transmission and distribution equipment
DL/T 620	Overvoltage protection and insulation coordination for AC electrical installations
GB/T 3859.1	Semiconductor convertors - Specification of basic requirements
GB/T 3859.2	Semiconductor convertors Application guide
GB/T 3859.2	Semiconductor convertors - Transformers and reactors
JB4276	Technical specifications for the packing of power convertor
GB/T	General specifications for packing of mechanical and electrical product
GB/T4064-1983	General guide for designing of electrical equipment to satisfy safety requirements
GB4028-1993	Degrees of protection provided by enclosures (IP code) and other relevant standards currently used

Chapter 2 Product Overview

2.1 Technical features

CHH Series high voltage variable frequency speed control systems are the voltage-source variable frequency speed control systems of a new generation featuring direct output of high voltage designed and manufactured by our company, implementing a perfect high voltage waveform output via the cascade of multi-level H-Bridge power units, and can directly drag the high voltage asynchronous motors without the need of boosting, and without the necessity of additional installation of any wave filter; the harmonic index complies with the most strict requirements of IEC (International Electrotechnical Commission) and GB (national standard) on grid harmonic.

CHH Series high voltage variable frequency speed control systems are applicable to three-phase current motors under standard high voltage (3kV, 6kV, 10kV), providing the following features:

- 1 Small content of input harmonic
CHH Series high voltage variable frequency speed control systems adopt trans-phase multiple rectifying technology on the power supply side; the harmonic on the grid side has little pollution and high power index, meeting the requirement of GB 14549—93 standard and IEEE std 519-1992 power quality standard on the harmonic distortion of voltage and current, and will not produce any harmonic interference to the other electrical equipment on the same grid.
- 2 Low output harmonic
CHH Series high voltage variable frequency speed control systems adopt the trans-phase multiple WDM technology on the output side, with very little output harmonic, and can adapt to various kinds of motors without the necessity of output filter equipment. Since the output voltage has low distortion and good sine degree of waveforms; the motor has low running noise, small torque pulsation and low productivity of heat.
- 3 High power factor
CHH Series high voltage variable frequency speed control systems are of the constant voltage source type, and can maintain high power factors in the full speed range, with the full load power factor of over 0.95, thereby reducing the issues of low utilization rate of the users' power transformer equipment and the power factor compensation on the user end caused by the low power factors.
- 4 Strong voltage adaptability
The input voltage has strong adaptability, allowing the fluctuating of grid-side voltage between 10%~10%. AVR function is provided to automatically adjust the output voltage according to the fluctuation of the bus voltage.
- 5 Supporting smooth rebooting after power recovery
While running, after the instantaneous power interruption of the grid and the recovery of the running conditions of the re-power-up system, if corresponding function codes are configured, then the system can be rebooted automatically after power-up. If the start-up mode is set to Rotation speed tracking Start-up, then the high voltage variable frequency speed control systems can automatically detect the rotation speed of the motors in 2.0 seconds, implementing no-impact reboot and recovering the operation to the configured state, avoiding the impact caused by the interference of electricity and ensuring the continuous operation reliability for the running of motor, thereby avoiding the loss caused by unnecessary shut-downs.
- 6 High reliance and convenient maintenance
The IGBT power module of CHH Series high voltage variable frequency speed control systems has the relatively large design margin of voltage and current; the triggering and overcurrent protection of the IGBT module uses the specialized driver module circuit, providing very high reliability.
CHH Series high voltage variable frequency speed control systems use optical fiber for the transmission of control signals, the electrical cabinets and PCBs of all functions are provided with reliable electromagnetic shielding features.
CHH Series high voltage variable frequency speed control systems adopt the modular design of "Power electronic building blocks" type for implementing the perfect structural process design, the unit-components of the same sizes are designed for universality; if any failure occurs, they can be replaced with simple tools within a few minutes, very conveniently and easily.
- 7 Alarm and failure protection functions
CHH Series variable frequency speed control system provide abundant features of alarming and protections, wherein over 11 kinds of failure messages related to the power units are already provided, all of which can be examined using the function codes in PD group.
If any failure occurs, the variable frequency speed control system can automatically record the information of the running environment of the last 3 failures, and the touch screen can record more.
- 8 Power unit bypass features:
When any failure occurs to a certain power unit of the variable frequency speed control system, the power unit can be bypassed through the bypass function, and the frequency inverter shall be derated for further running. Users can choose manual bypassing or automatic bypassing of the unit by manipulating the function codes.
- 9 Soft boot, with no surge current
CHH Series high voltage variable frequency speed control systems have the Soft boot capability to which no other system can compare. The start-up time shall be configured by the user. The internal function of over-current stall acceleration was also provided for suppressing the impact current produced at the start-up of the motor, ensuring the safe running of the motor and lengthening its service life, and to enable the rapid start-up of the grids and motors with no impact. This feature can also effectively avoid the breaking of electric squirrel cage bar in the motor and other failures of motors.

-
- 10 Reducing motor abrasion, saving maintenance costs
Blower, pumps and other loads use CHH Series high voltage variable frequency speed control systems for adjusting the rotating speed of the motor to adjust the output, which not only fulfills the objective of energy saving, but also significantly reduces the mechanical abrasion of the motor and its loads, saving maintenance costs for the users.
 - 11 Abundant user terminal interfaces
Standard CHH Series high voltage variable frequency speed control systems shall be equipped with abundant I/O ports: 3-channel analog inputs, 4-channel analog outputs, 16-channel digital inputs, 8-channel relay outputs, 1-channel high-speed pulse input and 1-channel high-speed pulse output. All I/O ports are programmable, which facilitates the users to use these ports to build up their own application system, and also guarantees the system has good extensibility.
 - 12 Abundant human-computer interface features
The human-machine interaction of CHH Series high voltage variable frequency speed control systems adopt the dual configuration of touch screens and digital keyboards, providing abundant functions of setting, display and operations and friendly human-machine interface. Users can conveniently understand the running state information of the system via the interfaces, and implement the control to the high voltage variable frequency speed control systems according to the requirement of process control.

2.2 Brief introduction of features

1. Frequency settings

Supporting multiple ways for specifying the running frequency, such as:

- 1) Specifying by keyboard
- 2) Specifying by communication (the touch screen uses this scheme)
- 3) Specifying by analog signal inputs
- 4) Specifying by high-speed pulse
- 5) Specifying by adjusting the PID control: automatically adjusting the frequencies through the comparison of PID specifying and feedback. This is particularly convenient when applied in constant pressure water supply systems.
- 6) Multi-stage speed specifying: multiple frequency bands and the acceleration/deceleration time can all be specified in the variable frequency speed control system. These frequency bands can be switched flexibly by the selecting through the terminals.
- 7) Also, for the flexibility of the control of running frequencies, CHH Series frequency inverters support 2 frequency sources, either of which, or the combination of the sum, difference and maximum values of which can be selected to be used as the actual running frequency.

Users can not only use the frequencies to control frequencies, but are also allowed to flexibly perform fine-tunings of increasing or decreasing to the running frequency by pressing the up/down buttons or manipulating the digital terminals.

For the settings related to running frequency, please refer to the descriptions of the function codes in P0 Group.

2. Acceleration/Deceleration time

CHH Series high voltage variable frequency speed control systems support 4 groups of acceleration/deceleration time. Users can choose the current acceleration/deceleration time by various combinations of the multi-functional terminals.

3. Running control methods

There are three different ways of starting up, meeting the application requirements on different occasions.

- 1) Direct start-up;
- 2) DC braking first, and then start (as for the fan-type loads, the inversion phenomenon exists; first ensure the rotating speed of the motor to be zero by the DC braking, then start the motor, in order to avoid the rush current being generated while starting up);
- 3) Rotation speed tracking start-up: the variable frequency speed control system will firstly examine the current rotating speed of the motor, and then directly start up based on it.

2 Ways of stopping:

- 1) Deceleration stop,
- 2) Free stop.

Supporting the selections of 3 different start-stop control command channels, including:

- 1) Keyboard control
- 2) Terminal control

3) Communication control.

The settings of the start-up and shut-down of the variable frequency speed control system shall refer to the descriptions of the relevant function codes in P1 Group; for the settings of the start-stop control command channels, please refer to the descriptions of the function codes in P0 Group.

4. AVR function:

CHH Series high voltage variable frequency speed control systems can automatically adjust the duty cycle of the output PWM signals according to the fluctuation of the bus voltage, thereby reducing the impact of the fluctuation of the grid voltage on the output voltage. Users can choose whether to enable the AVR function in P0 Group.

5. Miscellaneous functions:

CHH Series variable frequency speed control systems support the settings of the inching function and the hopping frequency, the usage of these functions is as follows:

- 1) Inching function: This function is mainly used for debugging, and is capable of individually setting the inching frequency and acceleration/deceleration time.
- 2) Hopping frequency: CHH Series variable frequency speed control system can specify 2 hopping frequency points at most, which are mainly used for avoiding the resonance points in the machineries, and preventing the equipment from being damaged due to resonances.

For the information of the detailed settings, please refer to the relevant description of the function codes in Group P3.

6. Torque increase function controlled by V/F

CHH Series variable frequency speed control system provides the function of low-frequency torque increasing, which is mainly used to solve the problems of lack of magnetic flux led by the voltage loss caused by stator resistors under low-frequency. Users can specify the torque increase value and the speed range of the torque increase in the function codes in Group P4.

7. Selections of multiple V/F curves

CHH Series variable frequency speed control system provides multiple forms of V/F curves (e.g. multi-points V/F curves, power of 1.3, power of 1.7, V/F curves to power of 2.0), with which various load requirements can be met. Users can choose the suitable V/F curves among the function parameters in Group P4.

8. The configuration of programmable user terminals

Standard CHH Series high voltage variable frequency speed control systems are equipped with abundant I/O terminals, and the terminals are all programmable, thereby guaranteeing the flexibility and extensibility of the system. For the detailed terminal functions, please refer to the detailed specifications of the function codes in Group P5 and P6.

9. Real-time monitoring of running parameters

CHH Series high voltage variable frequency speed control systems provide abundant parameter monitoring functions. In the running state, it is allowed to monitor the running frequency, given frequency, bus voltage, output voltage, output current, running speed, output power, output torque, PID specifying, PID feedback, terminal state, analog input value and time.

In the stopping state, it is allowed to monitor the given frequency, bus voltage, terminal state, analog input value and the current stage of the multi-stage speed.

Users can select the monitoring object to be displayed using the function codes, and can also examine the relevant parameters with the touch screen. The monitoring objects are viewed by the keyboard via the relevant function codes in Group P7.

10. PID control

PID control function can realize the closed-loop application similar to the constant water supply; it provides flexible settings of PID parameters to meet the requirements of the users on different occasions. For the details, please refer to the detailed specifications of the function codes in Group P9.

11. Multi-stage speed control

For the systems requiring frequent speed changes, CHH Series variable frequency speed control system can provide the running modes of multi-stage speed. Users can flexibly choose the speed stage currently used via the terminals. For the detailed settings of multi-stage speed, please refer to the specifications of the function codes in Group PA.

12. Failure protection functions

CHH Series variable frequency speed control systems provide abundant functions for protection; some functions can be flexibly configured through the parameters of the function codes, such as: over-voltage stall, over-current stall, loss-of-phase detections, etc. For the details, please refer to the detailed specifications of the function codes in Group Pb.

The parameters in Group PD can also be configured to shield the failure information of certain power units.

The information of the running environment of the variable frequency speed control system at the times of recent 3 failures are recorded in the parameters in Group P8, in the meantime, the failure information of the corresponding power units shall be displayed in the function codes in Group PD.

CHH Series high voltage variable frequency speed control systems also support the alarming function. While alarming: system uses acousto-optic prompts without shutdown, the system will automatically reset that alarm according to the fixed period of time, users can select whether the alarming function is shielded and configure the reset interval time of alarming.

13. Modbus communication function

CHH Series variable frequency speed control systems provide the support of standard modbus communication protocols. Users can use their own systems to implement the control and settings of the frequency inverter through modbus protocols, for the detailed relevant information about modbus, please refer to the detailed description of the function codes in Group PC.

Note: The touch screen and the frequency inverter are connected by using modbus protocols; if the touch screen is used, users will not be able to use modbus communication.

2.3 Product application fields

CHH Series high voltage variable frequency speed control systems are mainly applied to blowers and pumps and on other occasions when a great amount of energy can be saved through speed control. The detailed applications are as follows:

Thermal power: draught fans, supply blowers, dust collecting fans, compressors, water supply pumps, mortar pumps, etc.

Metallurgical mining: draught fans, ventilation fans, dust collecting fans, sandpumps, descaling pumps, centrifugal feed pumps, etc.

Petrochemical: draught fans, gas compressors, injection pumps, submersible pumps, main pipe pumps, boiler water supply pumps, brine pumps, mixers, squeezers, etc.

Cement manufacturing: kiln draught fans, raw meal grinding draught fans, pressure supply blowers, main dust collecting fans, cooler dust collecting fans, cooler exhaust fans, preheating tower blowers, sorting device blowers, kiln gas blowers, etc.

Water supply and sewage treatment: sewage pumps, clear water pumps, mixed flow pumps, oxygen delivery blowers, etc.

Others: Drive mechanical devices, wind turbines, wind tunnels, etc.

2.4 System composition and principle of work

CHH Series high voltage variable frequency speed control systems adopt power unit series connecting technology, which not only solves the problem of device withstand voltage, but also solves the problem of loop current, the trans-phase overlapping of inter-level output voltage greatly improves the harmonic performance of the system output voltage and decreases the du/dt of the output voltage, lowering the input side harmonics through current multiple technology, and reducing the harmonic pollution to the grids,

The main control part of CHH Series high voltage variable frequency speed control systems use Digital Signal Processor (DSP) as the control core, supplemented by SLSI programmable logic devices (FPGA), analog input (AI), analog output (AO), digital input (SI), relay output (RO) units.

The human-machine interfaces are composed of digital keyboards and touch screens.

The control signals of the main control part and the unit control part are transmitted through optical fiber, effectively avoiding electromagnetic interference and guaranteeing the reliability of the transmission of the system control signals.

2.4.1 System composition

The overall structure of a high voltage variable frequency speed control system of CHH Series is composed of trans-phase transformer cabinets, power unit cabinets and control cabinets, manual switching cabinets and automatic switching cabinets can also be equipped according to the user's requirements while in actual use.

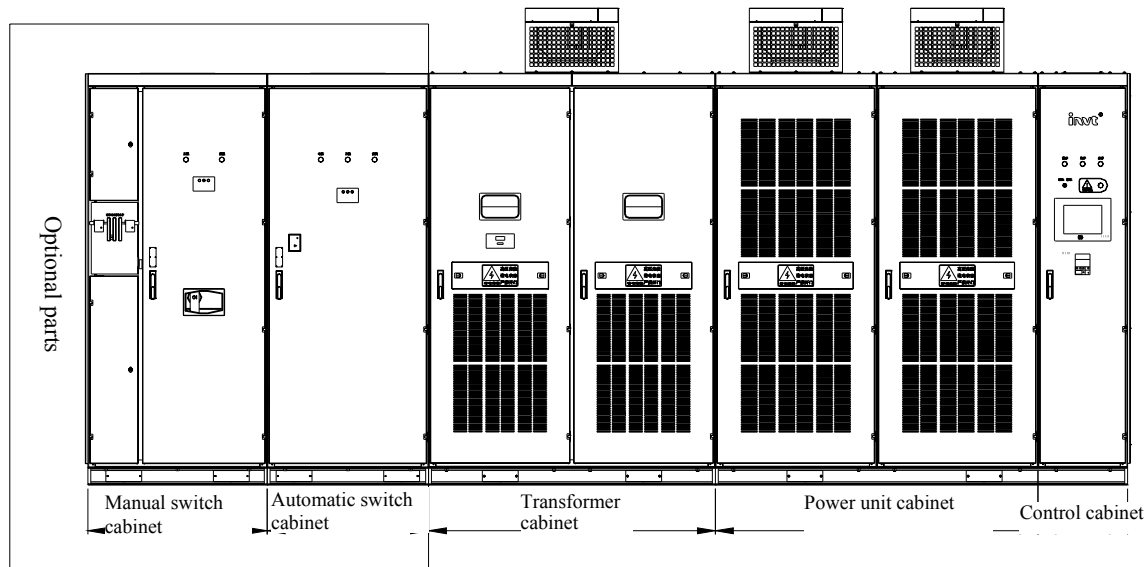

Figure 1 Outline schematic drawing of the frequency inverter

1. Trans-phase transformer cabinet

The cabinet is equipped with a trans-phase transformer on the inside, the trans-phase transformer adopts the dry-type structure, with the insulation level of Level-H; it also adopts the connection method of trans-phase prolonged edge delta, reducing the grid-side harmonics of the high voltage variable frequency speed control system. The basis of the trans-phase transformer is connected to the load-bearing framework of the cabinet body through screw bolts.

The input of the trans-phase transformer cabinet is 3-phase high voltage (through the switch cabinet). The output of the trans-phase transformer cabinet is 3-phase low voltage signals forming certain electrical angle between each other after the shape alteration of the prolonged edge delta, each of the signals shall be separately connected to the input side of the power unit of each phase.

The trans-phase transformer cabinet can monitor the temperature of the phases of the trans-phase transformer in real time, and provide the functions of overheating alarm and failure protection. The default configuration of the system is that when the temperature of the trans-phase transformer is over 130°C, the system will prompt an alarm message but will not stop; when the temperature is over 150°C, the system will start the over-temperature failure protection and freely stops.

2. Power unit cabinet

The power unit cabinet is used for placing power units; the main control cabinet uses fiber communication to control the actions of the power units. Every power unit is pushed in through the front door of the power unit cabinet and fixed on the power unit cabinet with screws (fixed through the FRP on the rear or under the rear). The parts of output voltage and current detections shall also be placed into the power unit cabinet.

The input of the power unit cabinet is the output of the trans-phase transformer; the output signal from the power unit on each phase shall be connected in series one after another to establish a 3-phase voltage output to be connected to the switch cabinet, in order to control the operation of the motor.

The Input 3-phase electricity of the power unit shall be wired through the backdoor of the power unit cabinet; the output of the 3-phase power unit shall be separately connected using copper bars, connecting the connecting terminal on the side close to the trans-phase transformer cabinet in to the switch cabinet (or lead-in cabinet) through cables; connecting the starting points of the 3 phases on the side close to the main control cabinet together with copper bars to establish the midpoint of a star-shaped connection.

The power unit cabinet is used for installing and placing high-voltage power units, the power unit uses an H-bridge structure, the output side is directly connected in a series, composing the high voltage output of the high voltage frequency inverter. The input of the power unit is 3-phase rectifying input, which corresponds to the output of the trans-phase transformer. The control panel interacts with the power unit through the signals of optical fibers, the main transmission signal is the drive signal, failure and alarm signals and other control signals of power units.

The output current detection Hall and the rotating speed tracking circuit board are installed in the interior of the power unit cabinet.

3. Control cabinet

The control cabinet is the brain of the entire variable frequency speed control system. It uses a separate UPS for power supply. The UPS has 2 channels of power input (main and standby power supply), when the main power supply is invalid, the system will automatically switch to the standby power supply. When the UPS is broken but one channel of the main standby power supply is still valid, the electricity for the control cabinet will be provided by the main standby power supply. When the UPS or one channel of the main standby power supply fails, the system will prompt an alarm, which ensures that the system can be used in the worst power supply environment.

The input signals of the control cabinet are: the contactor state signal of the switch cabinet (according to the configuration), I/O voltage, current detection signals, the feedback signal of each power unit and the users operation via the human-machine interface, etc.

The output signals of the control cabinet are: the control signal of the power units (optical fiber), the control signal of the fans and the contactor control signals of the switch cabinet.

Touch screens, keyboards and other human-machine interfaces area all installed on the control cabinet.

The programmable terminals open to users for using are also installed on the control cabinet.

4. Switch cabinet

CHH100 Series of the high voltage frequency inverter provide standard switch cabinets for users to select. The switch cabinets mainly realize the functions below:

User I/O connection terminals; power frequency/variable frequency conversion function; relevant affiliated electrical protection measures; in the meantime, the insulation of the trans-phase transformer with the distribution system is also provided.

The input of the switch cabinet is the users' 3-phase high voltage distribution; it shall be connected to the trans-phase transformer via KM1 (QS1).

The output of the switch cabinet is the 3-phase frequency conversion output of the power unit cabinet; it will be directly connected to the motor via KM2 (QS2).

The switch cabinet also provides the power frequency bypass contactor KM3, once any failure occurs to the frequency inverter, users can directly switch the motor to the state of power frequency via the vacuum contactor KM3 to effectively guarantee the consistent running of the system. Inside the switch cabinet, KM2 (QS1) and KM3 (QS2) implement the interlocking through logic.

The voltage and current transformers are installed inside the switch cabinet to provide the actual input voltage and current information to the control cabinet.

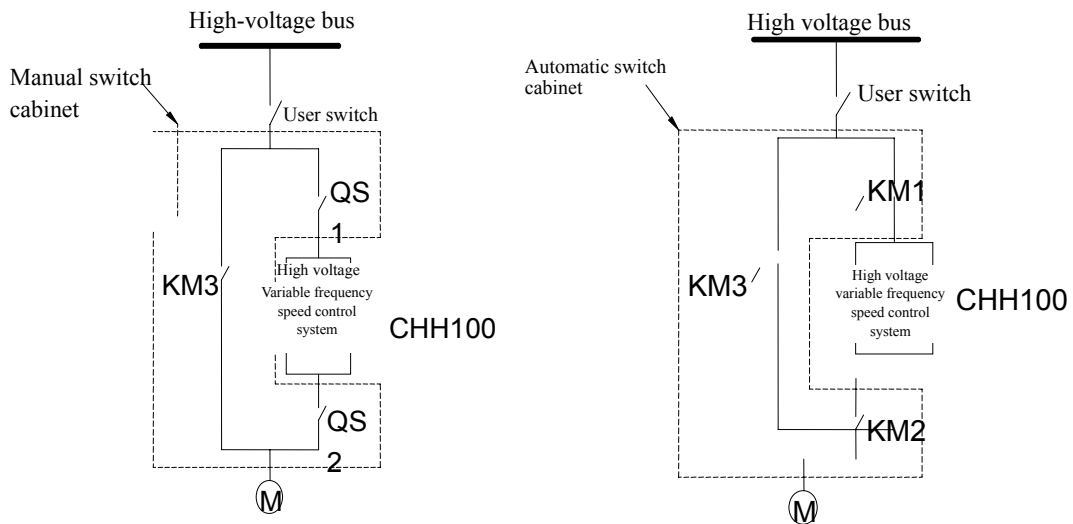

Figure 2 Schematic drawings of Manual and automatic switch cabinets

As shown in the drawing above, this is a typical configuration of switch cabinets, wherein the QS1 and QS2 are the manual knife switches; the KM1, KM2 and KM3 are the vacuum circuit breakers. Users can choose to use manual switch cabinet or automatic switch cabinet as needed.

2.5 Public technical parameters, specifications and models

2.5.1 Model description

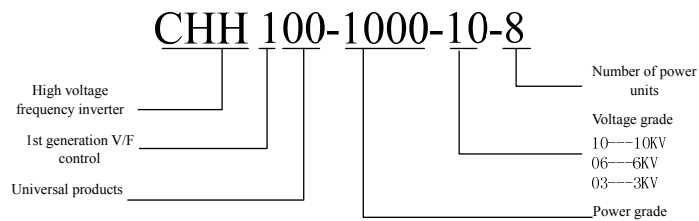

Figure 3 Product model definition of CHH Series frequency inverters

2.5.2 Descriptions of data plate mo

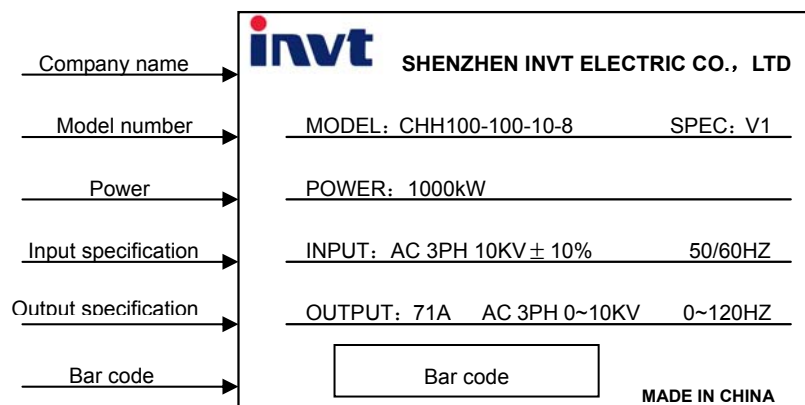

Figure 4 Data plate of the high voltage frequency inverter

2.5.3 General parameters of the system

Items	Technical specifications
Rated capacity	236KVA~9000KVA
Rated power	185KW~7100KW
Input voltage	3/6/10KV±10%
Input frequency	50/60Hz±10%
Number of power units on each phase	3 or 4 of 3KV; 5 or 6 of 6KV; 8 or 9 of 10KV
Input power factor	>97% (under rated load)
System efficiency	>96% (under rated load)
Output frequency	0~120HZ (continuously adjustable)
Output voltage	0~rated input voltage
Overload capacity	120% rated current protection for 60s; 150% rated current protection for 1s
Control interface	touch screen 、 keyboard
Acceleration/deceleration time	0.1~3600S can be set up.
Control characteristics	V/F control, multiple V/F curves are available to be selected
High/low voltage insulation method	High and low voltages are insulated by optical fiber
Communication	RS485 physical ports, supporting modbus standard communication protocols
Switch input	16-channel digital inputs
Switch output	8-channel relay outputs
Analog input	3-channel analog input terminals AI1, AI2, AI3 AI1, AI2: 0~10V/0~20mA, AI3: -10V~10V
Analog output	4-channel analog output AO1~AO4, output range: AO1, AO2: 0~10V, AO3, AO4: 0~10V/0~20mA
High-speed pulse input	Range: 0~50KHz
High-speed pulse output	Range: 0~50KHz
Noise level	< 75dB
Harmonics	Meeting the requirements of national standard GB 14549-93 and IEEE 519-1992 power quality standards.
Protection functions	Overvoltage protection, undervoltage protection, overcurrent, overtemperature, overspeed, external faults, etc.
Protection level	IP20
Cooling method	Forced-air cooling
Using environment	Indoors, altitude of below 1000m (the higher altitude shall be used after derating with additional correction factor), no corrosive, explosive gas or dust, no direct sunlight, etc.
Ambient temperature	-10℃~+40℃ (>40℃, additional installation of forced-air cooling unit)
Ambient humidity	5~95%, no gel
Vibration	5.9m/s ² below 0.5g

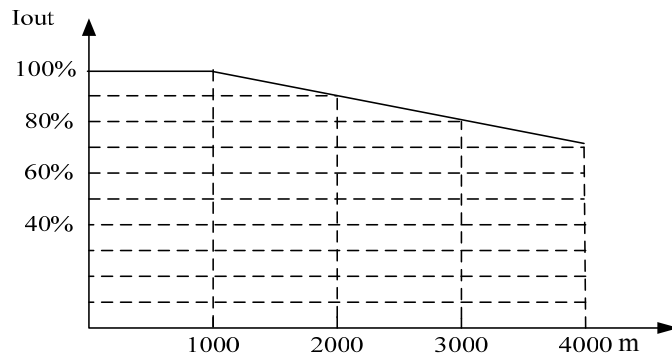

Figure 5 Relation chart of the altitude and derating index

2.6 System profile and size parameters

2.6.1 System profile

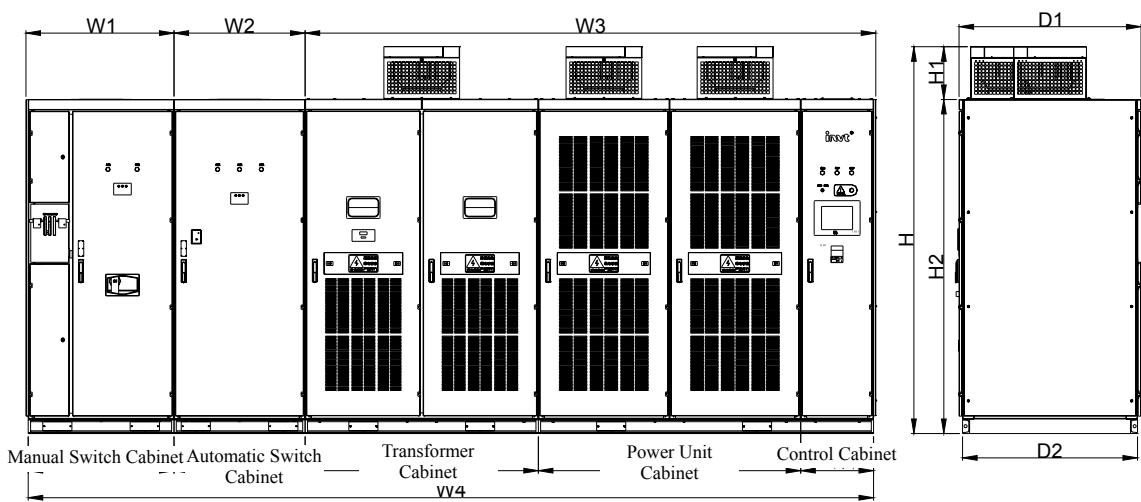

Figure 6 Outline structural chart of the high voltage frequency inverter

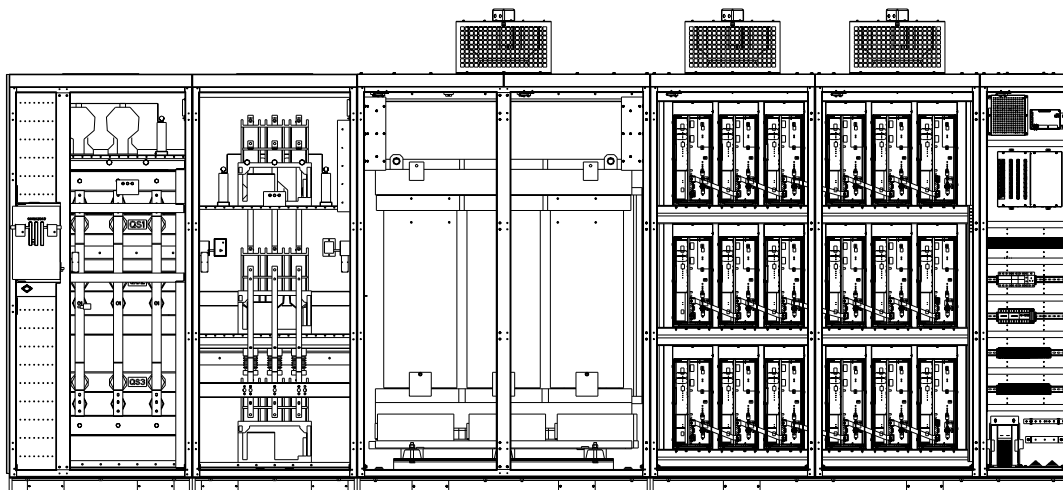

Figure 7 Inner schematic drawing of the high voltage frequency inverter

2.6.2 System size parameters

Table 1 of the Basic parameters of CHH100 Series of frequency inverter (3kV)

Serial NO.	Frequency inverter model	Rated voltage (kV)	Rated capacity (kVA)	Rated current (A)	Motor power (kW)	Outline dimension of frequency inverters W2×H×D(mm)	Size of Manual bypass cabinet W1(mm)	Size of automatic bypass cabinet W2(mm)
1	CHH100-0200-03	3	250	48	200	4100×2400×1200	900	
2	CHH100-0250-03	3	315	60	250	4350×2400×1200	900	
3	CHH100-0315-03	3	400	75	315	4350×2400×1200	900	
4	CHH100-0400-03	3	500	95	400	4350×2400×1200	900	
5	CHH100-0500-03	3	600	116	500	4350×2400×1200	900	
6	CHH100-0630-03	3	750	150	630	4350×2400×1200	900	
7	CHH100-0800-03	3	980	185	800	4950×2700×1200	900	
8	CHH100-0900-03	3	1100	210	900	4950×2700×1200	900	
9	CHH100-1000-03	3	1250	230	1000	4950×2700×1200	900	
10	CHH100-1250-03	3	1500	300	1250	4950×2400×1200	900	
11	CHH100-1400-03	3	1700	330	1400	4950×2700×1200	900	
12	CHH100-1600-03	3	1900	370	1600	4950×2700×1200	900	
13	CHH100-1800-03	3	2000	420	1800	6250×2700×1500	900	
14	CHH100-2000-03	3	2700	460	2000	6250×2700×1500	900	
15	CHH100-2240-03	3	3000	520	2240	6250×2700×1500	900	
16	CHH100-2500-03	3	3300	600	2500	7200×2700×1500	900	
17	CHH100-2800-03	3	3700	650	2800	7200×2700×1500	900	

Table of the Basic parameters of CHH100 Series of frequency inverter (6kV)

Serial NO.	Frequency inverter model	Rated voltage (kV)	Rated capacity (kVA)	Rated current (A)	Motor power (kW)	Outline dimension of frequency inverters W2×H×D(mm)	Size of Manual bypass cabinet W1(mm)	Size of automatic bypass cabinet W2(mm)
1	CHH100-185-06	6	236	23	185	3900×2700×1200	1000	900
2	CHH100-0200-06	6	255	25	200	3900×2700×1200	1000	900
3	CHH100-0220-06	6	280	27	220	3900×2700×1200	1000	900
4	CHH100-0250-06	6	315	30	250	3900×2700×1200	1000	900
5	CHH100-0280-06	6	350	33	280	4300×2700×1200	1000	900
6	CHH100-0315-06	6	400	37	315	4300×2700×1200	1000	900
7	CHH100-0355-06	6	440	42	355	4300×2700×1200	1000	900
8	CHH100-0400-06	6	500	48	400	4300×2700×1200	1000	900
9	CHH100-0450-06	6	560	54	450	4300×2700×1200	1000	900
10	CHH100-0500-06	6	600	60	500	4300×2700×1200	1000	900
11	CHH100-0560-06	6	690	67	560	4300×2700×1200	1000	900
12	CHH100-0630-06	6	750	75	630	4300×2700×1200	1000	900
13	CHH100-0710-06	6	880	84	710	4300×2700×1200	1000	900
14	CHH100-0800-06	6	980	95	800	4300×2700×1200	1000	900
15	CHH100-0900-06	6	1100	106	900	5100×2700×1200	1000	900
16	CHH100-1000-06	6	1250	118	1000	5100×2700×1200	1000	900
17	CHH100-1120-06	6	1370	132	1120	5100×2700×1200	1000	900
18	CHH100-1250-06	6	1500	146	1250	5100×2700×1200	1000	900
19	CHH100-1400-06	6	1700	164	1400	5100×2700×1200	1000	900
20	CHH100-1600-06	6	1900	185	1600	5100×2700×1200	1000	900
21	CHH100-1800-06	6	2000	220	1800	5100×2700×1200	1000	900
22	CHH100-2000-06	6	2400	229	2000	5100×2700×1200	1000	900

23	CHH100-2240-06	6	2700	261	2240	7700×2700×1500	1000	900
24	CHH100-2500-06	6	3000	281	2500	7700×2700×1500	1000	900
25	CHH100-2800-06	6	3300	324	2800	7700×2700×1500	1000	900
26	CHH100-3150-06	6	3700	363	3150	7700×2700×1500	1000	900
27	CHH100-3550-06	6	4500	428	3550	7700×2700×1500	1000	900
28	CHH100-4000-06	6	5000	482	4000	7700×2700×1500	1000	900
29	CHH100-4500-06	6	5600	542	4500			
30	CHH100-5000-06	6	6200	595	5000			

Table of the basic parameters of CHH100 Series of frequency inverters (10kV)

Serial NO.	Frequency inverter model	Rated voltage (kV)	Rated capacity (kVA)	Rated current (A)	Motor power (kW)	Outline dimension of frequency inverters W2×H×D(mm)	Size of bypass cabinet W1(mm)	Size of bypass cabinet W2(mm)
1	CHH100-0220-10	10	295	17	220	5200×2700×1200	1000	900
2	CHH100-0250-10	10	330	19	250	5200×2700×1200	1000	900
3	CHH100-0280-10	10	360	21	280	5200×2700×1200	1000	900
4	CHH100-0315-10	10	400	24	315	5200×2700×1200	1000	900
5	CHH100-0355-10	10	450	27	355	5200×2700×1200	1000	900
6	CHH100-0400-10	10	500	30	400	5200×2700×1200	1000	900
7	CHH100-0450-10	10	570	33	450	5200×2700×1200	1000	900
8	CHH100-0500-10	10	630	37	500	5500×2700×1200	1000	900
9	CHH100-0560-10	10	710	41	560	5500×2700×1200	1000	900
10	CHH100-0630-10	10	800	46	630	5500×2700×1200	1000	900
11	CHH100-0710-10	10	870	51	710	5500×2700×1200	1000	900
12	CHH100-0800-10	10	980	57	800	5500×2700×1200	1000	900
13	CHH100-0900-10	10	1100	64	900	5500×2700×1200	1000	900

14	CHH100-1000-10	10	1200	71	1000	5500×2700×1200	1000	900
15	CHH100-1120-10	10	1370	79	1120	5500×2700×1200	1000	900
16	CHH100-1250-10	10	1500	88	1250	5500×2700×1200	1000	900
17	CHH100-1400-10	10	1700	98	1400	5500×2700×1200	1000	900
18	CHH100-1600-10	10	1900	112	1600	6500×2700×1500	1000	900
19	CHH100-1800-10	10	2200	127	1800	6500×2700×1500	1000	900
20	CHH100-2000-10	10	2400	141	2000	6500×2700×1500	1000	900
21	CHH100-2240-10	10	2700	157	2240	6500×2700×1500	1000	900
22	CHH100-2500-10	10	3000	175	2500	6500×2700×1500	1000	900
23	CHH100-2800-10	10	3600	205	2800	6500×2700×1500	1000	900
24	CHH100-3150-10	10	4000	230	3150	6500×2700×1500	1000	900
25	CHH100-3550-10	10	4500	260	3550	6500×2700×1500	1000	900
26	CHH100-4000-10	10	5000	290	4000	11700×2700×1500	1000	900
27	CHH100-4500-10	10	5600	326	4500	11700×2700×1500	1000	900
28	CHH100-5000-10	10	6300	362	5000	11700×2700×1500	1000	900
29	CHH100-5600-10	10	7000	405	5600	11700×2700×1500	1000	900
30	CHH100-6300-10	10	8000	456	6300	11700×2700×1500	1000	900
31	CHH100-7100-10	10	9000	512	7100	11700×2700×1500	1000	900

〔Remarks〕 : The outline dimensions of the high voltage variable frequency speed control systems listed in the table above are the standard sizes. The outline dimensions of the high voltage variable frequency speed control systems may differ to the outline dimension of the high voltage variable frequency speed control systems listed in the table due to the requirements of the actual users.

Chapter 3 System transportation, storage and waste disposal

The functional unit electrical cabinets of CHH Series high voltage variable frequency speed control systems are assembled, tested and packaged as a whole for outgoing from factories. During the transportation, the cabinet bodies must be transported as a whole. To improve the reliability of the variable frequency speed control system, and avoid the high voltage variable frequency speed control system being damaged during the transportation, this chapter identifies the basic requirements for transportation and storage. The environmental requirements of transportation and storage specified in detail in this chapter must all be strictly abided by. Any violation of the relevant requirement in this chapter will influence the service life of the high voltage variable frequency speed control system.

3.1 The transportation of high voltage variable frequency speed control systems

The outer packaging of CHH Series high voltage variable frequency speed control systems can endure the external impact from the sea, land or air transportation, but appropriate protection measures must be taken to avoid the pollution of water immersing and dust. Also, during the process of sea, air and land transportation, the impact of damage caused by mechanical external shocks and rough handling must be avoided. To realize correct shipping, disassembling and storage, please note that all relevant precautions and indication and instruction tags are marked on the packing boxes. We recommend entrusting logistic companies with a good reputation and credit with the lifting and transportation of high voltage variable frequency speed control systems.

Transportation: CHH Series high voltage variable frequency speed control systems can be transported using cars, trains, airplanes, ships and any other vehicles. During the transportation, the products must be handled with care. Exposure to rain and sunlight are both strictly forbidden, no severe vibration, impact and upend is allowed.

Hoisting: The power unit cabinets, control cabinets and switch cabinets can all be handled via flying rings. Due to the large weight of trans-phase transformers, while hoisting, it is required to disassemble the 2 shoulders of the cabinet tops and then complete the hoisting via the flying rings of trans-phase transformers.

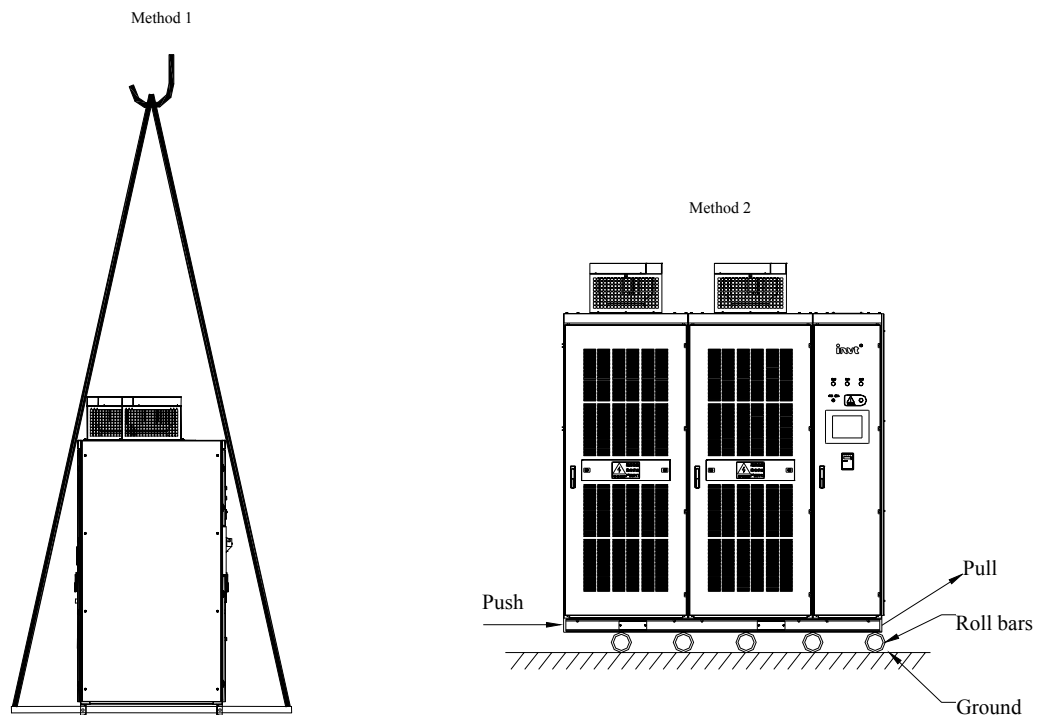

Figure 8 Hoisting schematic drawing of high voltage frequency inverters

During the handling of variable frequency speed control systems, it is allowed to do the job referring to the 2 methods shown in the figures above. Method 1 is to put the fixed wire ropes through the drill holes on the bottom of the frequency inverter cabinets; the latter method is to carry out the handling using rolling bars.

3.2 Arrival acceptance check

After receiving the high voltage variable frequency speed control equipment that you ordered, if there is anything wrong with the products you ordered or they don't comply with the specifications that you ordered, please contact the agent from whom you order the equipment or contact the nearest office of our company.

- ① Check the data tags of the high voltage variable frequency speed control systems and confirm the models and specifications of the equipment you ordered.
- ② Check whether any damage has occurred during the handling and transportation on the appearance, such as

damage to the cabinet body appearance, any deformation to the door and sideboards and any falling off of the inner devices, etc.

- ③ Open the cabinet door and check the situation inside the cabinet, and check for the occurrence of the loosening of the control cables, water immersion, as well as missing or damaged devices.
- ④ Contrasting to the supply lists, check if there's any shortage and other issues of the equipment that you ordered, to prevent the omission of parts.

〔Note〕 Since the configuration requirements of the users to the high voltage variable frequency speed control systems are different, the configurations of the high voltage variable frequency speed control systems of same capabilities will also differ.

3.3 Storage and conditions

Inappropriate methods of custody of power electronic equipment will affect the service lives of the equipment, or even result in the failure of the equipment.

Table – Custody environment conditions

Items	Specifications	
Storage temperature	-40~+70℃, the change of air temperature of less than 1℃/Min	Don't put in the places where condensation and freezing occurs due to acute changes of temperature.
Relative humidity	5~95%	
Preservation environment	Not subject to direct sunlight, dust, corrosive gas, flammable gas, oil mist, vapor or water dripping.	

General requirements:

- ① Don't place it directly on the ground; place it on appropriate supporting objects.
- ② If there is any impact of humidity, appropriate desiccating agent shall be provided: each unit of desiccating agent (30g) absorbs 6g of water content. According to the packaging materials used, you will need the desiccating agent of the following amounts: Polyethylene metal film: 10 units per square meter; aluminum metal film: 8 units per square meter.
- ③ Using polyethylene materials or aluminum metal film as the protective packaging can prevent the water content from infiltrating:
Regular inspections: During the whole storage period, the inspection of the storage status and packaging status of the equipment shall be carried out once a month. Focus, in particular, on mechanical damage and the damage caused by humidity, temperature or fire hazard. If the packaging is damaged or you have found that the equipment has been damaged, you should immediately check the equipment damage situation, and store the variable frequency speed control system according to the requirements mentioned above after repairing the damaged equipment.

3.4 Storage of spare parts

After receiving CHH Series high voltage variable frequency speed control systems, you shall immediately check whether there is any damage to the spare parts, and if any damage to the spare parts is found, please report it to our company. Our company will not undertake any product quality guarantee responsibility for the damages caused by external shocks or external environment within the product quality guarantee period. Within the quality guarantee period, to keep the equipment spare parts from being damaged, please pay attention to the following items: there must be no vibration or impact at the storage place, and it is a requirement to prevent damage from moisture, frost, temperature, dust and gravels. The environmental conditions shall meet the requirements of temperature and humidity: The spare parts must be stored in a dry original packing box with no flying insects, and kept away from corrosive gas. The relative air humidity shall be 5%~95%, and the storage temperature of the spare parts shall be -5℃~+55℃. The circuit boards must be stored in anti-static packing bags with no leakage of moisture-proof agent, and must be kept away from corrosive gases that will cause damage to the circuit boards or gases containing alkali-saline or other impurities and mustn't be frozen. If you find that the humidity has surpassed the maximum allowable extent in the air, environmental protection measures such as cooling, heating, dehumidifying and other methods shall be taken to guarantee the environmental conditions for storing the spare parts.

The power unit is equipped with electrolytic capacitors on the inside, the long-term power-off of the electrolytic capacitors will lead to the deterioration of their electrical characteristics; therefore, the preservation shall be carried out in the method of electrifying once every year.

3.5 Product waste treatment

	<p>Notes</p> <p>When the product packs and the products are being discarded, they shall be treated as industrial waste, otherwise injury accidents or environmental pollution may occur.</p>
---	---

The packaging of CHH Series high voltage variable frequency speed control systems shall be designed with the minimum usage of the packing materials that have adverse effects on the environment; some of the packing materials can be recycled and reused. The treatment of the packing materials shall comply with the national standard related to environmental protection.

While discarding the devices inside the high voltage variable frequency speed control systems, the electrolytic capacitors, PCBs, electronic components and other parts need to be treated with correct methods for any part of them not to cause harm to the surroundings. These treatment methods can refer to the national legislation and regulations to the environment protection.

Chapter 4 System Installation and Wiring

The main bodies of CHH Series high voltage variable frequency speed control systems are composed of the trans-phase transformers, unit switch cabinets, main control cabinets and others. Wiring cabinets or bypass switch cabinets are also included according to the user's choice, therefore, as for different projects, the arrangement and layout of the equipment shall be determined according to the appropriate positions, with the layout and installation diagrams provided.

4.1 Installation of cabinet bodies

1. Requirement of running environment

The efficiency of CHH Series high voltage variable frequency speed control systems is over 96%, 4% of the loss will be basically converted into heat energy. Therefore, the cooling issue of the high voltage variable frequency speed control systems needs to be taken into consideration. If the installation environment of the high voltage variable frequency speed control systems is narrow and the ambient temperature is high, additional installation of forced-air cooling unit or air conditioning cooling devices is needed. We recommend adopting the exhaust air rate of larger than 1M³/S every 200KW of capacity during air cooling; and when air conditioning cooling is used, more than 4 HP of air conditioners shall be configured for every 200KW of capacity.

2. Requirements of spacing for cabinet placement

For the drawings of the cabinet dimension, outline dimension and the bottom plate installation of the variable frequency speed control system, please refer to the drawings related to engineering technical information. All cabinet bodies shall be installed according to the drawings and sufficient spacing shall be provided in the periphery, in order to guarantee the air flow, the maximum door swinging and the space required for maintenance, and also providing the channel for entering the installation basis (aisle spacing, etc.) and ensuring the space for the auxiliary equipment used for providing the transportation of the variable frequency speed control system.

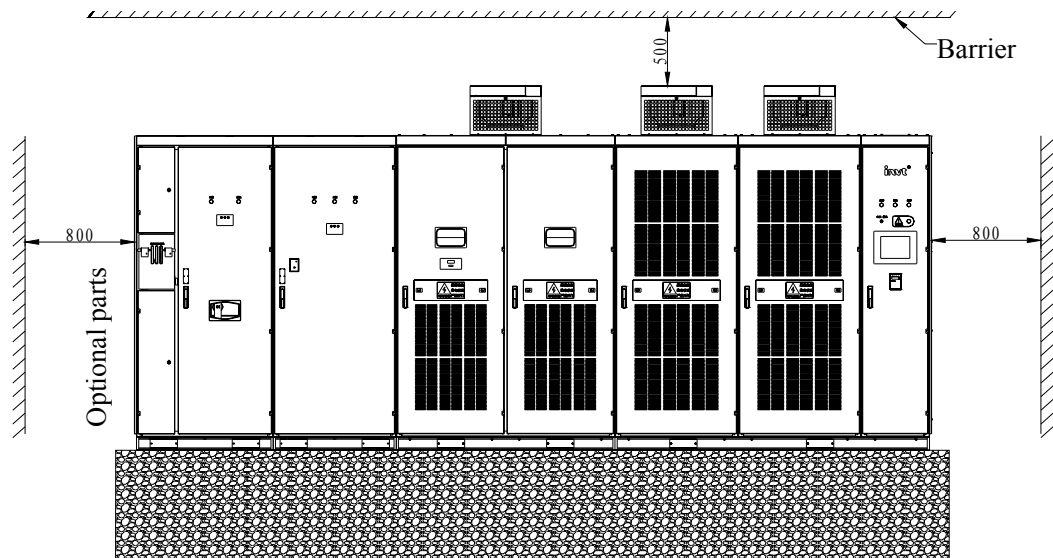

Figure 9 Schematic Drawing 1 of installation requirements of the high voltage frequency inverter (Front view)

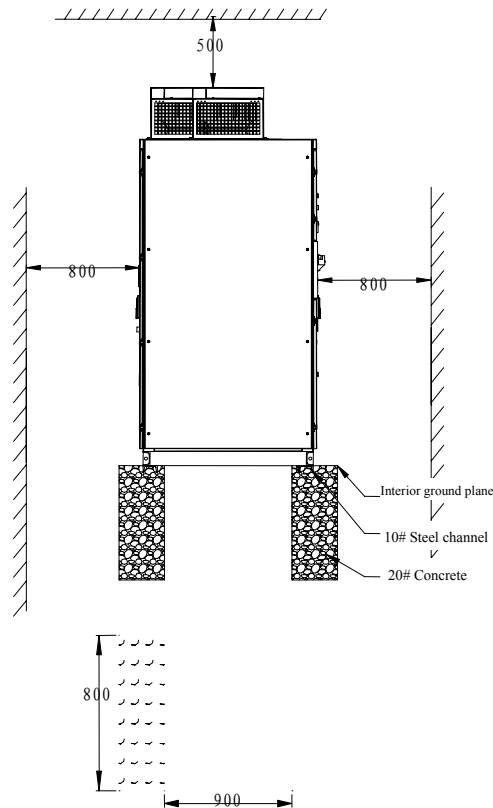

Figure 10 Schematic drawing 2 of the installation requirements of high voltage frequency inverters (Side view)

The basic requirements of the widths of the surrounding channels of the cabinet are shown in the figure above and the table below.

Minimum widths of the surrounding channels of high voltage variable frequency speed control systems		
Layout mode	Maintenance channel	Running channel
Dual-row layout	1m	2.0m
Single-row layout	1m	1.5m

The cooling air duct of the variable frequency speed control system is shown in the figure below. To guarantee sufficient cooling, it must be guaranteed that the distance between the top of the variable frequency speed control system and the roof complies with the requirement of the relevant national regulations. For further lowering ambient temperature, users can install centralized ventilation air ducts for transmitting the hot air through centrifugal blower and directly lead it to the outside through the air ducts.

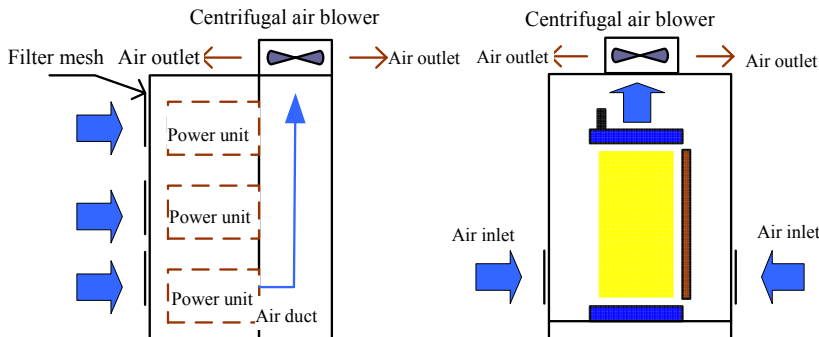

Figure 11 Schematic drawing of the cooling air ducts of the high voltage frequency inverter

3. The requirement of the foundation installation of the variable frequency speed control system

The cabinet bodies of CHH Series high voltage variable frequency speed control systems must be vertically

installed onto the concrete casting foundation framework made of flat steel channels, the overall roughness of the surface shall be less than 5mm. the foundation must be made of non-combustible materials, and have smooth and abrasion-free surface, and shall be moisture-proof and able to bear the weight of the variable frequency speed control system. The cable ducts must be made of non-combustible material and have smooth and abrasion-free surface, and shall be moisture-proof and dust-proof, providing the measures for preventing the animals from entering.

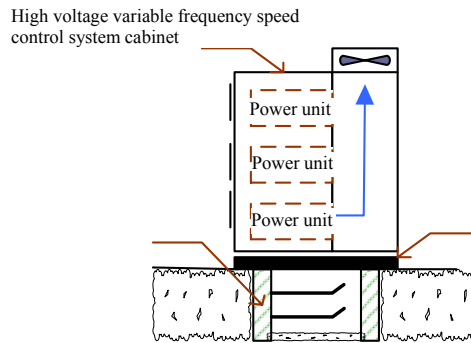

Figure 12 Schematic drawing of the basic requirements of installation of the high voltage frequency inverter

4. Installation of cabinet bodies

The high voltage variable frequency speed control system is composed of more than 3 cabinet bodies (this depends on the power size and the layout mode). According to the requirement, a single cabinet or multiple cabinets can be placed upon the foundation steel channels vertically using traveling crane or forklift. The trans-phase transformer cabinet must be installed separately.

The cabinet bodies shall be assembled, connected, positioned and aligned, then shall be directly welded onto foundation steel channels, the connecting wires inside the cabinets and the ones between the cabinets shall be installed under the guidance of the professional from our company.

In some cases, the trans-phase transformers and power units shall be separately packaged for transportation, and shall be installed into the trans-phase transformer cabinets and power unit cabinets under the guidance of the professional from our company after arriving at the destination.

Notes

⚠ It shall be installed onto the non-combustible structure made of basic steel channels, otherwise it may cause fire.

◇ Ensure that various kinds of fibers, paper scraps, sawdust, metal fragments and other foreign matters don't enter into the cabinet or adhere to the radiators; otherwise it may cause accidents or fire.

The following installation guide is applicable to the general installations in industrial environment. If the application in special environment and occasions is required, please make inquiry to our company for detailed installation procedures.

1. Before the machinery installation, please be sure to meet all environmental conditions described in the previous points.
2. Examine the basic level with level instruments. The allowable maximum overall roughness is less than 5mm. If the ground surface is not flat, then it must be smoothed.
3. Move to the installation position. Please refer to the requirement of Chapter 3, Handling of high voltage variable frequency speed control systems to do the handling and moving.
4. Open all cabinet doors, and carefully inspect possible transportation damage of the variable frequency speed control system and the attached equipment thereof. If any part is damaged or missing, please immediately contact the technical service department of our company and the corresponding transportation company. Please note the opening methods of cabinet doors.
5. Check whether the cabinet door can be fully opened or closed; if not, the cabinet body needs to be adjusted. Examine the position-restraint locks on the doors: after the power is turned on, aside from the doors of the main control cabinets, no other front doors and back doors can be opened. The illegal opening of cabinet doors will trigger the alarm.
6. Perform the fine adjustment of the cabinet bodies, and fix the adjacent cabinet bodies tightly with binding bolts.
7. Under the guidance of the professionals of our company, connect the wiring inside the cabinet bodies, install and fix the power units.

Note: Please pay attention to the methods for opening the cabinet door; forced opening of cabinet door is forbidden, otherwise the equipment will be damaged.

Table of basic installation check items of plate cabinet

Working procedure	Inspection items	Quality standard	Inspection methods and apparatus
Basic installation	Basic steel non-straightness	<1 mm/m	Guy wire inspection
	Error levelness	(or <5 mm/full length)	Track level bar inspection
	Basic centerline error	±5mm	Inspect with ruler
	Plate cabinet basis and ground fixing mode	≤10mm	Inspect with leveler or communication pipes
	Elevation difference	Consistent to the ground elevation	Inspect with leveler or communication pipes
	Basic layout	According to the design	Inspect with contrast to the drawings
	Number of basic steel grounding points	>2 points	Inspect by observation

	Grounding connection	Firm, with good conduction	Inspect by wrenching and guiding
--	----------------------	----------------------------	----------------------------------

4.2 Installation of the high voltage parts

1. Standard requirement of high voltage distributions

Firstly, the high voltage power supply needs to pass through the main circuit breaker and then shall be connected to CHH Series high voltage variable frequency speed control systems; it is allowed to close the main circuit breaker only after receiving the high voltage closing permit signal.

The high voltage power supply of the main circuit breaker shall be directly connected into the input terminal of the switch cabinets (or incoming cabinets) of the variable frequency speed control system without the need of passing through the input reactor.

The variable frequency output of high voltage variable frequency speed control systems is directly connected to high voltage motors via the output terminals of the switch cabinets (or incoming cabinets).



Notes

- ✧ The input and output terminals cannot be connected incorrectly, otherwise the high voltage variable frequency speed control systems will be damaged.

2. Wiring of the switch cabinets of high voltage variable frequency speed control systems

Terminal ID	Terminal name	Remarks	
Input	L1	Main circuit power supply input, 1 st phase sequence	Connect to 3-phase high voltage AC power supply, 1 st phase sequence
	L2	Main circuit power supply input, 2 nd phase sequence	Connect to 3-phase high voltage AC power supply, 2 nd phase sequence
	L3	Main circuit power supply input, 3 rd phase sequence	Connect to 3-phase high voltage AC power supply, 3 rd phase sequence
Output	U	High voltage frequency inverter output, 1 st phase sequence	Connect to 3-phase AC high voltage motor, 1 st phase sequence
	V	High voltage frequency inverter output, 2 nd phase sequence	Connect to 3-phase AC high voltage motor, 2 nd phase sequence
	W	High voltage frequency inverter output, 3 rd phase sequence	Connect to 3-phase AC high voltage motor, 3 rd phase sequence

【Remarks】 The phase sequence of U, V and W output of the high voltage variable frequency speed control systems may be inconsistent with the phase sequence of power supply L1, L2 and L3; on the occasions when the power frequency power supply bypass is needed, please check the I/O phase sequences of the high voltage variable frequency speed control systems, and make the phase sequence of both consistent, otherwise the system may not work normally.

3. Requirements of equipment and cables

◆ Main circuit breaker

The main circuit breaker may be the vacuum or gas insulation circuit breaker. It must not only meet the requirement of the supply voltage and current, but also the requirement of the rated voltage and current of the trans-phase transformer on the primary side. Its basic electrical characteristic also has to be able to bear the closing impulse current of the transformer and the failure current caused by the secondary side short circuit of the transformer within 100ms, and won't cause trip.

◆ Protective equipment

The high voltage switch on the power side of CHH Series high voltage variable frequency speed control systems shall be configured with reasonable protection, the setting of the protection definite value shall be carried out in reference to the following principles:

When the winding on the primary side or the incoming cables on the primary side of the trans-phase transformer fails, the switch must conduct immediate trip. The setting value of the protection current must be sure to dodge the excitation surge current for switching-in no-load without trip (this can be set as 8 to 10 times of the rated current of the trans-phase transformer).

The fault protection of the secondary side of trans-phase transformers adopts the method of delayed trip. When short circuit failure occurs to the winding on the secondary side of the trans-phase transformer, the cables connecting the secondary side of the trans-phase transformer with system units, and the unit input bridge rectifier, the incoming switch can be flipped open. With short delay of protection, the time settings can be adjusted and can be set to ensure the trans-phase transformer of no trip will occur during the period of excitation surge current. The movement current setting value can be set as twice the rated current of the rectifying transformer, so as to ensure that when failure occurs on the secondary side of the rectifying transformer, trip will be performed within 500ms.

Overload protection (optional) is a long-time overload protection with the feature of inverse time limit, and can protect the long-time overload of transformers and cables.

If the system is a part of a high-voltage large-capacity motor reconstruction project, the vertical protection of the high voltage motor protection shall quit during the variable frequency operation, and shall be put in during the power frequency bypass, the switching function needs to be realized in the technical schemes.

◆ Primary side cables of transformers

No special requirement to the cables between the primary side of the transformer and the circuit breaker is proposed. The rated voltage shall be consistent with the circuit voltage on the primary side. The rated current of cables shall comply with the protection setting value of the transformer. The lower capacitance value shall be designed according to the maximum expected ambient temperature, cooling factors and the other factors required by local electrical regulations, and the installation shall be completed according to the standard for medium-voltage devices.

◆ **Cables with outputs to the motors**

No special requirement of the Cables from CHH Series high voltage variable frequency speed control systems to the motors is proposed. We recommend the length to be no longer than 1000 meters, the case that the field cable length is larger than 1 kilometer shall be proposed in the order.

The rated voltage of the cables is consistent with the corresponding motor models; the rated current of the cables shall comply with the motor models and the permit overload current for motor protection. The capacitance lowering of cables shall refer to the highest ambient temperature, cooling factors and the other factors required by local electrical regulations. The installation shall be completed according to the standard for high-voltage devices.

Since the waveforms of the output voltage and current of CHH Series high voltage variable frequency speed control systems are close to standard sine waves, no special shielding is required for the cables. Therefore there is no need to take special measures for the common mode current.

4. High voltage cabling

The cabling of main power supply and the motor must comply with national standards, please refer to the specifications and recommendation of the cable manufacturers.

- ◆ We recommend using separately shielded armored 3-phase cables; if single-phase cables are used, the combination of 3-phase cables is required to ensure the EMC characteristics.
- ◆ If the area of the shielding layer of the cables is less than 50% of the area of a 1-phase cross section, then an additional grounding line must be provided to prevent the shielding layer of the cables from overheating.
- ◆ The cable terminations must comply with the requirement of the cable manufacturers, the cables connectors must be installed at the terminations.
- ◆ The grounding of the grounding terminals of the corresponding cables must comply with the national standard of electrical installation.

5. Equipment grounding

Users shall be sure to provide good grounding wires with grounding resistance of less than 4 ohms, copper bars shall be used for connecting the cabinet bodies of CHH Series high voltage variable frequency speed control systems, the connecting wires between the grounding points of whole sets of devices and the grounding points of grids shall use the copper-core cables with the cross-section of no less than 50 mm². The detection of grounding system is required before being put into operation, in order to guarantee the equipment and personal safety.

6. Precautions

- ◆ All connections of the electrical installations of high voltage variable frequency speed control systems must be installed by experienced electric engineers according to the national standards related to electrical installations.
- ◆ All high-voltage connectors must receive insulation treatment to ensure good insulation.
- ◆ The high voltage connecting positions must be kept clean and meet the requirement of the corresponding cleanliness.
- ◆ All work must be carried out while the main power supply and the auxiliary power supplies are all disconnected.
- ◆ Connect the main incoming cables and the output motor cables correctly, otherwise the equipment of the whole variable frequency speed control system will be seriously damaged when the power is turned on.
- ◆ The phase sequence of output cables is related to the rotating direction of the motor, please connect the U, V and W according to the requirement of load turning directions, and perform tests before formally putting into operation.

<p>Danger</p> 	<ol style="list-style-type: none"> 1. Before cabling, please confirm that the input power supply has been cut off. There is the risk of electric shock and fire. 2. Please call electric engineering professionals to perform the cabling operation. There is the risk of electric shock and fire. 3. Please be sure to make reliable grounding of the cabinet bodies. There is the risk of electric shock and fire. 4. Please be sure to test the normal functioning of the power/variable frequency switch and the emergency breaking buttons before power is turned on. There is risk of injuries. (Users shall take the responsibility of cabling) 5. Please don't touch the output terminals directly, the output terminals of the variable frequency speed control system must not be connected to the casing, there mustn't be short connections between output terminals. There is the risk of electric shock and causing short circuit.
---	--

<p>Danger</p> 	<ol style="list-style-type: none"> 1. Please check whether the AC main circuit power supply is consistent with the rated voltage of the variable frequency speed control system, otherwise there will be risks of injury and fire hazard. 2. The voltage resistance test shall be performed according the manual; otherwise it will cause the damage to the semi-conductor components and others. 3. Please use the screw driver of designated torque to tighten the terminals, otherwise there will be the risk of fire. 4. Please don't connect the input power supply line to the output U, V and W terminals. Putting voltage on the output terminals will cause the inner damage of the
---	--



Notes

- All high voltage connectors must receive insulation treatment to ensure good insulation. The high voltage connecting positions must be kept clean and meet the requirement of the corresponding cleanliness.
- The electrical insulation distance of the high voltage positions must comply with the requirement of electrical safe distance to avoid any short circuit caused by the electric discharge.

The electric insulation detection test to the input end of the system shall be performed after the short-connecting and grounding of the iron core of the trans-phase transformer and all secondary outgoings; **while performing the electric insulation detection test to the output end of the system, no unit output is allowed to be connected into the output cables; otherwise the power units will be damaged.**
- After the completion of all connections, the detection of electric insulation properties shall be carried out to the input end of the system, the experimental voltage shall use the reference value as follows: for 6kV system, it shall be 25kV, for 10kV system, it shall be 35kV. During the field hand-over test, the actual insulation test voltage shall choose 75% of the value mentioned above. If the air humidity is apparently too large on the spot, or there's the situation that the humidity is relatively large for a long time in the long-term storage environment before the installation, commissioning and operation of the system, if the equipment are found to be damped before putting into operation, then further voltage withstand test must not be carried out, in order to avoid the equipment being damaged. The voltage withstand test shall be performed after using non-fire heating source for drying.
- The indicators at the high voltage positions must be clear and eye-catching to avoid errors.
- Installation of large-current positions: to enable the variable frequency speed control system to meet the technical properties, great attention must be paid to the installation of large-current positions (All incoming terminals and output terminals with the current flow of larger than 10A shall be considered large current terminals). The key points are:
 - ◆ Terminals shall be made of the materials with excellent conductive properties, such as oxygen-free copper terminals, silver-plating or tin-plating fasteners and other connecting materials.
 - ◆ All terminals shall be carefully cleaned with ethanol before connecting.
 - ◆ Connections of all connectors shall be very reliable, the fasteners shall be tightened with wrenches, the important connectors shall be wrenched tight reliably with torque wrenches to ensure the contact resistance is less than 2 milliohms.
 - ◆ The fasteners of all large-current connecting positions shall include spring rings, which shall be pressed flat after fastening.
 - ◆ The large-current connecting wires shall use appropriate current density to avoid the heating and the consequent impact on equipment use.

4.3 Wiring of user terminals

1. General introduction of user terminals

CHH Series high voltage variable frequency speed control systems provide the terminals of 16 channels of digital inputs, 8 channels of relay outputs, 3 channels of analog inputs, 4 channels of analog outputs, 1 channel of high-pulse input and 1 channel of high-pulse output. All user terminals are programmable and can be specified using the function codes.

CHH Series high voltage variable frequency speed control systems connect all terminals the users used onto the terminal blocks. Please carry out the wiring from the terminal blocks while using.

1) Description of the terminal ports the users used

Classification	Terminal markings	Terminal functions	Technical specifications
Upper communication	485+	485 communication positive pole	Standard 485 Physical interface, supporting standard MODBUS communication protocols
	485-	485 communication negative pole	
Digital input	S1、S2、S3、S4、S5、S6、S7、S8、S9、S10、S11、S12、S13、S14、S15、S16	Switch input terminals	<ol style="list-style-type: none"> 1. Forming the optical coupler isolation input with COM 2. The input voltage can only be the 24V provided by the system 3. The suspension of terminals will be regarded as disconnected 4. Input impedance: 3.3KΩ

	HDI	High pulse input terminals	<ol style="list-style-type: none"> Forming the optical coupler isolation input with COM The input voltage can only be the 24V provided by the system The suspension of terminals will be regarded as disconnected Input impedance: 1.1KΩ
24V Power supply	+24V	24V power supply provided by the system, for the use of digital input and high-pulse input.	<ol style="list-style-type: none"> Maximum output current 150mA
	COM	24V Powers supply grounding	
10V Power supply	+10V	+10V power supply provided by the system, for the use of analog input	<ol style="list-style-type: none"> Maximum output capability 20mA
	GND	+10V Powers supply grounding	
Analog input	AI1、AI2	Analog input terminals. Support the inputs of voltage and current.	<ol style="list-style-type: none"> Forming a loop connection with GND We recommend using the +10V provided by the frequency inverter as the input voltage. For voltage input, voltage range 0~+10V; for current input, current range 0~20mA, 20mA current responds to +5V. Input impedance: 20KΩ (voltage) /250Ω (current).
	AI3	Analog input terminals. Only support voltage input, the input range permits negative voltage	<ol style="list-style-type: none"> Forming a loop connection with GND We recommend using the +10V provided by the frequency inverter as the input voltage. Voltage input range is -10V~+10V. Impedance of voltage input is 20KΩ.
Analog output	AO1、AO2	Analog output terminals, Only support voltage output	<ol style="list-style-type: none"> Outputting the voltage corresponding to the GND terminals. Output voltage range 0~+10V Maximum output loop current range 0~2mA, minimum input impedance of external circuit 5KΩ.
	AO3、AO4	Analog output terminals, Support the inputs of voltage and current.	<ol style="list-style-type: none"> Outputting the voltage and current corresponding to the GND terminals. While voltage output: Output voltage range 0~+10V, output permit impedance\geq5KΩ While current output: Output current range 0~20mA, output permit impedance 100~500Ω
Relay output	R01、R02、R03、R04、R05、R06、R07、R08	Relay output terminals	<ol style="list-style-type: none"> Contact point definition: A Public terminal, B Normally closed, C Normally open. Contact point capacity: AC250V/1A, DC30V/1A.

2) Wiring diagram of user terminals

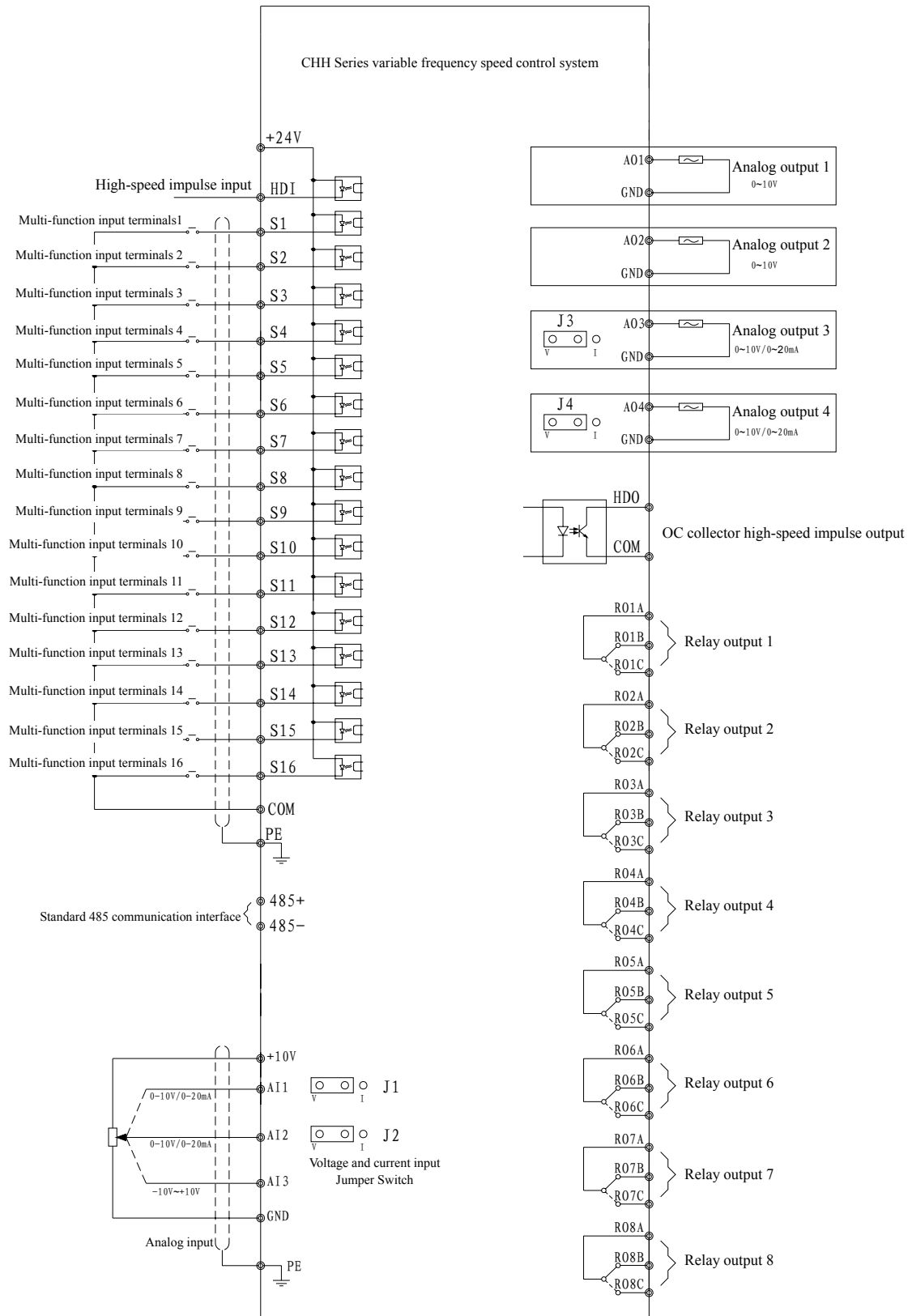

Figure 13 Wiring diagram of user terminals of the high voltage frequency inverter

2. Precautions



Note the grounding check

□ Usually, the user control wires shall not use the wires with reinforced insulation. If wire insulators are damaged due to certain reasons, then the intrusion of the high voltage into the control circuit is possible. This is not permitted for European Low Voltage Directive. If this situation occurs, electric shock or equipment damage may result.

□ If shielding cables are used, the cable shielding layer can only be grounding at a single termination of each cable.

□ To ensure the normal work of the variable frequency speed control system, it must be guaranteed that work of various signal lines is normal without being affected by various electromagnetic interference. Therefore, during the installation of user control wires, the correct installation of these signal lines must be focused on in the following aspects.

◆ Separate wiring of the signal wires and power cord, especially the large-current high voltage wires, must be ensured to avoid electromagnetic interference. The control cables shall not be wired parallel to the power cables. If this situation is inevitable, the distance between the control cables and main cables must be kept as a minimum 30cm. The control cables and power cables shall be cross-wired perpendicularly.

◆ Separate wiring of digital signal lines and analog signal lines is required to avoid mutual interference.

◆ If the signal lines and power cords must be wired in the same place, then the shielding measures shall be taken to the signal lines, so as to reduce the interference produced by power cords to the signal lines as much as possible.

◆ Avoid the parallel wiring of signal lines and power cords so as not to produce mutual interference.

◆ The grounding of signal lines must be connected to shielding wires reliably; the shielding layer must also be reliably grounded at one single termination.

◆ If necessary, the signal lines can be connected to the external through the threading of metal conductive casing pipes. In this way, various interference signals can be reliably isolated to ensure the normal operation of the variable frequency speed control system.

◆ For reducing the interference and attenuation of the control signals, the connection length of the control signal lines shall be limited within 50cm.



Note the wiring inspection

After the wiring is completed, please be sure to check

- ◇ Whether there is anything wrong with the wiring.
- ◇ Whether there is any residue of the screws and connectors inside the equipment.
- ◇ Whether there is any loosening of the screws.
- ◇ Whether the bare conductors of the terminal parts are connected to other terminals.

Chapter 5 System debugging and running

The debugging of CHH Series high voltage variable frequency speed control systems must be carried out under the guidance of the professionals of our company. The function testing, debugging and parameter settings must be carried out strictly according to the relevant regulations and the instruction manual of the high voltage frequency inverter of our company.

During debugging, users must provide at least 2 professional electric technicians as the running staff required by the debugging, and the running staff must comply with the following conditions:

- Familiar with the high voltage electrical equipment and the corresponding safety standards.
- Familiar with the Users' load driving process.
- Authorized to operate high voltage equipment (Power circuit breakers and other high voltage transmission switches, etc.).
- Authorized to operate transmission equipment.



Note

- ◇ Ensure the high voltage variable frequency speed control systems are correctly wired, and all electrical cabinet doors are closed before connecting to the power supply. The cabinet doors cannot be opened after the power is turned on.
- ◇ Correctly setting the function parameters of the high voltage variable frequency speed control system.
- ◇ While booting, the system is designed to ensure personal and equipment safety.
- ◇ When the power of the variable frequency speed control system is turned on, even if it is in the state of shutdown, the terminals are still electrified and must not be touched.
- ◇ The running and stopping of the high voltage variable frequency speed control systems can not be operated by the methods of connecting or disconnecting the main circuit.

5.1 Items of detection and confirmation before debug running

1. Appearance: The coating layer on the surface shall be uniform with no bubble or falling off, and there shall be no trace of scratching or flash, the assembly of the whole machine shall be tight with no existence of undesirable phenomenon.

2. Silk print: The silk printing on the chassis casing is correct, the characters and symbols are clear and correct, with no burrs, segment missing or other undesirable phenomenon in the fonts, and the appearance shall be clean and bright.

3. Functional short wiring: complies with the process files, the J4 of control panel shall adopt the method of short connection of 485 pins.

4. Whether there are any miscellaneous objects inside the chassis, and whether the machine numbers on the data tags on the chassis are consistent with the machine numbers in Product File.

5. The shielding layer of the I/O shielding wires on the voltage detection board coming out from the power unit cabinets near the main control cabinets shall be grounded on one termination; the I/O shielding wires on the speed tracking board shall be grounded on one termination.

6. Check whether the connection wires between the trans-phase transformer and power units are firm and whether the connection wire sequence is consistent.

7. The optical fiber jump wires between the optical fiber drive board on the control panel and the power units are correctly connected.

8. Whether the line sequence of all control lines are consistent with the diagrams.

5.2 Tests of Control cabinet power on and after power-on

5.2.1 Main control cabinet power on

1. Ensure that L1, L2 and L3 are disconnected to high voltage inputs.

2. Start the UPS; when the keyboard on the running panel of the frequency inverter displays “-CHH-” and is flashing, the 7 LED lights shall all be turned on. After 2 seconds, all LED lights shall go out except the ones that correspond to Hz.

3. The interface of the touch screen shall display the initialization interface, and finally pop up the Login button. After pressing the login button of the person in charge, the system will enter the main interface and prompt that the DC bus lacks voltage.

4. Observe deviation of the temperature displayed on the trans-phase transformer cabinet and the actual ambient temperature, and if it is less than 1°C, it will indicate that the deviation is normal.

5.2.2 Testing whether the work of KM1 (QS1), KM2 (QS2) and KM3 are normal

1. Ensure that L1, L2 and L3 are disconnected from the high voltage power supply

2. In the touch screen interface----» Function Settings, click the Settings button within the Running Mode box on the interface of Function Settings; Enter the Power/Variable Frequency Switch interface.
3. Click Variable Frequency in the interface
4. You will then hear the sound of the contactor twice, and the 2 indicator lights on the leftmost of the switch cabinet will be turned on.
5. Measure the on-off of KM1, KM2 and KM3 with a multimeter, now KM1 and KM2 are on, and KM3 is off.
6. Click “Cut off high voltage” in the interface.
7. You will then hear one beep of the contactor, the indicator light of switch cabinet will go out.
8. Measure the on-off of KM1, KM2, KM3 with a multimeter, now KM1, KM2 and KM3 are all off.
9. Click “Power frequency” in the interface.
10. You will then hear one beep of the contactor, the indicator lights on the leftmost of the switch cabinet are turned on
11. Measure the on-off of KM1, KM2 and KM3 with a multimeter, now KM1 and KM2 are off, and KM3 is on.
12. UPS power-down, reboot the UPS after the system is all power down.
13. Reboot the UPS, then, after switching the power on, you will hear a beep of the contactor sound, the indicator lights of the switch cabinet will go out.
14. Click “Variable frequency” in the interface, and wait until the 2 indicator lights on the leftmost of the switch cabinet are both turned on.
15. Press the emergency breaking switch on the control cabinet, and you will hear one beep of the contactor.
16. Measure the on-off of KM1, KM2 and KM3 with a multimeter, now KM1 and KM2 are off, and KM3 is on.
17. Turn the emergency breaking knob to the normal position.
18. Measure the on-off of KM1, KM2 and KM3 with a multimeter, now KM1 and KM2 are on, and KM3 is off.

5.2.3 Testing whether the power alarm is normal

1. Main control cabinet is power on, turn the switch of the input power supply 1(Q1) open, the system will trigger the alarm of Power supply 1.
2. Close the switch of the input power supply 1 (Q1), the system alarm disappears.
3. Open the switch of the input power supply 2 (Q2), the system will trigger the alarm of Power supply 2.
4. Close the switch of the input power supply 2 (Q2), the system alarm disappears.
5. Close the UPS, the system will trigger the alarm of UPS.
6. Boot the UPS, the system alarm disappears.

5.2.4 Test insulation resistance

1. Short connect L1, L2, L3, U, V and W.
2. Main control cabinet is power on, switch the system to the Power frequency work state via the touch screen.
3. Measure the inner resistance between the short-connected L1, L2, L3, U, V, W and the cabinet body; the resistance shall be over 20MΩ.
4. Measure the insulation resistance between each power unit casing and the cabinet body with a withstanding voltage tester; the resistance shall be over 20MΩ.

5.2.5 Motor parameter settings

1. Complete the parameter settings of the function codes of P2.00~P2.05 according to the data plate of the motor.

5.3 Main loop power on and power-on debugging

5.3.1 Whole machine high-voltage on

1. Connect L1, L2 and L3 separately to the high voltage inputs. Make sure the U, V and W are disconnected to the motor; and the system is in the state of power-off. Close all cabinet doors.
2. Switch the system to Variable frequency state via the touch screen.
3. Connect to the high voltage according to the operation procedures (when it is the first time to connect to high voltage power supply, all staff need to stay over 3 meters away from the cabinet).
4. After over 6 seconds after power is turned on, the Ready LED (Yellow LED) is turned on.
5. Make sure that the noise of the trans-phase transformer cabinet is below 75db.

5.3.2 Correction of the unit voltage and temperature

1. Make sure that L1, L2, L3 are separately connected to the high voltage inputs. Make sure U, V and W are disconnected to the motor, and the variable frequency speed control system is working in the state of variable frequency.
2. Log in the touch screen as the person in charge, and enter the parameters in PD group.
3. Observe PD.03~PD.29, the temperature deviation displayed shall be no more than 2℃.
4. Observe PD.30~PD.56, the voltage deviation of the unit shall be no more than 50V.

5.3.3 Disconnecting the motor and no-load running

1. Keep the power-on configuration of 3.2, and connecting to a high voltage.
2. Press “**RUN**” button on the keyboard, and run at 50HZ.
3. The blower on the cabinet top starts to work, listen and check whether there’s any abnormal sound or noise when the blower starts; if no noise or abnormal sound is heard and the running is steady, then the air blower is working normally.

5.4 Test with motors

5.4.1 No-load test with motors

1. Connect L1, L2 and L3 separately to the high voltage inputs; connect U, V and W to the high voltage motor. Connect to the input, switch the frequency inverter to variable frequency.
2. Set the output frequency to 10Hz while testing with the motor, then increase the frequency to 20Hz after the motor is running steadily, then increase to the rated frequency of the motor with this method and start the motor, and run at 50HZ.
3. During the whole process, there is no abnormal sound or vibration of the motor, and the running is steady.
4. Press the Slowdown & Stop button, the output frequency of the frequency inverter has decreased. And press the Free stop command when it decreases to about 5HZ.
5. After blocking the pulse, press the Start command again, then the frequency inverter will reach the current rotating speed within 2 seconds, and steadily accelerate the motor to 50HZ.
6. No jump fault is allowed during the deceleration process.

5.4.2 Motor testing with load

1. Run the motor to 50Hz with actual load.
2. Enter Group PD, detect PD.03~PD.29, the difference between the detected temperature and the actual ambient temperature must not be more than 30°C .

Chapter 6 Operation of the variable frequency speed control system

	<ul style="list-style-type: none"> ◆ Running without complying with the guidance of Chapter 1-Safety Notes is very dangerous. ◆ Only the staff that have received training and obtained the permission of the user's organization can perform the operation to the variable frequency speed control system. ◆ The description in this chapter only takes the switch cabinet of our company as an example; the different application requirements will cause the changes of the wiring principles of the switch cabinet, please refer to the description in this chapter and make up the operation procedures according to the wiring principles of the actual bypass cabinet.
---	--

In this chapter, all normal running procedures after completing the installation and debugging of CHH Series high voltage variable frequency speed control systems are introduced in detail step by step, and all necessary operation steps are numbered, the operation must be precisely carried out strictly according to these operation steps. For the detailed operation of KM1 and KM2 switch cabinets, please refer to (the content in 2.4.1).

6.1 Description of switch cabinet

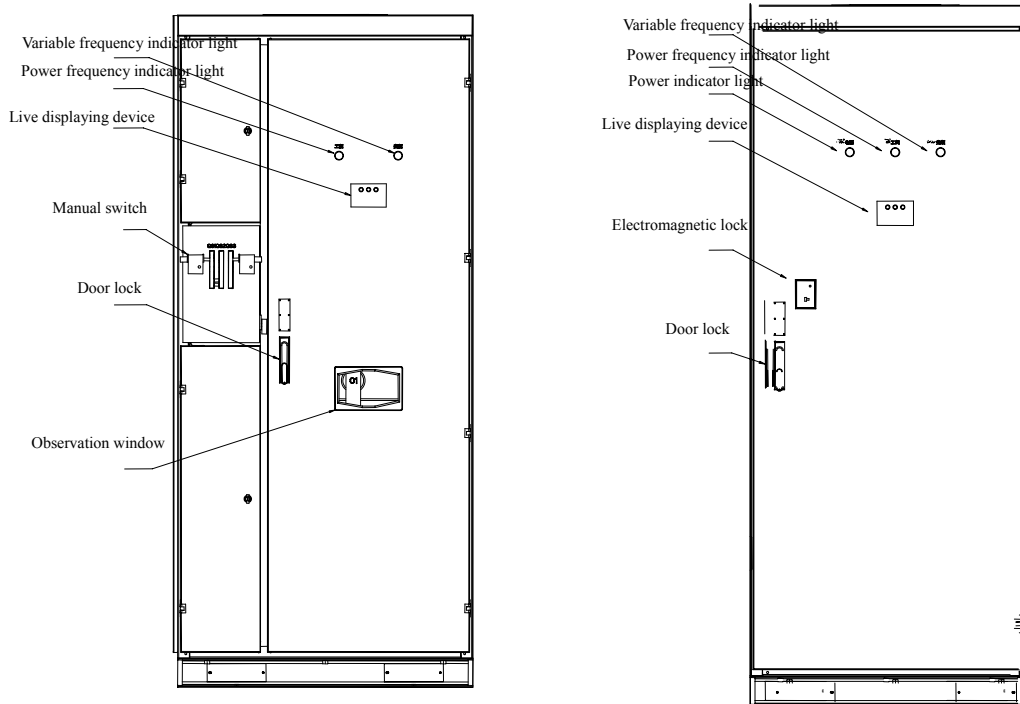

Figure 14 Outline structure schematic drawing of manual and automatic switch cabinet

As shown in the figure:

Fault indicator light and warning light: This indicator light indicates that the variable frequency speed control system is in the state of fault or warning. If any fault occurs, then the fault indicator light and warning light will be turned on, the warning light will produce a buzz sound. If any warning occurs, then the fault indicator light and warning light will light up and go out intermittently taking 2 seconds as the interval, and will buzz intermittently.

Running indicator light: This indicator light indicates whether the variable frequency speed control system is in the state of running, and if so, the indicator light will be turned on.

Ready indicator light: It indicates whether the variable frequency speed control system is in the state of ready & standby, and if the system is power up but is not running, and no fault is detected, then the indicator light is turned on.

Emergency Breaking button: when the main control panel is damaged, or other faults that can't be normally controlled occur to the system, users can directly disconnect KM1 through physical lines by pressing the emergency breaking switch, and thereby minimize the losses.

Note: After pressing the Emergency Breaking button, please turn to loose then switch the power on.

Note: When the switch cabinet is in the power frequency state, the Emergency Breaking button is invalid. If you then want to cut off the high voltage, the only applicable method is either directly cutting off the upper-level power

supply, or sending the directive of cutting off high voltage to the system.

6.2 Operation steps of variable frequency speed control system



- ◆ Even if the high voltage is cut off, you still need to wait for 30 minutes to touch the body of the variable frequency speed control system. Otherwise, electric shock accidents may occur since the DC bus of the power units is electrified.

1. Power on

- 1: Make sure that the debugging and running operations of the variable frequency speed control system has already been completed according to the instructions in Chapter 5.
- 2: Power up the main control cabinet.
- 3: Check and make sure that the settings of all parameters related to transmission system are correct. The parameters that must be examined include the parameters related to the frequency settings, the operation control modes and the V/F curves described in Section 2.2.



- ◆ The parameters that have special impact to the start-up must be carefully confirmed, in order to guarantee the safety and normal start-up of the equipment.

- 4: Confirm that the manual disconnected switch (if manual disconnected switch is provided) is in the closing state, and confirm that current KM1, KM2 and KM3 are all in the open state.
- 5: Close all doors (control cabinet can be excluded).



- ◆ If some cabinet doors are not reliably closed, the system will trigger the acousto-optic alarm, and will not be able to work normal.

- 6: Send the operation instructions of variable frequency down to the system (can be sent down via the touch screen or terminals, the sending down by terminals needs to send pulse signals to the terminals configured as “Variable frequency operation” function).
- 7: The DCS in the upper level waits for the high voltage closing permit signal to be fed back by the variable frequency speed control system, and after receiving the signal, close the high voltage switch in the upper level, then power up with high voltage.
- 8: After the power up, check whether the Ready indicator light of the control cabinet is on, or check whether the high-voltage variable frequency speed control feeds back the ready signals.

2. Start-up

- 1: Perform the power up according to the required operations of power up.
- 2: Check whether CHH System is ready and whether the Ready indicator light of the control cabinet is on, then confirm that the fault and warning indicator lights on the control cabinet are out. If any fault or warning exists, then the fault elimination can be carried out according to the warning information provided on the keyboard/touch screen, referring to the methods described in Chapter 9-Fault detection and elimination in this document.
- 3: Specify the running frequency in accordance with the designated frequency specifying mode.
- 4: Specify the running control signals according to the designated control mode.

3. Deceleration shutdown

Carry out the shutdown operation according to the control mode.

Note: Before the frequency output is not lowered down to the shut-down frequency, if starting signal is given again, the system will raise the frequency to the specified target frequency.

4. Free shutdown

After free stopping, the variable frequency speed control system stops the voltage output; the motor rotates freely and will gradually slow down under the impact of the load and friction.



- ◆ Whether the working condition allows the free shut-down of the motor needs to be fully estimated.
- ◆ During the process of free shutting down, due to the residual magnetism, voltage may still exist in the output cables.
- ◆ After shutdown, do not touch the main circuit and motor, this is because the DC voltage of the frequency inverting part still exists.

5. Power off

- 1: Execute the shutdown or free shutdown operations of the variable frequency speed control system.
- 2: Send down the power-off command to the frequency system (can be sent down via the touch screen or terminals).
- 3: If the high-voltage switch in the upper-level is also controlled by the system, the system will first break off the high voltage switch in the upper level, then break off the switch of the switch cabinet. If the high-voltage switch in the upper-level is not controlled by the system, the system will break off the switch of the switch cabinet.
- 4: If the high-voltage switch in the upper-level is not controlled by the system, then you need to manually break off the high-voltage switch in the upper-level after the switch of the switch cabinet is directly broken off by the system.



- ◆ After the AC incoming wire is disconnected, it will take at least 30 minutes for the DC voltage to drop to the safe value.
- ◆ As long as the system is still electrified, please don't get near the bypass cabinet, transformer cabinet, power unit cabinet and the circuits related to the motors

6. Fault treatment

Step 1: If the main control system is judged to be working abnormally, it is required to manually press the emergency breaking button of the control cabinet, and then the switch cabinet will immediately cut off the high voltage input.

Step 2: When any failure occurs during normal operation, after the failure occurs to the power unit, CHH Series variable frequency speed control systems can choose to directly cut off the high voltage or choose bypass running according to the settings. The system-level faults of CHH Series variable frequency speed control systems are classified as light faults and severe faults. For the light faults, free shut-down shall be performed; and for the severe faults, the high voltage shall be directly cut off.

Step 3: Shut down the variable frequency speed control system

Step 4: Power off

Step 5: 30 minutes after cutting off the power, the faults that occurred shall be treated according to the fault treatment methods in Chapter 9.



- ◆ If Emergency Breaking button is pressed, it is required to first turn the emergency breaking knob to the Reset position after the fault is excluded, so as to perform the Power/Variable frequency switching normally.

7. Maintenance of the variable frequency speed control system

Step 1: Execute power-off operation of the variable frequency speed control system.

Step 2: If switch cabinets are chosen, and the load still needs to run, you shall first switch the frequency inverter to the Power frequency running state via the switch cabinet.



- ◆ Due to the live-running of the switch cabinet, the incoming wires still carry high voltage, so the switch cabinet must not be opened during the maintaining process.

Step 3: Open the transformer cabinet body, connect the grounding wires on the input side of the transformer, and take good measures of safety grounding.

Step 4: Perform the maintenance of the transformer cabinets and power cabinets.

Step 5: After the maintenance, remove the safety grounding wires on the input side of the transformer.

Step 6: If the system is not running with Power frequency bypass, and you want to recover the running of the variable frequency speed control system, you shall switch to the variable frequency running according to the procedures of power-up and booting-up. If the system is running with Power frequency bypass, and you want to recover the running of the variable frequency speed control system, you shall first set the boot mode to Speed tracking Boot up, then boot and run using the method of switching the Power and Variable frequency switch to the mode of Variable frequency.

Chapter 7 Human-machine interface

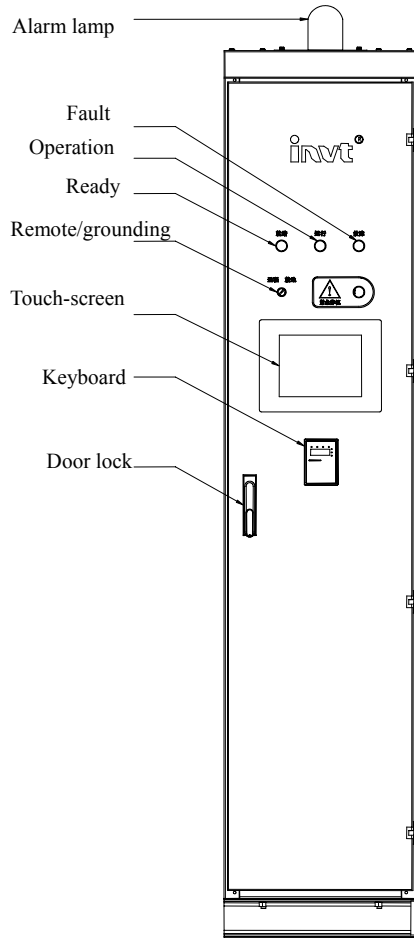

Figure 16 Schematic drawing of the human-machine interface of the high voltage frequency inverter

7.1 Keyboard

7.1.1 The outline of keyboard and the position in the system

All default configurations of each high voltage variable frequency speed control system of CHH Series include a keyboard. The keyboard is connected to the high voltage variable frequency speed control system via the keyboard wires. All operations of controls, parameter settings, status query and fault reset shall be performed through the keyboard. The position of the keyboard in the variable frequency speed control system and the meanings of the buttons are as follows:

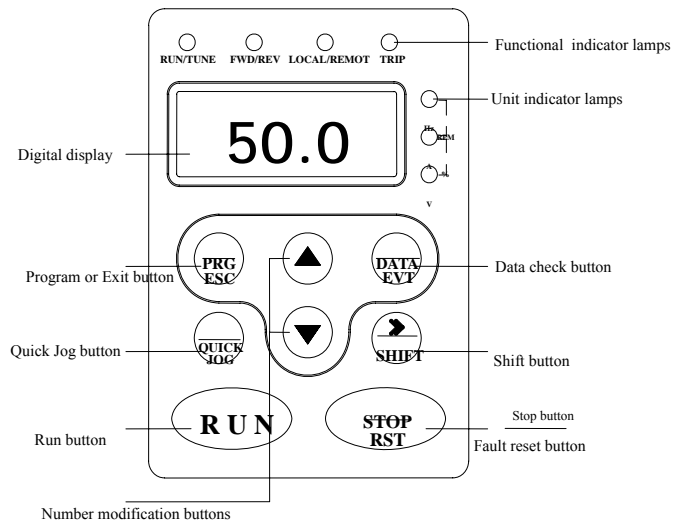







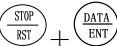

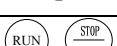

Figure 17 Schematic drawing of the operation panel

7.1.2 General introduction of the functions of the buttons on the keyboard

1) Preliminary introduction of buttons

Button symbols	Name	Function descriptions
	Program button	Enter and exit the running interface, or return from a menu at a certain level to the menu of the upper level.
	OK button	Within the running interface, enter the menu at the next level; if the menu is on the 3 rd level at this time, then the pressing of this button will confirm the numerical value shown in the menu of this level.
	UP Increment button	Increment of data or function codes
	DOWN Decrement button	Decrement of data or function codes
	Shift button	Switching between the Fault interface and the Parameter Display interface, as well as cycle-shifting the parameters shown in the Parameter Display interface to the right
	Run button	This is used for running operation under the mode of Keyboard Operation
	Stop/Reset button	In Running state, pressing this button can be used for stopping the running operation, which is constrained by the function codes P7.04; While in fault state, this can be used for resetting the faults, which is not restricted by the function codes P7.04.
	Warning/Fault reset button	In the Fault or Warning state, the faults and warnings can all be reset by pressing this combination of buttons, without influencing the actions of the current variable frequency speed control system.
	Quick multi-function button	The function of this button is determined by the function codes in P7.03
	Combination	Pressing RUN button and STOP/RST button simultaneously, the variable frequency speed control system stops freely

2) Description of functional indicator lights

Indicator light name	Description of indicator light
RUN/TUNE	Indicator light in Running state: Lights off means the variable frequency speed control system is in the Stop state; the flashing of light means the variable frequency speed control system is in the Parameter Self-study state; lights on means the variable frequency speed control system is in the Running state.
FWD/REV	Forward & Reverse indicator light: Lights off indicates the system is in the Forward state; Lights on indicates the system is in the Reverse state.
LOCAL/REMOTE	Control Mode indicator light: Lights off indicates the Keyboard Control mode; lights flashing indicates the Terminal Control state; lights on indicates the Remote Communication Control state.
TRIP	Overload Pre-alarm indicator light: lights off represents the Normal state; lights flashing represents the Overload Pre-alarm state; lights on represents the Fault state.

3) Description of unit indicator lights

Symbol characteristics	Description of symbol contents
Hz	Frequency unit
A	Current unit
V	Voltage unit
RPM	Rotation speed unit
%	Percentage

7.1.3 Description of keyboard operations

1. Description of keyboard interface hierarchies

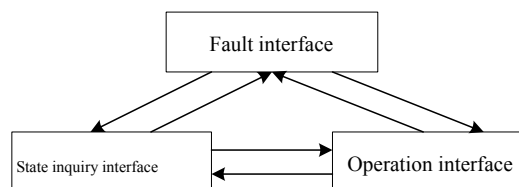

Figure 18 Converting relation drawing of the keyboard operation interfaces

The keyboard operation interfaces are divided into 3 categories of Fault interface, Status Query interface and Operation interface. The display contents are as follows:

Name	Content	Remarks
Fault interface	Displays the Warning/Fault code if it is in Warning or Fault state; displays p-off if it is in Power-off state	1) This interface does not exist in normal state, only when the high voltage power is off or it is in the state of Warning/Fault, will this interface appear. Now this interface is used as the basic interface. 2) The interface disappears after the reset of Warning/Fault state; if it is in power-off state, then the interface disappears after the high voltage power up.
Status Query interface	Displaying current bus voltage, specified frequency and other information.	1) While high voltage power up and there is no warning/fault, this interface is regarded as the basic interface. For the details, please refer to the 2 Status Query
Operation interface	Users operate the function codes in this interface.	1) Enter into this interface only when the user needs to query or modify the information of the function codes. 2) For the details, please refer to the 3 Functional parameter settings.

The introduction of the conversion among the 3 categories of interfaces:

(1) In Warning/Fault state

1) All 3 interfaces exist, Fault interface is the basic interface.

2) In the Fault interface, press **>>/SHIFT** button, enter the Status Query interface.

3) If the system is now in the last query state of the Status Query interface, press **>>/SHIFT** button, enter Fault interface.

4) In the Fault interface/Status Query interface, press **PRG/ESC** button, enter the Operation interface.

5) In the 1st level menu of the Operation interface, press **PRG/ESC** button, enter the Fault interface.

(2) In Normal state

1) There is only the Status Query interface and Operation interface; Status Query interface is the basic interface.

2) In the Status Query interface, press **PRG/ESC** button, enter the Operation interface.

3) In the 1st level menu of the Operation interface, press **PRG/ESC** button, enter the Status Query interface.

Note: The so-called Basic Interface means the interfaces displayed in the default state without any other operation.

2. State query

The State Query interface is for checking the current voltage, current, output frequency and other work-related state values of the variable frequency speed control system.

In different state (Running and Shutdown) of the variable frequency speed control system, the content of the keyboard displayed in the Query interface is specified by relevant function codes, the relations of the function codes correspondent to the state of the variable frequency speed control system and the query content are as follows:

State	The function codes correspondent to the query content
Running	During the running process of the variable frequency speed control system, the state parameters that can be queried via the keyboard are configured by the function codes P7.06, P7.07
Shutdown	When the variable frequency speed control system is in the Shutdown state, the state parameters that can be queried via the keyboard are configured by the function codes P7.08

When multiple parameters can be queried using the keyboard, the LCD keyboard can only display 3 of the parameters once, the digital keyboard can only display 1 of the parameters once.

Users can use the buttons on the keyboard to rotate right the displayed parameters. The details are introduced as follows:

Button	Operation
	Rotate the displayed parameters to the right. Display the next state in the State parameter display array. If the parameter currently displayed is the last one in the array, then the first one in the array will be displayed after rotating to the right.

Notes: the aligning sequence of the Display states in the State parameter display array is the same as that of the parameters of the corresponding function codes.

3. Functional parameter settings

The settings of functional parameters shall be completed in the Operation interface, the whole process from selecting function codes to completing the settings of function codes requires 3 levels of menus to complete. The descriptions of the 3 levels of menus are as follows:

Menu name	Menu function
1 st Level menu	Display and modify the group number of the current function code.
2 nd Level menu	Display and modify the identifier number of the current function code (Sub function codes)
3 rd Level menu	Display and modify the value of the current function code.

In the Fault interface/Parameter inquiry interface, press **PRG/ESC** button to enter the 1st level menu of the Operation interface. The group number of the function codes required to be selected can be modified by using the **▲/▼** buttons in this level of menu. Pressing **PRG/ESC** button in the 1st level menu will return to the Basic interface.

In the 1st level menu, press **DATA/ENT** button to enter the 2nd level menu of the Operation interface. In the menu of this level, we can switch the modified bit number by pressing the **>>/SHIFT** button, and modify the sub-function number below the specified bit number by pressing the **▲/▼** button. Press **PRG/ESC** button in the 2nd level menu to return to the menu of the 1st level;

In the 2nd level menu, press **DATA/ENT** button to enter the 3rd level menu of the Operation interface. In the menu of this level, we can modify the current function code (the value determined by the group number of the function codes in the menu of the 1st level and the sub-function code numbers in the menu of the 2nd level). If it is permitted now, users can modify the value of the function code. During the modification, we can select the bit number to be modified by pressing the **>>/SHIFT** button, and increase or decrease the numerical value by pressing the **▲/▼** button.

Note: Not all function codes are allowed to be modified; the function codes allowed to be modified in the current state shall have the flicker bits.

In the menu of the 3rd level, pressing the **DATA/ENT** button or the **PRG/ESC** button can both return to the menu of the 2nd level. The difference is that pressing **DATA/ENT** button indicates that this is valid for the modifications made to the menu of the 3rd level, and the sub-function code number shall be added by 1 after returning to the menu of the 2nd level; while pressing the **PRG/ESC** button indicates that this is invalid to the modifications made to the menu of the 3rd level, and the sub-function code numbers will stay the same after returning to the menu of the 2nd level.

4. Fault /Warning and Reset

When fault or warning occurs in the variable frequency speed control system, the variable frequency speed control system will be locked to Fault/Warning, now even if the condition of Fault /Warning has been eliminated; the variable frequency speed control system is still in the Fault /Warning state. The benefits of doing so is providing the capability of locking the fault or warning occurred instantaneously and occasionally, and better protection of the system.

Users must exclude the fault/warning first, and can not perform the resetting until the fault and warning have all been eliminated. Reset method: If it is in the Warning state, the reset can only be performed by pressing **STOP/RST+DATA/ENT**; if it is in the Fault state, the reset can be performed either by pressing **STOP/RST+DATA/ENT** or by pressing **STOP/RST**.

The so-called Fault/Warning resetting function means removing the locking of Fault /Warning, and checking the state of the fault or warning currently occurred in real-time. If the Fault /Warning resetting is performed in the state of Fault /Warning and the fault /Warning has been eliminated, then the current state will be switched to the normal state.

Note:

1. If the fault is not excluded, the Fault state can be switched to the normal state even by clicking.

2. The difference between Fault and Warning: Fault represents the anomaly that can cause damages; Warning represents the anomaly that can cause fault if not attached with importance. In the Fault state, the variable frequency speed control system will choose to freely shut down or cut off the high voltage according to the property of the fault; and will not affect the current operation state of the variable frequency speed control system in Warning state.

5. Automatically search for the parameters different from the ex-factory values

By setting the P7.03 to 2, after clicking the **QUICK/JOG** button, the frequency inverter will automatically search for the parameters currently different from the ex-factory values, and store them in the Quick Debugging menu according to the sequence of the function codes for the users to view and configure. The length of the shortcut menu buffer is 16, the recorded parameters will be searched by the sequence of the function codes, and when there are more than 16 parameters recorded, the parameters over 16 will not be displayed. If it displays “NULLP” after clicking **QUICK/JOG**, then it is regarded that all current parameters are the same as the ex-factory parameters.

6. Functions summary of **▲/▼** buttons

▲/▼ buttons on the keyboard are most commonly used. Here is the summary of the functions of this button.

Interface		Function
Fault interface		Invalid
Status Query interface		Increase/decrease the frequency currently configured (perform fine-tuning to the configured frequency).
Operation interface	Menu of the 1 st level	Increase/decrease the group number of the current function code
	Menu of the 2 nd level	Increase/decrease the number of the current sub-function code
	Menu of the 3 rd level	Increase/decrease the numerical value of the current function code

7.2 Touch screen

7.2.1 Introduction of the touch screen

In CHH Series high voltage variable frequency speed control systems, the touch screen is an optional device. However, the running interface of touch screen is simple and intuitive, so we recommend using this configuration.

The touch screen is connected to the main control panel via the Modbus communication protocol, which will take up the Modbus communication resource of the variable frequency speed control system. Therefore, the CHH Series high voltage variable frequency speed control systems configured by using the touch screen will no longer support the other Modbus control functions.

7.2.2 The meanings of the touch screen operations

After the power-on of the touch screen, the Login interface will first pop up, users can choose the corresponding user names and input passwords to log in. after logging in, and the main interface of the touch screen will appear. Users can click the corresponding buttons in the main interface for performing different operations.

As for some setting operations, the clicking will generate the corresponding specialized interface, which is referred to as the sub-interface. Sometimes, clicking the corresponding buttons on the sub-interface will also pop up the corresponding specialized interface for running; therefore, the sub-interface is hierarchical. In order to make the distinction, the main interface is called the 1st level interface; the specialized sub-interface popped up from the main interface is called the 2nd level interface, and so on.

For the area of numerical settings, a common setting interface will pop up after clicking to permit the user to input figures, the interfaces of this category are called Common interface, and not grouped under the category of sub-interface.

1. The main work interface of the touch screen

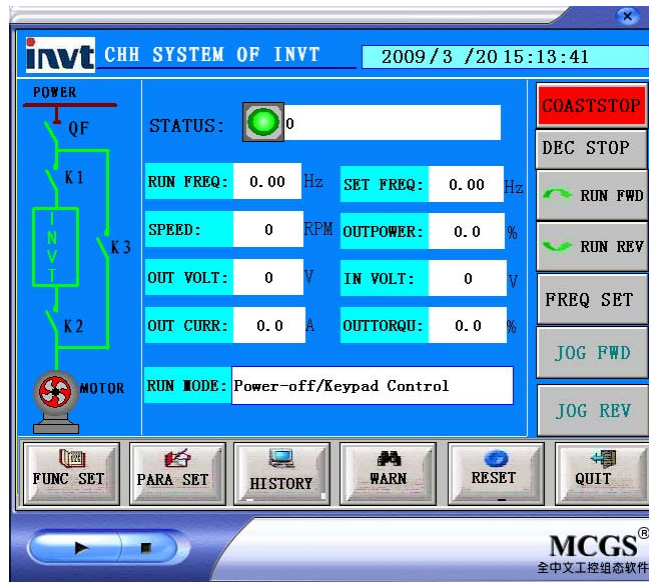

Figure 19 Schematic drawing of the touch screen main interface

The schematic drawing of the main interface of the touch screen is shown in the figure above, the main interface of which is mainly divided into the following areas:

Serial NO.	Area	Buttons and content	Meanings
1	Settings area	Function settings button	By clicking the Function Settings button, we can configure the running command channel and frequency specifying methods of the variable frequency speed control system and other setting methods related to controlling in the popped-up dialog box
		Parameters settings button	By clicking the Parameter settings button, we can configure the function codes of the variable frequency speed control system and examine the values of all function codes in the popped-up dialog box.
2	History area	Running recording button	Recording the historical start-stop information of the variable frequency speed control system
		Alarm button	Recording the historical fault information of the variable frequency speed control system
3	Operation area	Emergency stop	If the running command channel is used for communication, then after pressing this button, the variable frequency speed control system will freely stop.

		Deceleration stop	If the running command channel is used for communication, then after pressing this button, the variable frequency speed control system will stop with deceleration.
		Forward running	If the running command channel is used for communication, then after pressing this button, the variable frequency speed control system will be forward running
		Reverse running	If the running command channel is used for communication, then after pressing this button, the variable frequency speed control system will be reverse running
		Frequency settings	If the frequency specifying channel is used for communication, then after pressing this button, the dialog box will pop up for setting the running frequency of the variable frequency speed control system
		Normal inching turning	After pressing this button, the system will be running forward in the inching mode; after releasing this button, the system will stop the inching operation.
		Reverse inching turning	After pressing this button, the system will be running reversely in the inching mode; after releasing this button, the system will stop the inching operation.
4	Monitoring area	Running frequency	The actual running frequency of the variable frequency speed control system
		Setting frequency	The configured frequency of the variable frequency speed control system
		Motor speed	Displays the actual rotating speed of the current motor
		Output power	Displays the percentage taken by the output power of the current motor of the rated power
		Output voltage	The output voltage of the variable frequency speed control system
		Input voltage	The input voltage of the variable frequency speed control system
		Output current	The output current of the variable frequency speed control system
		Output torque	The actual torque output percentage of the variable frequency speed control system
		Power/Variable frequency state	It is on the left side of this area, and displays the state of all high-voltage switches of the current high voltage variable frequency speed control system in graphic mode.
		Running state	The text box above this area, displaying the high voltage variable frequency speed control system is currently in the state of Power-frequency operation, Variable frequency operation, Standby or Fault.
Running mode	Displays the Power/Variable frequency state of the variable frequency speed control system, and the specification method of the running command.		
5	Reset area	Fault reset	If any fault occurs to the variable frequency speed control system, the variable frequency speed control system will keep locking that fault until the fault is unlocked by clicking the Fault Reset. Whichever control method is used, the Fault Reset button can always unlock the fault.
6	Exit area	Exit button	Click this button to exit the current user.

2. Log-on interface of touch screen

After the frequency inverter is power on, or the user has exited the main interface, the touch screen will display the Log-on interface. There are 3 types of running staff for the Log-on interface, including:

Operators: These running staff are applicable to the operators who don't do any setting of the system but only start and stop the variable frequency speed control system.

Persons in charge: These running staff are applicable to the technical persons in charge of the organization and can perform the configuration and running of the variable frequency speed control system.

Manufacturer: These running staff can only be used for the manufacturer of the variable frequency speed control system; herein we will not make any more introductions.

The operation permissions of the Operation area owned by the running staff are as follows

	Operator	Person in charge
Settings area	Running not allowed	Running allowed
History area	Viewing allowed	Viewing allowed
Operation area	Running allowed	Running allowed
Monitoring area	Viewing allowed	Viewing allowed

Exit area	Running allowed	Running allowed
-----------	-----------------	-----------------

3. Description of 2nd level interface

1) The buttons for generating 2nd level interfaces.

The buttons for setting area and history area can both generate the 2nd level interfaces.

2) The description of the 2nd level interface popped up by clicking Function Settings button.

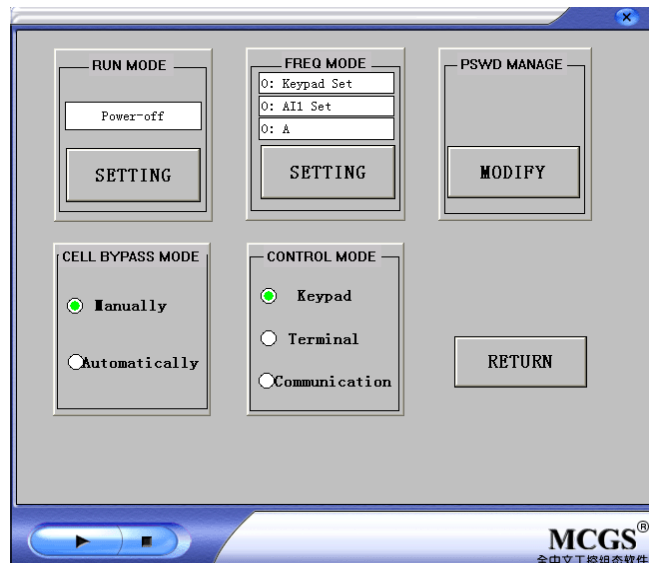

Figure 20 Schematic drawing of the Function Settings 2nd level interface

This interface is mainly for setting some commonly used control parameters, which are:

Running mode is used for controlling the Power /Variable frequency switching of the variable frequency speed control system, and this group box displays that it is currently in the state of Variable frequency, Power frequency or Power-off; the Motor running mode settings is for entering the menu of the 3rd level configured by the running mode.

Frequency mode is mainly for controlling the specification method of the running frequency. This group box displays in the sequence of: Specification method of frequency source A, Specification method of frequency source B and the actual frequency source is composed of which frequency source (s).

Password modifying is mainly for modifying the password of the Person-in-charge property.

Unit Bypass is mainly for setting the action choice after the unit fault occurs, i.e. manual bypass or automatic bypass.

Command Channel is mainly for setting the mode through which the start-stop of the variable frequency speed control system is controlled.

3) The description of the 2nd level interface popped up by clicking Parameter Settings button.

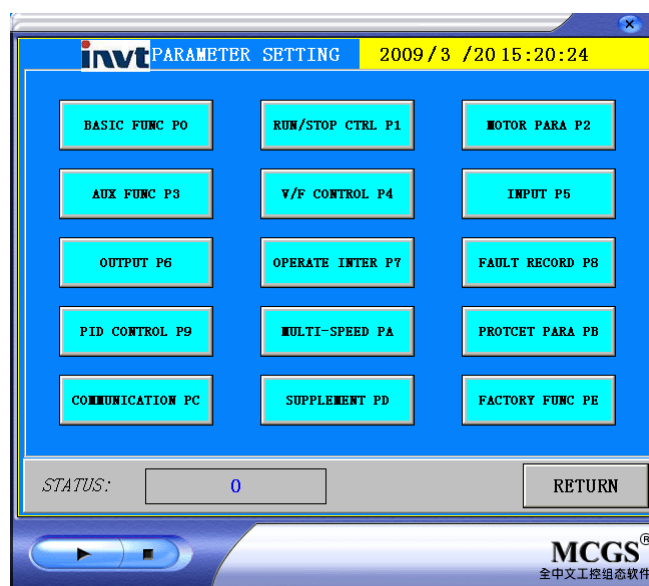

Figure 21 Schematic drawing of the Parameter Settings 2nd level interface

The upmost groups are the ones that need to be configured. After pressing the corresponding buttons, the settings

interface of the corresponding function code group will pop up. The downmost groups display the operation state, since the modification of the function codes are closely related to the operation state. The Return button is for returning to the previous menu.

4) The description of the 2nd level interface popped up by clicking Operation Recording button

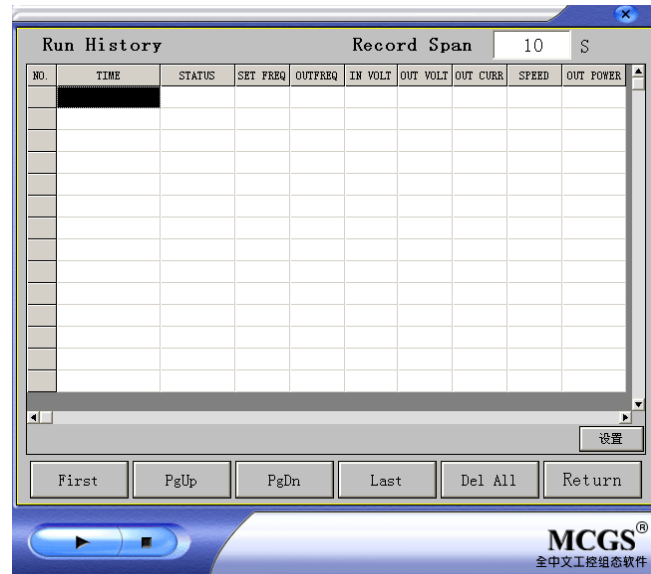

Figure 22 Schematic drawing of the Running recoding 2nd level interface

This interface is mainly for popping up the running historical records of the frequency inverter. The buttons below are for the operations of turning pages and deleting records.

5) Description of the 2nd level interface popped up by pressing Fault recording button

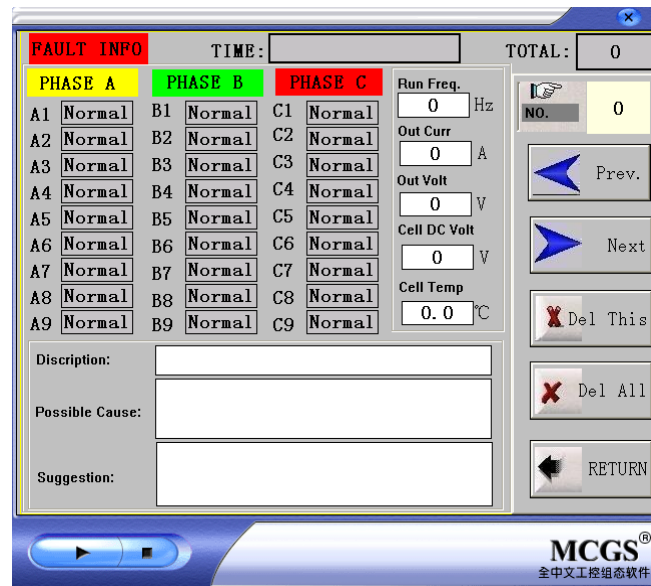

Figure 23 Schematic drawing of the Fault Recording 2nd level interface

When the user presses the Fault Recording button or Fault button, this interface will pop out. The main interface is for displaying the fault information. The Previous and Next button on the right are for querying the previous and next fault information; Delete This and Delete All buttons are for deleting the fault information the users don't need.

4. Description of 3-level interface

1) The 2nd level interface that can generate the 3rd level interface

The 2nd level interface popped up by pressing Parameter Settings button can generate the 3rd level interface.

2) Description of the Parameter Settings 3rd level interface

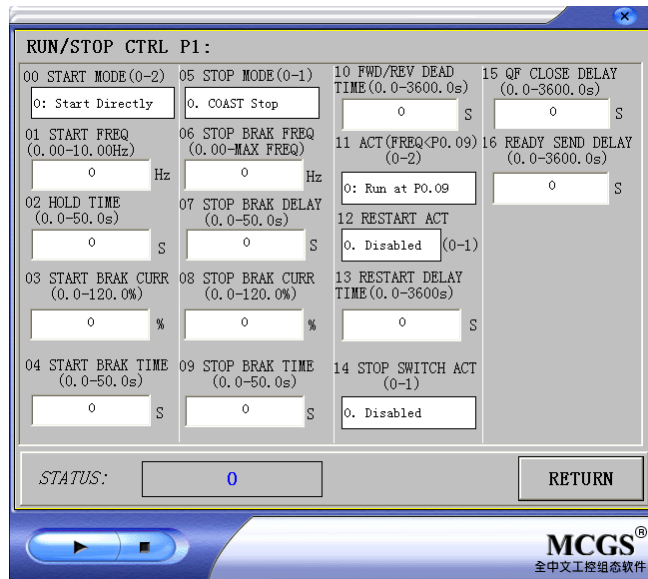

Figure 24 Parameter Settings 3rd level interface

The main interface is mainly for displaying the value and status of the function codes. Users can click corresponding function codes to perform the setting and modifying operations.

3) The interface of the 3rd level sub-menu popped up by Running Mode Settings

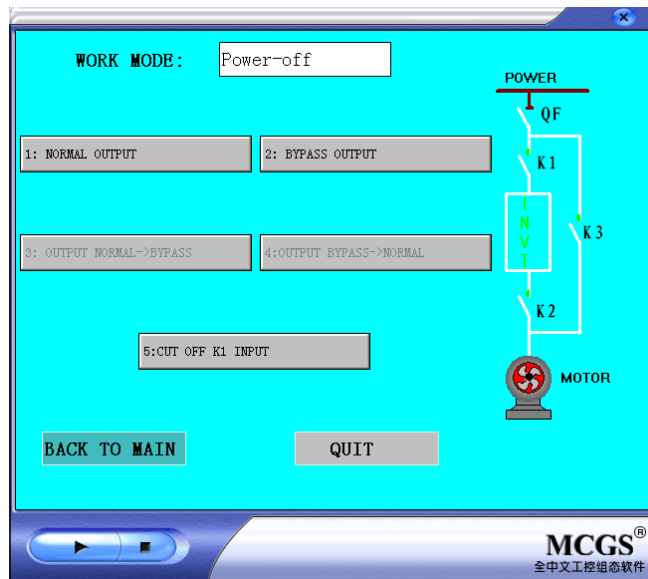

Figure 25 Schematic drawing of the Running Mode Settings 3rd level interface

Current Running Mode displays the current variable frequency speed control system is in Variable frequency, Power frequency or Power-off.

The lower-left button represents the required operations. Under the current operation, if button operation is allowed, then this button is black; and if button operation is not allowed, then this button is grey.

The lower-left graph displays the current specific action state of the contactor of the variable frequency speed control system and the distribution of the high voltage.

4) The description of the 3rd level sub-menu popped up by Frequency Mode Settings

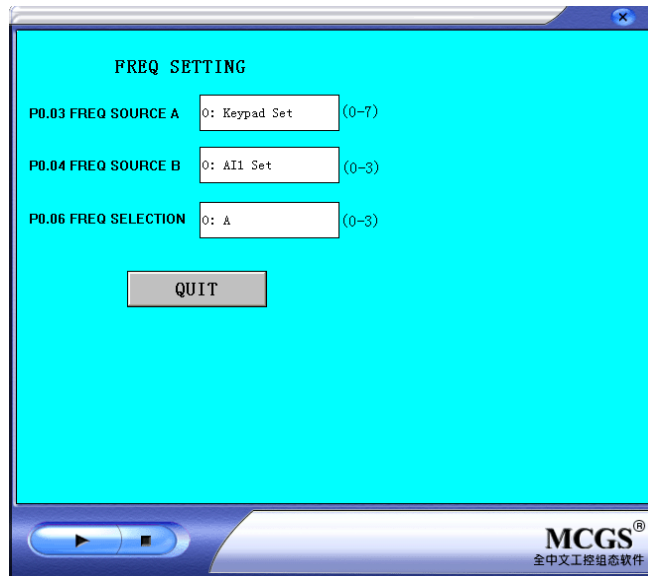

Figure 26 Schematic drawing of the Frequency Mode Settings 3rd level interface
 This interface mainly displays the settings of the 3 function codes related to the current frequency source. Clicking the white edit-box on the right of the function code will pop up the corresponding selection dialog box for selecting and setting.

5. Description of common interfaces

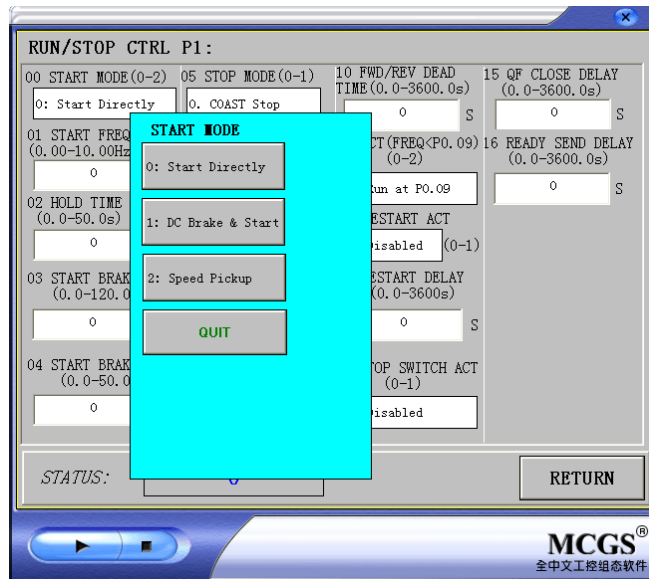

Figure 27 Schematic drawing of the common interface of Parameter Settings

As for the input of enumeration type, the enumeration interface as shown in the figure above will pop out after clicking; users can complete the settings by clicking the corresponding items.

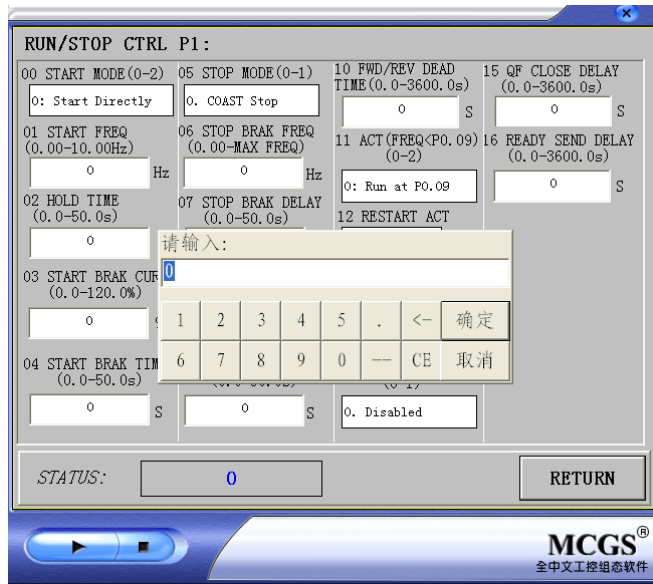

Figure 28 Schematic drawing of the common interface of Parameter Number Settings
 As for the input of number type, the settings interface as shown in the figure above will pop out after clicking;
 users can carry out the settings of numbers by running the popped-out soft keyboard.

Chapter 8 DETAILED FUNCTIONAL DESCRIPTION

P0 Group Basic Function

Function Code	Name	Description	Setting Range	Factory Setting
P0.00	Speed control mode	0: V/F control 1: Vector control(reserved)	0~1	0

Select inverter speed control mode:

0:V/F control

V/F control: It is suitable for general purpose application such as pumps, fans etc. it also can be drive several motors by one inverter.

Function Code	Name	Description	Setting Range	Factory Setting
P0.01	Run command source	0: Keypad (LED extinguished) 1: Terminal (LED flickering) 2: Communication (LED lights on)	0~2	0

The control commands of inverter include: start, stop, forward run, reverse run, jog, fault reset and so on.

0: Keypad "(LOCAL/REMOTLED" extinguished)

Both **RUN** and **STOP/RST** key are used for running command control. If Multifunction key **QUICK/JOG** is set as FWD/REV switching function (P7.03 is set to be 1), it will be used to change the rotating orientation. **In running status, pressing **RUN** and **STOP/RST** in the same time will cause the inverter coast to stop.**

1: Terminal (LED flickering)

The operation, including forward run, reverse run, forward jog, reverse jog etc. can be controlled by multifunctional input terminals.

2: Communication (LED lights on)

The operation of inverter can be controlled by host through communication(Modbus).

Notice:CHH series high voltage inverter communicate channel is used by touch screen.

Function Code	Name	Description	Setting Range	Factory Setting
P0.02	UP/DOWN setting	0: Valid, save UP/DOWN value when power off 1: Valid, do not save UP/DOWN value when power off 2: Invalid 3:Valid during running, clear when power off	0~3	0

0: Valid, save UP/DOWN value when power off.

User can adjust the reference frequency by UP/DOWN. The value of UP/DOWN can be saved when power off.

1: Valid, do not save UP/DOWN value when power off.

User can adjust the reference frequency by UP/DOWN, but the value of UP/DOWN will not be saved

when power off.

2: Invalid.

User can not adjust the reference frequency by UP/DOWN. The value of UP/DOWN will be cleared if P0.02 is set to 2.

3: Valid during running, clear when power off

User can adjust the reference frequency by UP/DOWN when inverter is running. When inverter power off, the value of UP/DOWN will be cleared

Notice:

- UP/DOWN function can be achieved by keypad (▲) and (▼) and multifunctional terminals.
- Reference frequency can be adjusted by UP/DOWN.
- UP/DOWN has highest priority which means UP/DOWN is always active no matter which frequency command source is.
- When the factory setting is restored (P0.18 is set to be 1), the value of UP/DOWN will be cleared.

Notice: The value of UP/DOWN will be cleared when user restore the inverter

Function Code	Name	Description	Setting Range	Factory Setting
P0.03	Frequency A command source	0: Keypad 1: AI1 2: AI3 3: HDI1 4: Simple PLC 5: Multi-Step speed 6: PID 7: Communication	0~7	0
P0.04	Frequency B command source	0: AI1 1: AI2 2: AI3 3: HDI	0~3	0
P0.05	Scale of frequency B command	0: Maximum frequency 1: Frequency A command	0~1	0
P0.06	Frequency command selection	0:A 1:B 2:A+B 3:Max(A,B)	0~3	0

This parameter can be used to select the reference frequency command.

0: Only frequency command source A is active.

1: Only Frequency command source B is active.

2: Both Frequency command source A and B are active.

Reference frequency = reference frequency A + reference frequency B.

3: Both Frequency command source A and B are active.

Reference frequency = Max (reference frequency A, reference frequency B).

CHH series inverter have two command sources A and B channel, A command source is general channel, B command source is assistant channel, Real frequency setting consist of the two channels, Frequency command selection refer to P0.05 and P0.06.

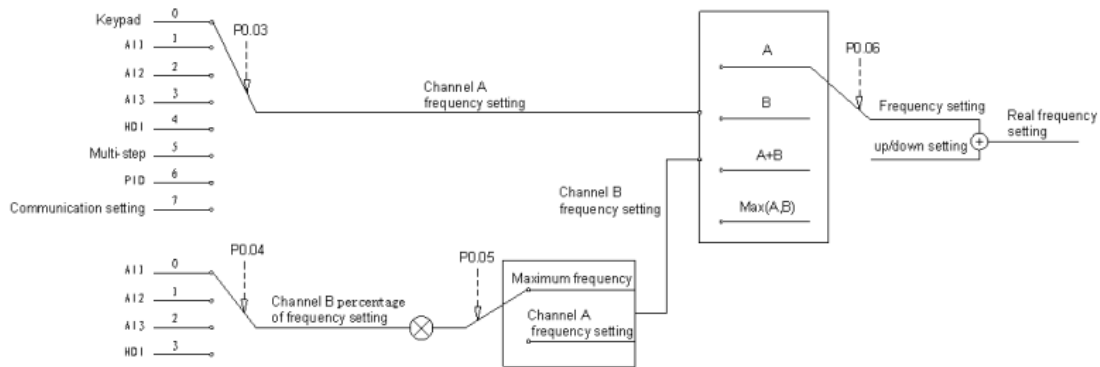

Figure 29 A,B channel combination diagram

Notice:

1. Current or voltage signals of analog input is selectable by jumper.
2. AI1, AI2, AI3 is programmable analog input terminals, Please refer to description of P5 group.
3. When the command source is HDI, Please set its percentage refer to description of P5 group.
4. Standard of HDI setting: 24V,0.0~50.0kHz.
5. when P0.03=5, inverter run in multi-step, Please refer to P5 group terminal to select running stage, according to PA group to select current running frequency.
6. Multi-step speed is priority.
7. P0.03=5 :when multi-step terminal is 0, A command source come from first stage frequency setting, UP/DOWN setting is available.
8. P0.03=7: user can write A command source in 2000H location through Modbus protocol. Please refer to communication parts.
9. P0.06 is used to set general frequency source, status of P0.06(0,1,2) switched by terminal function in P5 group.

Function Code	Name	Description	Setting Range	Factory Setting
P0.07	Maximum frequency	P0.08~120.00Hz	P0.08~120.00Hz	50.00Hz

Notice:

- The frequency reference should not exceed maximum frequency.
- Actual acceleration time and deceleration time are determined by maximum frequency. Please refer to description of P0.11 and P0.12.

Function Code	Name	Description	Setting Range	Factory Setting
P0.08	Upper frequency limit	P0.09~ P0.07	P0.09~ P0.07	50.00Hz
P0.09	Lower frequency limit	0.00 ~ P0.08	0.00 ~ P0.08	0.00Hz

Notice:

- Upper frequency limit should not be greater than the maximum frequency (P0.07).
- Lower frequency limit should not be greater than upper frequency limit (P0.08).
- Restrictions on the relationship between frequency: Maximum frequency ≥ Upper frequency ≥ setting frequency ≥ lower frequency.

Function Code	Name	Description	Setting Range	Factory Setting
P0.10	Keypad reference frequency	0.00 ~ P0.07	0.00 ~ P0.07	50.00Hz

P0.03=0, this parameter is the initial value of inverter reference frequency.

Function Code	Name	Description	Setting Range	Factory Setting
P0.11	Acceleration time ₀	0.1~3600.0s	0.1~3600.0s	Depends on model
P0.12	Deceleration time ₀	0.1~3600.0s	0.1~3600.0s	Depends on model

Acceleration time is the time of accelerating from 0Hz to maximum frequency (P0.07). Deceleration time is the time of decelerating from maximum frequency (P0.07) to 0Hz. Please refer to following figure.

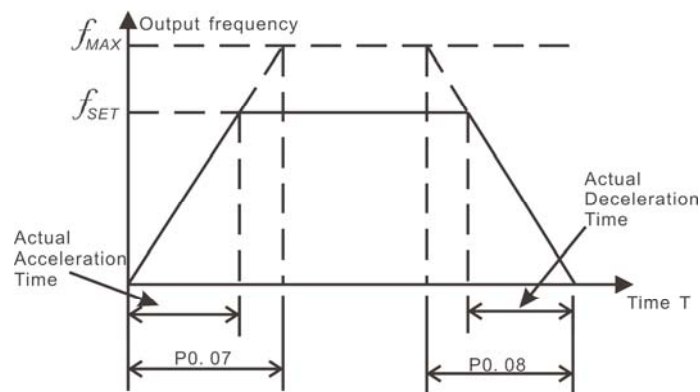

Figure 30 Acceleration and Deceleration time

When the reference frequency is equal to the maximum frequency, the actual acceleration and deceleration time will be equal to the P0.11 and P0.12 respectively.

When the reference frequency is less than the maximum frequency, the actual acceleration and deceleration time will be less than the P0.11 and P0.12 respectively.

The actual acceleration (deceleration) time = P0.11 (P0.12) * reference frequency/P0.07.

CHV series inverter has 4 groups of acceleration and deceleration time.

1st:P0.11,P0.12;

2nd:P3.00,P3.01;

3rd:P3.02,P3.03;

4th:P3.04,P3.05.

The acceleration and deceleration time can be selected by combination of multifunctional ON-OFF input terminals determined by P5 Group.

Function Code	Name	Description	Setting Range	Factory Setting
P0.13	Running direction selection	0: Forward 1: Reverse 2: Forbid reverse	0~2	0

Notice:

- The rotation direction of motor is corresponding to the wiring of motor.
- When the factory setting is restored (P0.18 is set to be 1), the rotation direction of motor may be changed. Please be cautious to use.

If P0.13 is set to 2, user can not change rotation direction of motor by **QUICK/JOG** or terminal.

Function Code	Name	Description	Setting Range	Factory Setting
P0.14	Carrier frequency setting	0.5~2.0kHz	0.5~2.0kHz	Depends on model

Notice:

- The factory setting is optimal in most cases. Modification of this parameter is not recommended.

If the carrier frequency exceeds the factory setting, the inverter must be derated because the higher carrier frequency will cause more switching loss, higher temperature rise of inverter and stronger electromagnetic interference.

Function Code	Name	Description	Setting Range	Factory Setting
P0.15	Motor parameters autotuning	0: No action 1: autotuning(Reserved)	0~1	0
P0.16	Restore parameters	0: No action 1: Restore factory setting 2: Clear fault records 3: Restore parameters for injection molding machine	0~2	0

0: No action

1: Inverter restores all parameters to factory setting except P2 group.

2: Inverter clear all fault records.

3: Inverter restores special parameters for injection molding machine.

This function code will restore to 0 automatically when complete the function operation.

Function Code	Name	Description	Setting Range	Factory Setting
P0.17	AVR function	0: Disabled 1: Enabled all the time 2: Disabled during deceleration	0~2	1

AVR (Auto Voltage Regulation) function ensure the output voltage of inverter stable no matter how the DC bus voltage changes. During deceleration, if AVR function is disabled, the deceleration time will be short but the current will be big. If AVR function is enabled all the time, the deceleration time will be long but the current will be small.

P1 Group Start and Stop Control

Function Code	Name	Description	Setting Range	Factory Setting
P1.00	Start Mode	0: Start directly 1: DC braking and start 2: Speed tracking and start	0~2	0

0: Start directly: Start the motor at the starting frequency determined by P1.01.

1: DC braking and start: Inverter will output DC current firstly and then start the motor at the starting frequency. Please refer to description of P1.03 and P1.04. It is suitable for the motor which have small inertia load and may reverse rotation when start.

2: Speed tracking and start: Inverter detects the rotation speed and direction of motor, then start running to its reference frequency based on current speed. This can realize smooth start of rotating motor with big inertia load when instantaneous power off.

Function Code	Name	Description	Setting Range	Factory Setting
P1.01	Starting frequency	0.00~10.00Hz	0.00~10.00Hz	0.50Hz
P1.02	Hold time of starting frequency	0.0~50.0s	0.0~50.0s	0.0s

Set proper starting frequency can increase the starting torque.

- If the reference frequency is less than starting frequency, inverter will be at stand-by status. The indicator of **RUN/TUNE** lights on, inverter has no output.
- The starting frequency could be less than the lower frequency limit (P0.09).
- P1.01 and P1.02 take no effect during FWD/REV switching.

Function Code	Name	Description	Setting Range	Factory Setting
P1.03	DC Braking current before start	0.0~120.0%	0.0~120.0%	0.0%
P1.04	DC Braking time before start	0.0~50.0s	0.0~50.0s	0.0s

When inverter starts, it performs DC braking according to P1.03 firstly, then start to accelerate after P1.04.

Notice:

- **DC braking will take effect only when P1.00 is set to be 1.**
- **DC braking is invalid when P1.04 is set to be 0.**

The value of P1.03 is the percentage of rated current of inverter. The bigger the DC braking current, the greater the braking torque.

Function Code	Name	Description	Setting Range	Factory Setting
P1.05	Stop Mode	0:Deceleration to stop 1:Coast to stop	0~1	0

0: Deceleration to stop

When the stop command takes effect, the inverter decreases the output frequency according to P1.05 and the selected acceleration/deceleration time till stop.

1: Coast to stop

When the stop command takes effect, the inverter blocks the output immediately. The motor coasts to stop by its mechanical inertia.

Function Code	Name	Description	Setting Range	Factory Setting
P1.06	Starting frequency of DC braking	0.00~10.00Hz	0.00~10.00	0.00Hz
P1.07	Waiting time before DC braking	0.0~50.0s	0.0~50.0s	0.0s
P1.08	DC braking current	0.0~120.0%	0.0~120.0%	0.0%
P1.09	DC braking time	0.0~50.0s	0.0~50.0s	0.0s

Starting frequency of DC braking: Start the DC braking when running frequency reaches starting frequency determined by P1.09.

Waiting time before DC braking: Inverter blocks the output before starting the DC braking. After this waiting time, the DC braking will be started. It is used to prevent over-current fault caused by DC braking at high speed.

DC braking current: The value of P1.11 is the percentage of rated current of inverter. The bigger the DC braking current, the greater the braking torque.

DC braking time: The time used to perform DC braking. If the time is 0, the DC braking will be invalid.

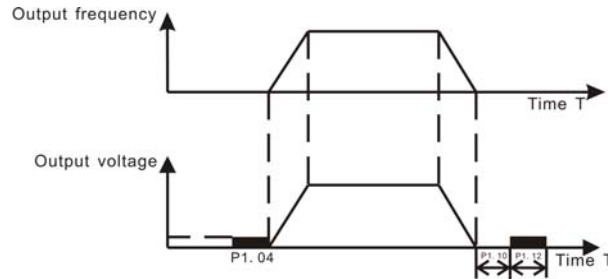

Figure 31 DC braking diagram

Function Code	Name	Description	Setting Range	Factory Setting
P1.10	Dead time of FWD/REV	0.0~3600.0s	0.0~3600.0s	0.0s

Set the hold time at zero frequency in the transition between forward and reverse running. It is shown as following figure:

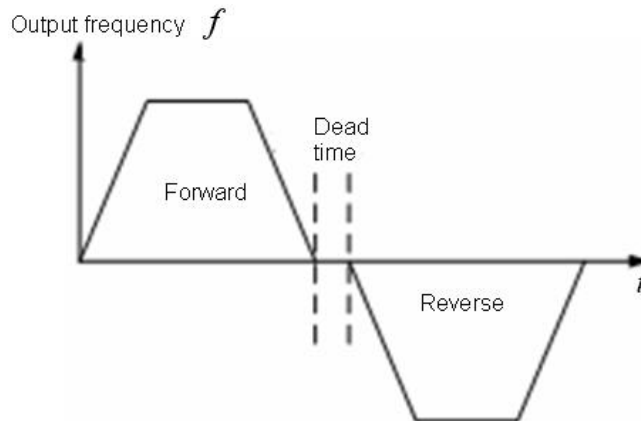

Figure 32 FWD/REV dead time diagram

Function Code	Name	Description	Setting Range	Factory Setting
P1.11	Action when running frequency is less than lower frequency limit	0: Running at the lower frequency limit 1: Stop 2: Stand-by	0~2	0

0: Running at the lower frequency limit (P0.09): The inverter runs at P0.09 when the running frequency is less than P0.09.

1: Stop: This parameter is used to prevent motor running at low speed for a long time.

2: Stand-by: Inverter will stand-by when the running frequency is less than P0.09. When the reference frequency is higher than or equal to P0.09 again, the inverter will start to run automatically.

Function Code	Name	Description	Setting Range	Factory Setting
---------------	------	-------------	---------------	-----------------

P1.12	Restart after power off	0: Disabled 1: Enabled	0~1	0
P1.13	Delay time for restart	0.0~3600.0s	0.0~3600.0s	0.0s

0: Disabled: Inverter will not automatically restart when power on again until run command takes effect.
 1: Enabled: When inverter is running, after power off and power on again, if run command source is keypad control (P0.01=0) or communication control (P0.01=2), inverter will automatically restart after delay time determined by P1.16; if run command source is terminal control (P0.01=1), inverter will automatically restart after delay time determined by P1.16 only if FWD or REV is active.

Notice:

- **If P1.15 is set to be 1, it is recommended that start mode should be set as speed tracing mode (P1.00=2).**
- **This function may cause the inverter restart automatically, please be cautious.**

Function Code	Name	Description	Setting Range	Factory Setting
P1.14	High voltage switching action select when stopping	0:Cut off high voltage supply 1:Holding	0~1	1

The function of P1.14 decide whether cut off high voltage automatically after system power off
 0:Cut off high voltage: system will stop according to instruction.cut off the main circuit high voltage automatically.
 1:Holding: system will stop according to instruction, but do not cut off high voltage automatically until receiving high voltage breaking signals.

Function Code	Name	Description	Setting Range	Factory Setting
P1.15	Waiting time of switching on	0.0~3600.0s	0.0~3600.0s	10.0s

System receive switching on signals, P1.15 is the waiting time which contain switching cabinet action time, system fault self-testing time and sending enable signal time of high voltage switching on
 The waiting time is used for protecting our unit from assault because of short time between adjacent switching on.

Function Code	Name	Description	Setting Range	Factory Setting
P1.16	Waiting time of running in order.	0.0~3600.0s	0.0~3600.0s	10.0s

The waiting time of running in order is calculated from finished charging of DC bus to signal sending of running in order to upgrade DCS after Vacuum contactor high voltage switching on.
 The time is used to make sure DC bus Charging competely reducing the assault of Grid voltage.

P2 Group Motor Parameter

Function Code	Name	Description	Setting Range	Factory Setting
P2.00	Inverter Model	0:asynchronous motor 1:synchronous motor(Reserved)	0~1	Depends on model
P2.01	Motor rated power	4.0~7100.0kW	4.0~5000.0kW	Depends on model

P2.02	Motor rated frequency	10.00~P0.07	10.00~P0.07	50.00Hz
P2.03	Motor rated speed	1~36000rpm	1~36000rpm	Depends on model
P2.04	Motor rated voltage	0~20000V	0~20000V	Depends on model
P2.05	Motor rated current	0.8~3000.0A	0.8~3000.0A	Depends on model

Notice:

- In order to achieve superior performance, please set these parameters according to motor nameplate, then perform autotuning.
- The power rating of inverter should match the motor. If the bias is too big, the control performances of inverter will be deteriorated distinctly.
- Reset P2.05 can initialize P2.06~P2.10 automatically.

Function Code	Name	Description	Setting Range	Factory Setting
P2.06	Motor stator resistance	0.001~65.535Ω	0.001~65.535Ω	Depends on model
P2.07	Motor rotor resistance	0.001~65.535Ω	0.001~65.535Ω	Depends on model
P2.08	Motor leakage inductance	0.1~6553.5mH	0.1~6553.5mH	Depends on model
P2.09	Motor mutual inductance	0.1~6553.5mH	0.1~6553.5mH	Depends on model
P2.10	Current without load	0.01~655.35A	0.01~655.35A	Depends on model

The parameters from P2.06~P2.10 are preserved temporarily in V/F control.

P3 Group Auxiliary function

Function Code	Name	Description	Setting Range	Factory Setting
P3.00	Acceleration time 1	0.1~3600.0s	0.1~3600.0s	Depends on model
P3.01	Deceleration time 1	0.1~3600.0s	0.1~3600.0s	Depends on model
P3.02	Acceleration time 2	0.1~3600.0s	0.1~3600.0s	Depends on model
P3.03	Deceleration time 2	0.1~3600.0s	0.1~3600.0s	Depends on model
P3.04	Acceleration time 3	0.1~3600.0s	0.1~3600.0s	Depends on model
P3.05	Deceleration time	0.1~3600.0s	0.1~3600.0s	Depends

	3		on model
--	---	--	----------

For details, please refer to description of P0.11 and P0.12.

Function Code	Name	Description	Setting Range	Factory Setting
P3.06	Jog reference	0.00~P0.07	0.00~P0.07	5.00Hz
P3.07	Jog acceleration time	0.1~3600.0s	0.1~3600.0s	Depends on model
P3.08	Jog deceleration time	0.1~3600.0s	0.1~3600.0s	Depends on model

The meaning and factory setting of P3.07 and P3.08 is the same as P0.11 and P0.12. No matter what the value of P1.00 and P1.08 are, jog will start as start directly mode and stop as deceleration to stop mode.

Function Code	Name	Description	Setting Range	Factory Setting
P3.09	Skip frequency 1	0.00~P0.07	0.00~P0.07	0.00Hz
P3.10	Skip frequency bandwidth 1	0.00~P0.07	0.00~P0.07	0.00Hz
P3.11	Skip frequency 2	0.00~P0.07	0.00~P0.07	0.00Hz
P3.12	Skip frequency bandwidth 2	0.00~P0.07	0.00~P0.07	0.00Hz

By means of setting skip frequency, the inverter can keep away from the mechanical resonance with the load. P8.09 and P8.10 are centre value of frequency to be skipped.

Notice:

- If P8.11 is 0, the skip function is invalid.
- If both P8.09 and P8.10 are 0, the skip function is invalid no matter what P8.11 is.
- Operation is prohibited within the skip frequency bandwidth, but changes during acceleration and deceleration are smooth without skip.

The relation between output frequency and reference frequency is shown in following figure.

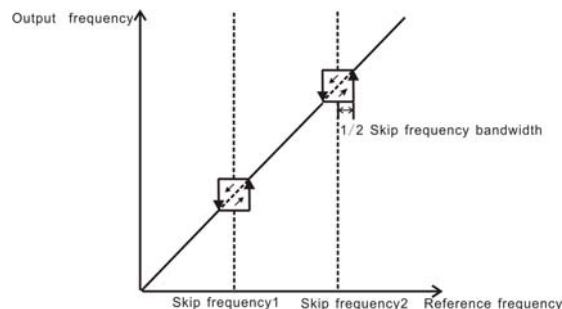

Figure 33 Skip frequency diagram

Function Code	Name	Description	Setting Range	Factory Setting
P3.13	Auto reset times	0~3	0~3	0
P3.14	Reset interval	0.1~100.0s	0.1~100.0s	1.0s

Auto reset function can reset the fault in preset times and interval. When P3.13 is set to be 0, it means “auto reset” is disabled and the protective device will be activated in case of fault.

Notice:

- The fault such as OUT 1, OUT 2, OUT 3, OH1 and OH2 cannot be reset automatically.
- If fault has not occurred for ten minutes after the fault is reset, inverter will automatically clear the previous times of auto reset.

Function Code	Name	Description	Setting Range	Factory Setting
P3.15	FDT level	0.00~P0.07	0.00~P0.07	50.00Hz
P3.16	FDT lag	0.0~100.0%	0.0~100.0%	5.0%

When the output frequency reaches a certain preset frequency (FDT level), output terminal will output an ON-OFF signal until output frequency drops below a certain frequency of FDT level (FDT level - FDT lag), as shown in following figure.

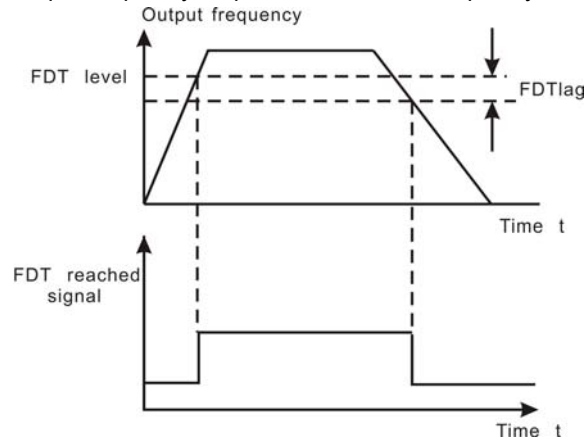

Figure 34 FDT Level diagram

Notice:FDT lag is relative to the percentage of FDT level

Function Code	Name	Description	Setting Range	Factory Setting
P3.17	Frequency arrive detecting range	0.0~100.0%	0.0~100.0%	0.0%

When output frequency is within the detecting range of reference frequency, an ON-OFF signal will be output.

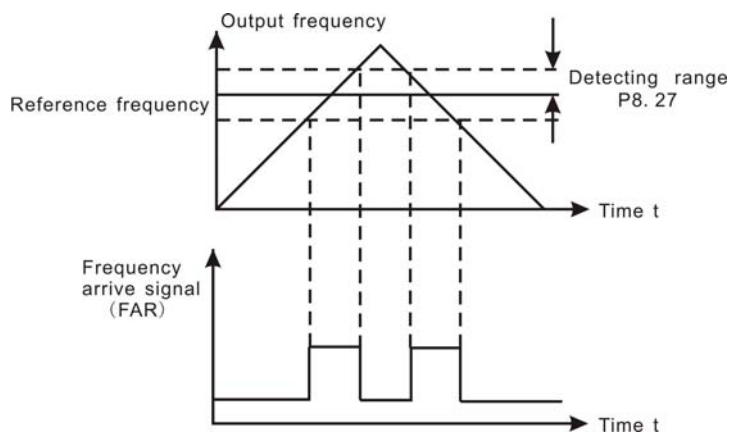

Figure 35 Frequency arriving detection diagram.

Notice:Frequency arrive detecting range is relative to the percentage of P0.07

Function Code	Name	Description	Setting Range	Factory Setting
P3.18	Over modulation selectiong	0:invalid	0~1	0

		1:valid		
--	--	---------	--	--

Using P3.18 to increase utilization of DC bus to raise output voltage when system work with full load and low grid voltage(85% rated voltage below) for long time.

Function Code	Name	Description	Setting Range	Factory Setting
P3.19	Operation mode of cooling fans	0: Automatics stopping 1: Operating all the time	0~1	0

0: Automatic stopping: Cooling fans works during system operation time, the fans stop after 30s of the system stopped.

1:The fan works all the time when the system power on.

Function Code	Name	Description	Setting Range	Factory Setting
P3.20	Alarm reset intervals	0.1~3600.0s, 0.0Alarm function invalid	0.0~3600.0s	0.0s

Notice:

Alarm reset intervals is used for alarm when system come out unusual status, which is not serious enough cause damage, But it may lead to error.

User can use P3.20 to select whether it need alarm report or not and reset intervals.

P4 Group V/F Control

The parameters of the Group only valid for V/F control(P0.00=0)

Function Code	Name	Description	Setting Range	Factory Setting
P4.00	V/F curve selection	0:Linear curve 1: User-defined curve 2: Torque_stepdown curve (1.3 order) 3: Torque_stepdown curve (1.7 order) 4: Torque_stepdown curve (2.0 order)	0~4	0

0: Linear curve. It is applicable for normal constant torque load.

1: User-defined curve. It can be defined through setting (P4.03~P4.08).

2~4: Torque_stepdown curve. It is applicable for variable torque load, such as blower, pump and so on.

Please refer to following figure.

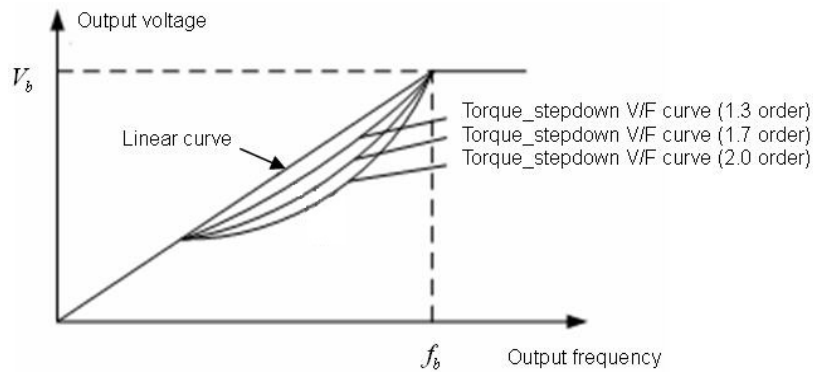

Figure36 Multiple V/F curve diagram

Function Code	Name	Description	Setting Range	Factory Setting
P4.01	Torque boost	0.0~10.0%	0.0~10.0%	0.1%
P4.02	Torque boost cut-off	0.0~50.0%	0.0~50.0%	20.0%

Torque boost will take effect when output frequency is less than cut-off frequency of torque boost (P4.02). Torque boost can improve the torque performance of V/F control at low speed.

The value of torque boost should be determined by the load. The heavier the load, the larger the value.

Notice: This value should not be too large, otherwise the motor would be over-heat or the inverter would be tripped by over-current or over-load.

If P4.01 is set to 0, the inverter will boost the output torque according to the load automatically.

Please refer to following diagram.

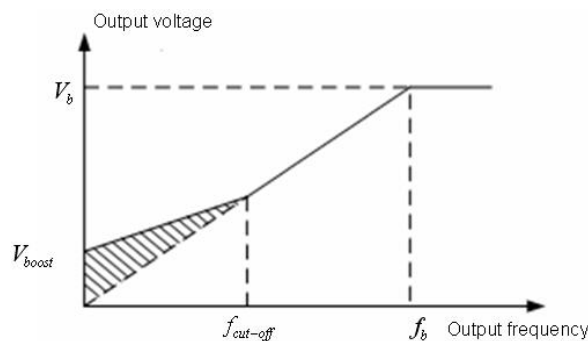

Figure 37 Torque boost diagram.

Function Code	Name	Description	Setting Range	Factory Setting
P4.03	V/F slip compensation	0.0~200.0%	0.0~200.0%	0.0%

The motor's slip changes with the load torque, which results in the variance of motor speed. The inverter's output frequency can be adjusted automatically through slip compensation according to the load torque. Therefore the change of speed due to the load change can be reduced. The value of compensated slip is dependent on the motor's rated slip which can be calculated as below:

$$P4.09 = f_b - n * P / 60$$

Where f_b is motor rated frequency (P2.02), n is motor rated speed (P2.03), and P is pole pairs of motor.

Function Code	Name	Description	Setting Range	Factory Setting
P4.04	Auto energy saving selection	0:energysaving invalid 1:energysaving valid	0~1	0

When P4.11 is set to be 1, while there is a light load, it will reduce the inverter output voltage and saves

energy.

Notice:The function have particular effect to fan,pumps ect

Function Code	Name	Description	Setting Range	Factory Setting
P4.05	V/F frequency 1	0.00~P4.07	0.00~P4.07	0.00Hz
P4.06	V/F voltage 1	0.0~100.0%	0.0~100.0%	0.0%
P4.07	V/F frequency 2	P4.05~P4.09	P4.05~P4.09	0.00Hz
P4.08	V/F voltage2	0.0~100.0%	0.0~100.0%	0.0%
P4.09	V/F frequency 3	P4.07~P2.01	P4.07~P2.02	0.00Hz
P4.10	V/F voltage 3	0.0~100.0%	0.0~100.0%	0.0%

This function is only active when P4.00 is set to be 1. P4.03~P4.08 are used to set the user-defined V/F curve. The value should be set according to the load characteristic of motor.

Notice:

- $0 < V1 < V2 < V3 < \text{rated voltage}$.
- $0 < f1 < f2 < f3 < \text{rated frequency}$.
- The voltage corresponding to low frequency should not be set too high, otherwise it may cause motor overheat or inverter fault

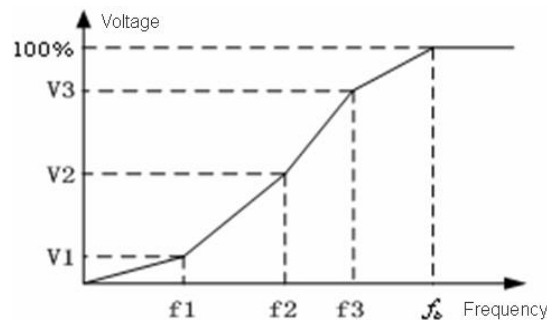

Figure 38 V/F curve setting diagram.

Notice:V/F voltage is relative to percentage of motor rated voltage(P2.04)

Function Code	Name	Description	Setting Range	Factory Setting
P4.11	Modulate waveform	0:SPWM 1 1:SPWM 2	0~1	0

P4.11 is used to select the way of modulate waveform:

0:SPWM 1, sine waveform with triple-harmonics

1:SPWM 2: standard sine waveform

P5 Group Input terminals

CHH series have 16 multifunction digital input terminals,3 analog input terminals and 1 high speed pulse input terminal.

Function Code	Name	Description	Setting Range	Factory Setting
P5.00	S1 Terminal function	0~39	0~39	0
P5.01	S2 Terminal function	0~39	0~39	0
P5.02	S3 Terminal function	0~39	0~39	0
P5.03	S4 Terminal function	0~39	0~39	0

P5.04	S5 Terminal function	0~39	0~39	0
P5.05	S6 Terminal function	0~39	0~39	0
P5.06	S7 Terminal function	0~39	0~39	0
P5.07	S8 Terminal function	0~39	0~39	0
P5.08	S9 Terminal function	0~39	0~39	0
P5.09	S10 Terminal function	0~39	0~39	0
P5.10	S11 Terminal function	0~39	0~39	0
P5.11	S12 Terminal function	0~39	0~39	0
P5.12	S13 Terminal function	0~39	0~39	0
P5.13	S14 Terminal function	0~39	0~39	0
P5.14	S15 Terminal function	0~39	0~39	0
P5.15	S16 Terminal function	0~39	0~39	0

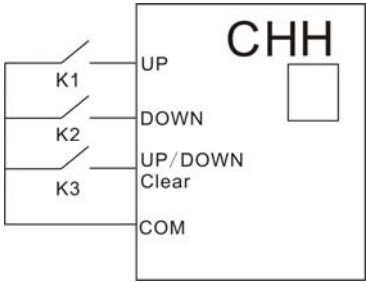
Setting value	Function	Description
0	Invalid	Please set unused terminals to be invalid to avoid malfunction.
1	Forward	Please refer to description of P5.18.
2	Reverse	
3	3-wire control	Please refer to description of P5.18.
4	Jog forward	Please refer to description of P3.06~P3.08.
5	Jog reverse	
6	Coast to stop	The inverter blocks the output immediately. The motor coasts to stop by its mechanical inertia.
7	Reset fault	Resets faults that have occurred. It has the same function as STOP/RST .
8	External fault normal close input	Stop the inverter and output a alarm when a fault occurs in a peripheral device.
9	External fault normal Open input	
10	Up command	<p>The reference frequency of inverter can be adjusted by UP command and DOWN command.</p> 
11	DOWN command	
12	Clear UP/DOWN	
13	Clear UP/DOWN (Temporary)	

Setting value	Function	Description																
14	ACC/DEC time selection1	<p>4 groups of ACC/DEC time can be selected by the combination of these two terminals.</p> <table border="1"> <thead> <tr> <th>ACC/DEC time selection 2</th> <th>ACC/DEC time selection1</th> <th>ACC/DEC time</th> </tr> </thead> <tbody> <tr> <td>OFF</td> <td>OFF</td> <td>ACC/DEC time 0 (P0.11、 P0.12)</td> </tr> <tr> <td>OFF</td> <td>ON</td> <td>ACC/DEC time 1 (P3.00、 P3.01)</td> </tr> <tr> <td>ON</td> <td>OFF</td> <td>ACC/DEC time 2 (P3.02、 P3.03)</td> </tr> <tr> <td>15</td> <td>ACC/DEC time selection 2</td> <td>ACC/DEC time 3 (P3.04、 P3.05)</td> </tr> </tbody> </table>	ACC/DEC time selection 2	ACC/DEC time selection1	ACC/DEC time	OFF	OFF	ACC/DEC time 0 (P0.11、 P0.12)	OFF	ON	ACC/DEC time 1 (P3.00、 P3.01)	ON	OFF	ACC/DEC time 2 (P3.02、 P3.03)	15	ACC/DEC time selection 2	ACC/DEC time 3 (P3.04、 P3.05)	
ACC/DEC time selection 2	ACC/DEC time selection1		ACC/DEC time															
OFF	OFF		ACC/DEC time 0 (P0.11、 P0.12)															
OFF	ON		ACC/DEC time 1 (P3.00、 P3.01)															
ON	OFF	ACC/DEC time 2 (P3.02、 P3.03)																
15	ACC/DEC time selection 2	ACC/DEC time 3 (P3.04、 P3.05)																
16	Multi-step speed reference1	<p>16 steps speed control can be realized by the combination of these four terminals. For details, please refer to following multi-step speed reference terminal status and according step value table:</p>																
17	Multi-step speed reference 2																	
18	Multi-step speed reference 3																	
19	Multi-step speed reference 4																	
20	Multi-step speed pause	Can shield the function of multi-speed terminals and keep the set value as the current status.																
21	Switch between A and B	<table border="1"> <thead> <tr> <th>P0.06 Terminal action</th> <th>A</th> <th>B</th> <th>A+B</th> </tr> </thead> <tbody> <tr> <td>13 valid</td> <td>B</td> <td>A</td> <td></td> </tr> <tr> <td>14 valid</td> <td>A+B</td> <td></td> <td>A</td> </tr> <tr> <td>15 valid</td> <td></td> <td>A+B</td> <td>B</td> </tr> </tbody> </table>	P0.06 Terminal action	A	B	A+B	13 valid	B	A		14 valid	A+B		A	15 valid		A+B	B
P0.06 Terminal action	A		B	A+B														
13 valid	B		A															
14 valid	A+B			A														
15 valid		A+B	B															
22	Switch between A and A+B																	
23	Switch between B and A+B																	
24	Pause PID	PID adjustment will be paused and inverter keeps output frequency unchanged.																
25	Pause operation	Pause operation make inverter decelerate to stop, preserve all of running parameters , inverter recover the running status as before after pause operation disappear.																
26	ACC/DEC ramp hold	Pauses acceleration or deceleration and maintains output frequency. When this terminal is disabled, acceleration/deceleration is restarted.																
27~29	Reserved	Reserved																
30	Available frequency running	Switch off status to variable frequency status of inverter by pulse signal of the terminals, if inverter is under other status, the terminals are invalid.																
31	Power frequency running	Switch off status to power frequency status of inverter by pulse signal of the terminals, if inverter is under other status, the terminals are invalid.																
32	Switching from variable frequency to power frequency.	Switch variable frequency status to power frequency status of inverter by pulse signal of the terminals, if inverter is under other status, the terminals are invalid.																
33	Switching from power frequency to variable	Switch power frequency status to variable frequency status of inverter by pulse signal of the terminals which is from high voltage control DCS, if inverter is under other status, the terminals are invalid.																

Setting value	Function	Description
	frequency.	Note:Function of 30~33 valid only for the inverter containing swiching cabinet, If not, they are invaild.
34	Emergency breaking input of high voltage	Send a signal by through the terminal 1 to cut off high voltage of inverter
35	Running command switch to keypad	If you input 1 signal to the terminals, running command switch to keypad whatever the command source is.
36	Running command switch to terminals	If you input 1 signal to the terminals, running command switch to terminals whatever the command source is.
37	Running command switch to communication	If you input 1 signal to the terminals, running command switch to remote host whatever the command source is.
38	Input signals of high voltage switching on.	Terminal with the function connect to feed back signals from up level switcher of high voltage. The inverter can detect current status of up level high voltage switcher
39	Reserved	Reserved

Function Code	Name	Description	Setting Range	Factory Setting
P5.16	Polar selection of input terminal	0x0000~0xFFFF	0x0000~0xFFFF	0x0000

Setting polar select of ON/OFF input terminals, each terminals take up one bit, 0: normal open, 1:normal close.

S16	S15	S14	S13	S12	S11	S10	S9	S8	S7	S6	S5	S4	S3	S2	S1
BIT1	BIT1	BIT1	BIT1	BIT1	BIT1	BIT9	BIT8	BIT7	BIT6	BIT5	BIT4	BIT3	BIT2	BIT1	BIT0
5	4	3	2	1	0										

Function Code	Name	Description	Setting Range	Factory Setting
P5.17	Filter time of ON/OFF	0~10	0~10	5

Set S1~S16 terminals filter time of sampling, increasing the parameter can rise anti-interference ability to prevent incorrect operation

Function Code	Name	Description	Setting Range	Factory Setting
P5.18	FWD/REV control mode	0~3	0~3	0

This parameter defines four different control modes that control the inverter operation through external terminals.

0: 2-wire control mode 1: Integrate START/STOP command with run direction.

K1	K2	Run command
OFF	OFF	Stop
ON	OFF	FWD
OFF	ON	REV
ON	ON	Stop

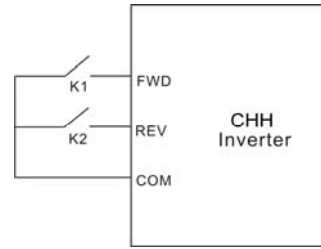

Figure 39 2-wire control mode 1.

1: 2-wire control mode 2: START/STOP command is determined by FWD terminal. Run direction is determined by REV terminal.

K1	K2	Run command
OFF	OFF	Stop
ON	OFF	FWD
OFF	ON	Stop
ON	ON	REV

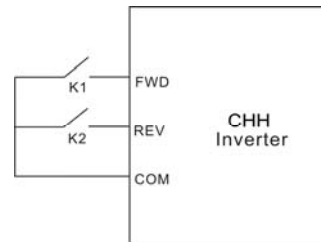

Figure 40 2-wire control mode 2.

2: 3-wire control mode 1: SB1: Start button. SB2: Stop button (NC), K: Run direction button, Terminal SIn is the multifunctional input terminal of S1~S8, HDI1 and HDI2. The terminal function should be set to be 3 (3-wire control).

K	Run command
OFF	Stop
ON	FWD

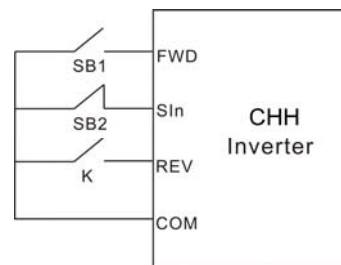

Figure 41 3-wire control mode 1.

3: 3-wire control mode 2:

SB1: Forward run button

SB2: Stop button (NC)

SB3: Reverse run button

Terminal SIn is the multifunctional input terminal of S1~S8, HDI1 and HDI2. The terminal function should be set to be 3 (3-wire control).

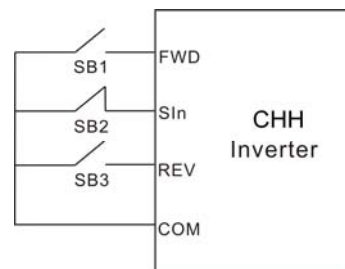

Figure 42 3-wire control mode 2.

Notice: When 2-wire control mode is active, the inverter will not run in following situation even if

FWD/REV terminal is enabled:

- Coast to stop (press **RUN** and **STOP/RST** at the same time).
- Stop command from serial communication.

FWD/REV terminal is enabled before power on. Please refer to description of P4.12

Function Code	Name	Description	Setting Range	Factory Setting
P5.19	UP setting change rate	0.01~50.00Hz/s	0.01~50.00	0.50 Hz/s
P5.20	DOWN setting change rate	0.01~50.00 Hz/s	0.01~50.00	0.50 Hz/s

This parameter is used to determine how fast UP/DOWN setting changes.

Function Code	Name	Description	Setting Range	Factory Setting
P5.21	AI1 lower limit	0.00~P5.23	0.00~P5.23	0.00V
P5.22	AI1 lower limit corresponding setting	-100.0~100.0	-100.0~100.0	0.0%
P5.23	AI1 upper limit	P5.21~10.00	P5.21~10.00	10.00V
P5.24	AI1 upper limit corresponding setting	-100.0~100.0	-100.0~100.0	100.0%
P5.25	AI1 filter time constant	0.00~10.00s	0.00~10.00s	0.10s

These parameters determine the relationship between analog input voltage and the corresponding setting value. When the analog input voltage exceeds the range between lower limit and upper limit, it will be regarded as the upper limit or lower limit.

The analog input AI1 can only provide voltage input, and the range is 0V~10V.

For different applications, the corresponding value of 100.0% analog setting is different. For details, please refer to description of each application.

Notice: AI1 lower limit must be less or equal to AI1 upper limit.

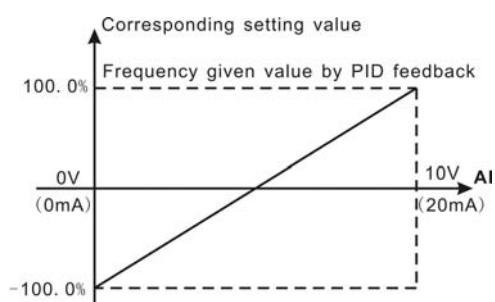

Figure 43 Relationship between AI and corresponding setting

Function Code	Name	Description	Setting Range	Factory Setting
P5.26	AI2 lower limit	0.00~P5.28	0.00~P5.28	0.00V
P5.27	AI2 lower limit corresponding setting	-100.0~100.0	-100.0~100.0	0.0%
P5.28	AI2 upper limit	P5.26~10.00	P5.26~10.00	5.00V

P5.29	AI2 upper limit corresponding setting	-100.0~100.0	-100.0~100.0	100.0%
P5.30	AI2 filter time constant	0.00~10.00s	0.00~10.00s	0.10s
P5.31	AI3 lower limit	-10.00~P5.33	-10.00~P5.33	-10.00V
P5.32	AI3 lower limit corresponding setting	-100.0~100.0	-100.0~100.0	0.0%
P5.33	AI3 upper limit	P5.31~10.00	P5.31~10.00	10.00V
P5.34	AI3 upper limit corresponding setting	-100.0~100.0	-100.0~100.0	100.0%
P5.35	AI3 filter time constant	0.00~10.00s	0.00~10.00s	0.10s

Please refer to description of AI1.

Notice: When AI2 is set as 0~20mA current input, the corresponding voltage range is 0~5V.

Function Code	Name	Description	Setting Range	Factory Setting
P5.36	HDI1 lower limit	0.000kHz~P5.38	0.000kHz~P5.38	0.000k
P5.37	HDI1 lower limit corresponding setting	-100.0~100.0	-100.0~100.0	0.0%
P5.38	HDI1 upper limit	P5.36~50.000kHz	P5.36~50.000kHz	50.000k
P5.39	HDI1 upper limit corresponding setting	-100.0~100.0	-100.0~100.0	100.0%
P5.40	HDI1 filter time constant	0.00~10.00	0.00~10.00	0.10s

The description of P5.36~P5.40 is similar to AI1.

P6 Group output terminals

CHH series have 8 multifunction Relay output terminals, 4 analog output terminals and 1 high speed pulse output terminal.

Function Code	Name	Description	Setting Range	Factory Setting
P6.00	Relay 1 output selection	0~20	0~20	0
P6.01	Relay 2 output selection	0~20	0~20	0
P6.02	Relay 3 output selection	0~20	0~20	0
P6.03	Relay 4 output selection	0~20	0~20	0
P6.04	Relay 5 output selection	0~20	0~20	0
P6.05	Relay 6 output selection	0~20	0~20	0
P6.06	Relay 7 output selection	0~20	0~20	0
P6.07	Relay 8 output	0~20	0~20	0

	selection		
--	-----------	--	--

Setting Value	Function	Description
0	No output	Output terminal has no function.
1	Run FOR/REV	ON: During forward/reverse run.
2	Fault output	ON: Inverter is in fault status.
3	FDT reached	Please refer to description of P3.15, P3.16.
4	Frequency reached	Please refer to description of P3.17.
5	Zero speed running	ON: The running frequency of inverter is zero.
6	Variable frequency	ON: inverter working in variable frequency status.
7	Power frequency	ON: inverter working in power frequency status.
8	Upper frequency limit reached	ON: Running frequency reaches the value of P0.08.
9	Lower frequency limit reached	ON: Running frequency reaches the value of P0.09.
10	Ready for running	ON: Inverter is ready (no fault, power is ON).
11	Ready for high voltage power on	ON: Pass self-testing, allow power on with high voltage
12	Alarm output	ON: Alarm(Not serious enough for error)
13	Status of KM1	ON; KM1 closed
14	Status of KM2	ON; KM2 closed
15	Status of KM3	ON; KM3 closed
16	Permission of high voltage switcher on	Inverter receive Variable frequency, it should pass self-testing and time of waiting for swithing on, and then send signals to up level(operation platform or high voltage switcher), The up level will switch on the high voltage switcher after the receiving.
17	Emergency breaking of high voltage	When inverter need to break with high voltage switcher ,send signals to up level t(operation platform or high voltage switcher) to break the high voltage switcher to protect inverter.

Notice:ON: Relay normal open switcher close, normal close switcher open

Function Code	Name	Description	Setting Range	Factory Setting
P6.08	HDO ON-OFF output selection	0~20	0~24	0
P6.09	AO1 output selection	0~20	0~24	0
P6.10	AO2 output selectio	0~20	0~24	0
P6.11	AO3 output selection	0~20	0~24	0
P6.12	AO4 output selection	0~20	0~24	0

Analog output terminal 1 and 2 have 0~10V voltage output, while Analog output terminal 3 and 4 can provide both 0~10V voltage and 0~20mA current signal, It is selectable by the jumper J3(AO3) and J4(AO4) on I/O the board.

0: High-speed pulse output: The maximum pulse frequency is 50.0 kHz. Please refer to description of P6.08.

AO/HDO output functions are indicated in the following table:

Setting Value	Function	Range
0	Running frequency	0~maximum frequency (P0.07)
1	Reference frequency	0~ maximum frequency (P0.07)
2	Inverter output current	0~2* inverter rated current
3	Motor current	0~2* motor rated current
4	Output voltage	0~2* inverter rated voltage
5	Output power	0~2* rated power
6	Output torque	0~2*rated torque
7	AI1 voltage	0~10V
8	AI2 voltage	0~10V
9	AI3 voltage	0~10V
10	Input line voltage of RS	0~1.5* rated voltage peak value
11	Input line voltage of ST	0~1.5* rated voltage peak value
12	Input line voltage of TR	0~1.5* rated voltage peak value
13	Output line voltage of AB	0~1.5* rated voltage peak value
14	Output line voltage of BC	0~1.5* rated voltage peak value
15	Output line voltage of CA	0~1.5* rated voltage peak value
16	Input current of R phase	0~1.5* rated Current peak value
17	Input current of S phase	0~1.5* rated Current peak value
18	Input current of T phase	0~1.5* rated Current peak value
19	Output current of A phase	0~1.5* rated Current peak value
20	Output current of B phase	0~1.5* rated Current peak value
21	Output current of C phase	0~1.5* rated Current peak value
22	A phase modulate waveform	Full voltage
23	B phase modulate waveform	Full voltage
24	C phase modulate waveform	Full voltage

Function Code	Name	Description	Setting Range	Factory Setting
P6.13	HDO lower limit	0.00%~P6.15	0.00%~P6.15	0.00%
P6.14	HDO lower limit corresponding output	0~50.000kHz	0~50.000kHz	0.000kHz
P6.15	HDO upper limit	P6.13~100.0%	P6.13~100.0%	100.0%
P6.16	HDO upper limit corresponding output	0~50.000kHz	0~50.000kHz	50.000kHz

These parameters determine the relationship between analog output voltage/current and the corresponding output value. When the high speed pulse output value exceeds the range between lower

limit and upper limit, it will output the upper limit or lower limit.

For different applications, the corresponding value of 100.0% high speed pulse output is different. For details, please refer to description of each application.

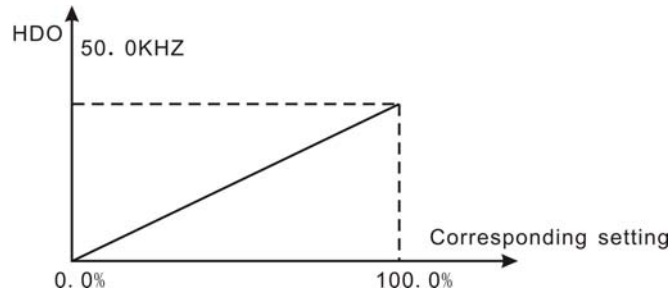

Figure 44 Relationship between HDO and corresponding setting.

Function Code	Name	Description	Setting Range	Factory Setting
P6.17	AO1 lower limit	0.0~P6.19	0.0~P6.19	0.00%
P6.18	AO1 lower limit corresponding output	0.00~10.00V	0.00~10.00V	0.00V
P6.19	AO1 upper limit	P6.17~100.0	P6.17~100.0	100.0%
P6.20	AO1 upper limit corresponding output	0.00~10.00V	0.00~10.00V	10.00V
P6.21	AO2 lower limit	0.00~P6.23	0.00~P6.23	0.00%
P6.22	AO2 lower limit corresponding output	0.00~10.00V	0.00~10.00V	0.00V
P6.23	AO2 upper limit	P6.21~100.0	P6.21~100.0	100.0%
P6.24	AO2 upper limit corresponding output	0.00~10.00V	0.00~10.00V	10.00V
P6.25	AO3 lower limit	0.0~P6.27	0.00~P6.27	0.00%
P6.26	AO3 lower limit corresponding output	0.00~10.00V	0.00~10.00V	0.00V
P6.27	AO3 upper limit	P6.25~100.0	P6.25~100.0	100.0%
P6.28	AO3 upper limit corresponding output	0.00~10.00V	0.00~10.00V	10.00V
P6.29	AO4 lower limit	0.00~P6.31	0.00~P6.31	0.00%
P6.30	AO4 lower limit corresponding output	0.00~10.00V	0.00~10.00V	0.00V
P6.31	AO4 upper limit	P6.29~100.0	P6.29~100.0	100.0%
P6.32	AO4 upper limit corresponding output	0.00~10.00V	0.00~10.00V	10.00V

The function is similar to HDO terminals

Notice: When AO is current output, 1mA is corresponding to 0.5V

For details, please refer to description of each application.

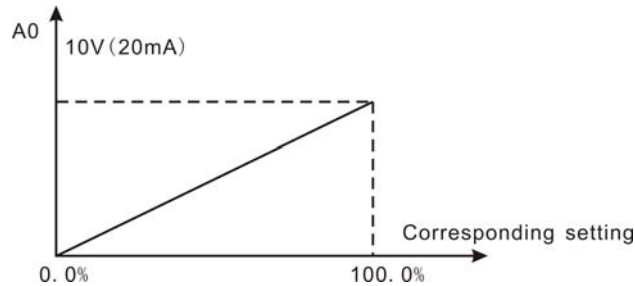

Figure 45 Relationship between AO and corresponding setting.

P7 Group Disply interface

Function Code	Name	Description	Setting Range	Factory Setting
P7.00	User password	0~65535	0~65535	0

The password protection function will be valid when set to be any nonzero data. When P7.00 is set to be 00000, user's password set before will be cleared and the password protection function will be disabled.

After the password has been set and becomes valid, the user can not access menu if the user's password is not correct. Only when a correct user's password is input, the user can see and modify the parameters. Please keep user's password in mind.

Function Code	Name	Description	Setting Range	Factory Setting
P7.01	LCD language selection	0:Chinese 1:ENGLISH(Reserved)	0~1	0

Function Code	Name	Description	Setting Range	Factory Setting
P7.02	Parameter copy	0: Invalid 1: Upload parameters to LCD 2: Download parameters from LCD	0~2	0

P7.02 will take effect when LCD keypad is used.

1: All value of parameters will be uploaded from inverter to LCD.

2: All value of parameters will be downloaded from LCD to inverter.

Notice: When upload or download operation completes, P7.02 will be set to 0 automatically.

Function Code	Name	Description	Setting Range	Factory Setting
P7.03	QUICK/JOG function selection	0: Quick debugging mode 1: FDW/REV switching 2: Jog	0~2	0

QUICK/JOG is a multifunctional key, whose function can be defined by the value of P7.03.

0: Quick debugging mode: Please refer to description of Chapter 5.

1: FWD/REV switching: Press **QUICK/JOG**, the running direction of inverter will reverse. It is only valid if P0.01 is set to be 0.

2: Jog: Press **QUICK/JOG**, the inverter will jog.

Function Code	Name	Description	Setting Range	Factory Setting
P7.04	STOP/RST function selection	0: Valid when keypad control (P0.01=0) 1: Valid when keypad or terminal control (P0.01=0 or 1) 2: Valid when keypad or communication control (P0.01=0 or 2) 3: Always valid	0~3	0

Notice:

- The value of P7.04 only determines the STOP function of **STOP/RST**.
- The RESET function of **STOP/RST** is always valid.

Function Code	Name	Description	Setting Range	Factory Setting
P7.05	Time setting	00.00~23.59	00.00~23.59	Real time

Function Code	Name	Description	Setting Range	Factory Setting
P7.06	Running status display selection1	0~0xFFFF	0~0xFFFF	0x0FFF
P7.07	Running status display selection2	0~0xFFFF	0~0xFFFF	0x0000

There are 26 status parameters of CHH inverter display on two Function code of P7.06 and P7.07, 16 general status displayed in P7.06 and the others are display on P7.07. for details, Please refer to function table as below.

If Bit is 0, the parameter will not be displayed; If Bit is 1, the parameter will be displayed. Press **» /SHIFT** to scroll through these parameters in right order .

The display content corresponding to each bit of P7.06 is described in the following table:

BIT15	BIT14	BIT13	BIT12	BIT11	BIT10
AI3	AI2	AI1 value	Output terminal status	Input terminal status	PID feed back
BIT9	BIT8	BIT7	BIT6	BIT5	BIT4
PID preset	Output torque	Output power	line speed	Rotation speed	Output current
BIT3	BIT2	BIT1	BIT0		
Output voltage	Input voltage	Frequency setting	Running frequency		

The display content corresponding to each bit of P7.07 is described in the following table(10 low bits of P7.07 available and high 6 bits reserved)

BIT15	BIT14	BIT13	BIT12	BIT11	BIT10
Reserved	Reserved	Reserved	Reserved	Reserved	Reserved
BIT9	BIT8	BIT7	BIT6	BIT5	BIT4
Inverter output	Inverter input	Time	Running time	Current percentage of inverter rated	Current percentage of

terminals status	terminals status			current	motor rated current
BIT3	BIT2	BIT1	BIT0		
Input current	Input power factor	Current steps of Multi-step	HDI frequency		

Notice:The input/output terminal status of bit11 and bit 12 in P7.06, bit8 and bit9 in P7.07 are displayed by decimal numbers,which convert to hexademical numbers with each bit represent the terminal ON/OFF status.

Example: decimal demical 10 convert to be 1010 of hexademical number, which mean bit2 and bit4 are on, the others is OFF, for details, please refer to P8.08 and P8.09

Function Code	Name	Description	Setting Range	Factory Setting
P7.08	Stop status display selection	0~0xFFFF	0~0xFFFF	0x0FFF

P7.08 determines the display parameters in stop status. The setting method is similar with P7.06 and P7.07.

The display content corresponding to each bit of P7.07 is described in the following table:

BIT15	BIT14	BIT13	BIT12	BIT11	BIT10	BIT9	BIT8
Reserved	Reserved	Inverter output terminals status	Inverter input terminals status	RTC Time	Current steps of multi-steps	HDI frequency	AI3
BIT7	BIT6	BIT5	BIT4	BIT3	BIT2	BIT1	BIT0
AI2	AI1	PID feedback	PID preset	Output terminal status	Input terminal status	Input voltage	Frequency setting

Function Code	Name	Description	Setting Range	Factory Setting
P7.09	Display coefficient of rotational speed	0.1~999.9%	0.1~999.9%	100.0%

Mechanical speed=120×P7.09/electric poles, it is used for regulating rotation speed display, have no effect to real speed.

Function Code	Name	Description	Setting Range	Factory Setting
P7.10	Display coefficient of rotational speed	0.1~999.9%	0.1~999.9%	1.0%

Line speed=mechanical speed×P7.10, it is used for regulating line speed display error, have no effect to real speed.

Function Code	Name	Description	Setting Range	Factory Setting
P7.11	DSP software version			
P7.12	Accumulated running time	0~65535h	0~65535h	

DSP Software version: Indicates current software version of DSP

Accumulated running time: Displays accumulated running time of inverter.

P8 Group fault record

CHH series inverter can recorder recent fault times and the runnig frequency, output curnet, BUS voltage information of last fault. Fault type, enviornment information is impermissible to modify, user can clean to be 0 of the fault information by P0.16.

Function Code	Name	Description	Setting Range	Factory Setting
P8.00	Last two fault types			
P8.01	Last time fault type			
P8.02	Type of current fault			

0: No Fault

There are two system fault and unit fault because of its structure.

Please refer to inverter fault code principle

EXX.YY, If XX=0, means system fault, If XX≠0, means unit fault and YY is fault code

For more details , Please refer to chapter 9.

Function Code	Name	Description	Setting Range	Factory Setting
P8.03	Running furquency of current fault			
P8.04	Ouptput current of current fault			
P8.05	DC bus voltage of current fault			
P8.06	DC bus voltage of current fault unit			
P8.07	Unit temperature of cunnent fault			
P8.08	Input terminal status of current fault			
P8.09	Output terminal status of current status			
P8.10	Time of current fault			

The status of current fault input terminals is a decimal number.

For all of digital input terminals status order during last fault. Please refer to table as below.

BIT15	BIT14	BIT13	BIT12	BIT11	BIT10	BIT9	BIT8
S16	S15	S14	S13	S12	S11	S10	S9
BIT7	BIT6	BIT5	BIT4	BIT3	BIT2	BIT1	BIT0
S8	S7	S6	S5	S4	S3	S2	S1

ON:1,OFF:0, it show digital input signal status during fault.

The status of current fault output terminals is a decimal number.

For all of digital output terminals status order during last fault.Please refer to table as below.

BIT15	BIT14	BIT13	BIT12	BIT11	BIT10	BIT9	BIT8
Reserved	Reserved	Reserved	Reserved	Reserved	Reserved	Reserved	Reserved
BIT7	BIT6	BIT5	BIT4	BIT3	BIT2	BIT1	BIT0
RO8	RO7	RO6	RO5	RO4	RO3	RO2	RO1

ON:1,OFF:0, it show digital output signal status during fault.

P8.06 and P8.07 is used to record fault unit status during fault

P9 Group PID Control

PID control is a common used method in process control, such as flow, pressure and temperature control. The principle is firstly detect the bias between preset value and feedback value, then calculate output frequency of inverter according to proportional gain, integral and differential time. Please refer to following figure.

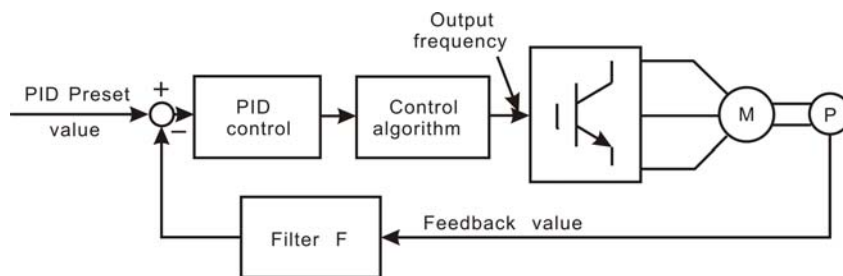

Figure 46 PID control diagram

Function Code	Name	Description	Setting Range	Factory Setting
P9.00	PID preset source selection	0: Keypad 1: AI1 2: AI2 3: AI3 4: AI1+AI2 5: AI2+AI3 6: AI1+AI3 7:HDI 8:Multi-step 9:Communication	0~9	0

These parameters are used to select PID preset and feedback source.

Notice:

- Preset value and feedback value of PID are percentage value.
- 100% of preset value is corresponding to 100% of feedback value.
- Preset source and feedback source must not be same, otherwise PID will be malfunction.

Function	Name	Description	Setting Range	Factory
----------	------	-------------	---------------	---------

Code				Setting
P9.01	Keypad PID preset	-100.0~100.0%	-100.0~100.0%	0.0%

Function Code	Name	Description	Setting Range	Factory Setting
P9.00	PID feedback source selection	0: AI1 1: AI2 2: AI3 3: AI1+AI2 4: AI2+AI3 5: AI1+AI3 6: HDI 7: Communication	0~7	0

Function Code	Name	Description	Setting Range	Factory Setting
P9.03	PID output characteristics	0: Positive 1: Negative	0~1	0

0: Positive. When the feedback value is greater than the preset value, output frequency will be decreased, such as tension control in winding application.

1: Negative. When the feedback value is greater than the preset value, output frequency will be increased, such as tension control in unwinding application.

Function Code	Name	Description	Setting Range	Factory Setting
P9.04	Proportional gain (Kp)	0.00~100.00	0.00~100.00	0.10
P9.05	Integral time (Ti)	0.01~10.00s	0.01~10.00s	0.10s
P9.06	Differential time (Td)	0.00~10.00s	0.00~10.00s	0.00s

Optimize the responsiveness by adjusting these parameters while driving an actual load.

Adjusting PID control:

Use the following procedure to activate PID control and then adjust it while monitoring the response.

1. Enabled PID control (P0.03=6)
2. Increase the proportional gain (Kp) as far as possible without creating oscillation.
1. Reduce the integral time (Ti) as far as possible without creating oscillation.
2. Increase the differential time (Td) as far as possible without creating oscillation.

Making fine adjustments:

First set the individual PID control constants, and then make fine adjustments.

- Reducing overshooting

If overshooting occurs, shorten the differential time and lengthen the integral time.

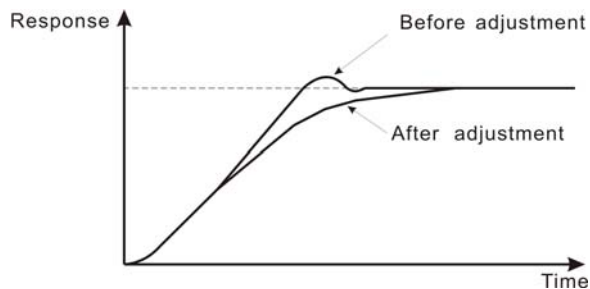

Figure 47 Reducing overshooting diagram.

- Rapidly stabilizing control status

To rapidly stabilize the control conditions even when overshooting occurs, shorten the integral time and lengthen the differential time.

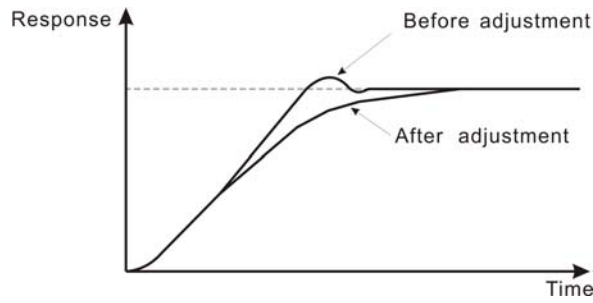

Figure 48 Rapidly stabilizing diagram.

- Reducing long-cycle oscillation

If oscillation occurs with a longer cycle than the integral time setting, it means that integral operation is strong. The oscillation will be reduced as the integral time is lengthened.

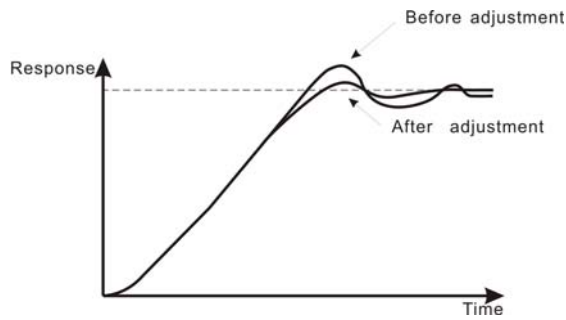

Figure 49 Reducing long-cycle oscillation diagram.

- Reducing short-cycle oscillation

If the oscillation cycle is short and oscillation occurs with a cycle approximately the same as the differential time setting, it means that the differential operation is strong. The oscillation will be reduced as the differential time is shortened.

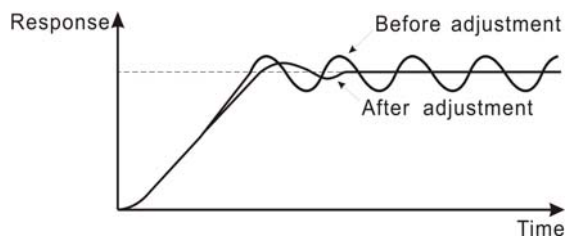

Figure 50 Reducing short-cycle oscillation diagram.

If oscillation cannot be reduced even by setting the differential time to 0, then either lower the proportional gain or raise the PID primary delay time constant.

Function Code	Name	Description	Setting Range	Factory Setting
P9.07	Sampling cycle (T)	0.01~100.00s	0.01~100.00s	0.50s
P9.08	Bias limit	0.0~100.0%	0.0~100.0%	0.0%

Sampling cycle T refers to the sampling cycle of feedback value. The PI regulator calculates once in each sampling cycle. The bigger the sampling cycle, the slower the response is.

Bias limit defines the maximum bias between the feedback and the preset. PID stops operation when the bias is within this range. Setting this parameter correctly is helpful to improve the system output accuracy and stability.

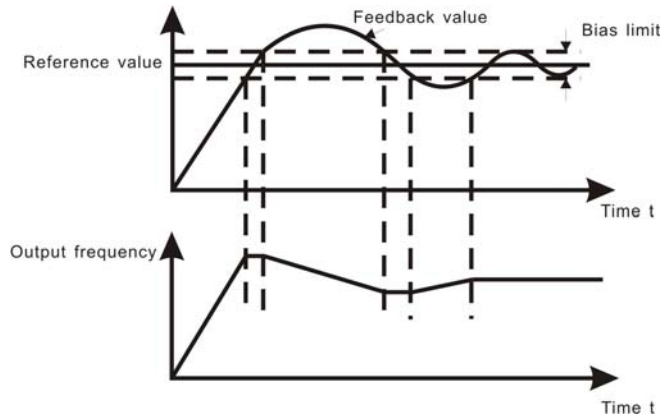

Figure 51 Relationship between bias limit and output frequency.

Function Code	Name	Description	Setting Range	Factory Setting
P9.09	Feedback lost detecting value	0.0~100.0%	0.0~100.0%	0.0%
P9.10	Feedback lost detecting time	0.0~3600.0s	0.0~3600.0s	1.0s

When feedback value is less than P9.10 continuously for the period determined by P9.11, the inverter will alarm feedback lost failure (E00.17).

Notice: 100% of P9.10 is the same as 100% of P9.01.

Function Code	Name	Description	Setting Range	Factory Setting
P9.11	PID dormancy wake up value	0.0~100.0%	0.0~100.0%	0.0%
P9.12	PID dormancy delay time	0.0~3600.0s	0.0~3600.0s	0.0s

PID dormancy wake up value:IF PID feed back≠ dormancy value, PID will be wake up, then inverter frequency increase from 0 until PID feed back reach PID preset again.

PID dormancy delay time:If not 0. PID dormancy valid, PID feedback reach PID preset and work steadily,inverter will work in current status for PID dormancy delay time, and then reduce frequency to 0 according to preset entering dormancy status until PID dormancy wake up.

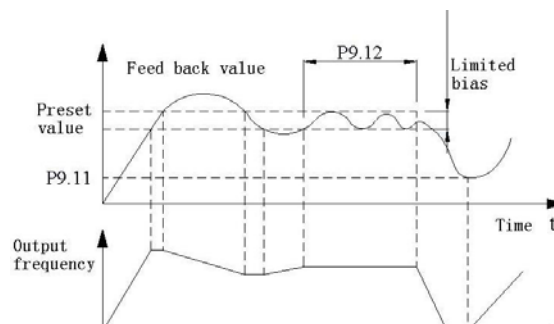

Figure 52 Diagram of dormancy and dormancy wake up

Frequency increase after inverter start,PID feed back increase too. When the feed back reach

preset value, inverter maintain current status and PID walk into dormancy delay time(Constant output frequency, keep PID within bias limit), inverter frequency reduce to 0 in the decrease time, because of system inertia, PID feed back reduce slowly. When feed back value reach wake up value,inverter wakeup from dormancy status, frequency increase,PID feedback increase too.

PA Group Multi-steps control

Function Code	Name	Description	Setting Range	Factory Setting
PA.00	Multi-step speed 0	-100.0~100.0%	-100.0~100.0%	0.0%
PA.01	Multi-step speed 1	-100.0~100.0%	-100.0~100.0%	0.0%
PA.02	Multi-step speed 2	-100.0~100.0%	-100.0~100.0%	0.0%
PA.03	Multi-step speed 3	-100.0~100.0%	-100.0~100.0%	0.0%
PA.04	Multi-step speed 4	-100.0~100.0%	-100.0~100.0%	0.0%
PA.05	Multi-step speed 5	-100.0~100.0%	-100.0~100.0%	0.0%
PA.06	Multi-step speed 6	-100.0~100.0%	-100.0~100.0%	0.0%
PA.07	Multi-step speed 7	-100.0~100.0%	-100.0~100.0%	0.0%
PA.08	Multi-step speed 8	-100.0~100.0%	-100.0~100.0%	0.0%
PA.09	Multi-step speed 9	-100.0~100.0%	-100.0~100.0%	0.0%
PA.10	Multi-step speed 10	-100.0~100.0%	-100.0~100.0%	0.0%
PA.11	Multi-step speed 11	-100.0~100.0%	-100.0~100.0%	0.0%
PA.12	Multi-step speed 12	-100.0~100.0%	-100.0~100.0%	0.0%
PA.13	Multi-step speed 13	-100.0~100.0%	-100.0~100.0%	0.0%
PA.14	Multi-step speed 14	-100.0~100.0%	-100.0~100.0%	0.0%
PA.15	Multi-step speed 15	-100.0~100.0%	-100.0~100.0%	0.0%

Notice:

- 100% of multi-step speed x corresponds to the maximum frequency (P0.07).
- If the value of multi-step speed x is negative, the direction of this step will be reverse, otherwise it will be forward.

Selection of step is determined by combination of multi-step terminals. Please refer to following figure and table.

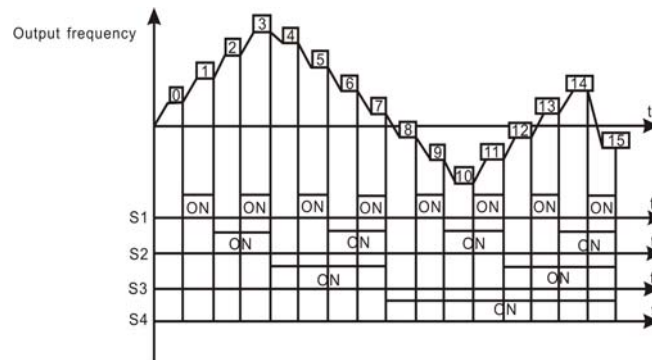

Figure 53 Multi-steps speed operation diagram

Set S1~S4 as multi-steps input terminals, S1=S2=S3=S4=OFF, Frequency source is determined by P0.03~P0.06. If not all of S1,S2,S3,S4 are OFF, Multi-steps works, It is more priority than Keypad,

analog input, High speed pulse input, communication .16 steps is combined by S1,S2,S3,S4 code.

S1	OFF	ON	OFF	ON	OFF	ON	OFF	ON	OFF	ON	OFF	ON	OFF	ON	OFF	ON
S2	OFF	OFF	ON	ON	OFF	OFF	ON	ON	OFF	OFF	ON	ON	OFF	OFF	ON	ON
S3	OFF	OFF	OFF	OFF	ON	ON	ON	ON	OFF	OFF	OFF	OFF	ON	ON	ON	ON
S4	OFF	OFF	OFF	OFF	OFF	OFF	OFF	OFF	ON	ON	ON	ON	ON	ON	ON	ON
段	0	1	2	3	4	5	6	7	8	9	10	11	12	13	14	15

PB Group Protection Parameter

Function Code	Name	Description	Setting Range	Factory Setting
Pb.00	Reserved	Reserved	Reserved	
Pb.01	Output phase-failure protection	0: Disabled 1: Enabled	0~1	1

Notice: Please be cautious to set these parameters as disabled. Otherwise it may cause inverter and motor overheat even damaged.

Function Code	Name	Description	Setting Range	Factory Setting
Pb.02	Motor overload protection	0: Disabled 1: Normal motor 2: Variable frequency motor	0~2	2

1: For normal motor, the lower the speed, the poorer the cooling effect. Based on this reason, if output frequency is lower than 30Hz, inverter will reduce the motor overload protection threshold to prevent normal motor from overheat.

2: As the cooling effect of variable frequency motor has nothing to do with running speed, it is not required to adjust the motor overload protection threshold.

Function Code	Name	Description	Setting Range	Factory Setting
Pb.03	Motor overload protection current	20.0~120.0%	20.0~120.0%	100.0%

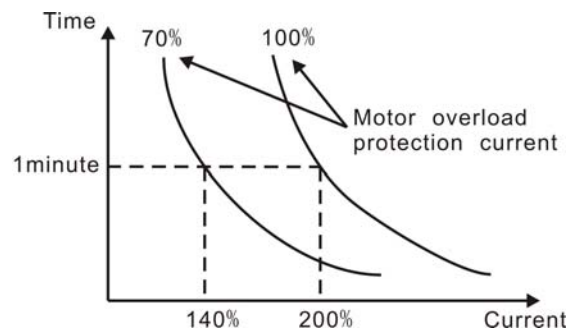

Figure 54 Motor overload protection curve

The value can be determined by the following formula:

$$\text{Motor overload protection current} = (\text{motor rated current} / \text{inverter rated current}) * 100\%$$

Notice:

- This parameter is normally used when rated power of inverter is greater than rated power of motor.
- Motor overload protection time: 60s with 200% of rated current. For details, please refer to above figure.

Function Code	Name	Description	Setting Range	Factory Setting
Pb.04	Threshold of trip-free	70.0~110.0%	70.0~110.0%	80.0%
Pb.05	Decrease rate of trip-free	0.00~P0.07	0.00~P0.07	0.00Hz

If PB.05 is set to be 0, the trip-free function is invalid.

Trip-free function enables the inverter to perform low-voltage compensation when DC bus voltage drops below PB.04. The inverter can continue to run without tripping by reducing its output frequency and feedback energy via motor.

Notice: If PB.05 is too big, the feedback energy of motor will be too large and may cause over-voltage fault. If PB.05 is too small, the feedback energy of motor will be too small to achieve voltage compensation effect. So please set PB.05 according to load inertia and the actual load.

Function Code	Name	Description	Setting Range	Factory Setting
Pb.06	Over-voltage stall protection	0: Disabled 1: Enabled	0~1	0
Pb.07	Over-voltage stall protection point	105~140%	105~140%	120%

During deceleration, the motor's decelerating rate may be lower than that of inverter's output frequency due to the load inertia. At this time, the motor will feed the energy back to the inverter, resulting in DC bus voltage rise. If no measures taken, the inverter will trip due to over voltage.

During deceleration, the inverter detects DC bus voltage and compares it with over-voltage stall protection point. If DC bus voltage exceeds PB.07, the inverter will stop reducing its output frequency. When DC bus voltage become lower than PB.10, the deceleration continues, as shown in following figure.

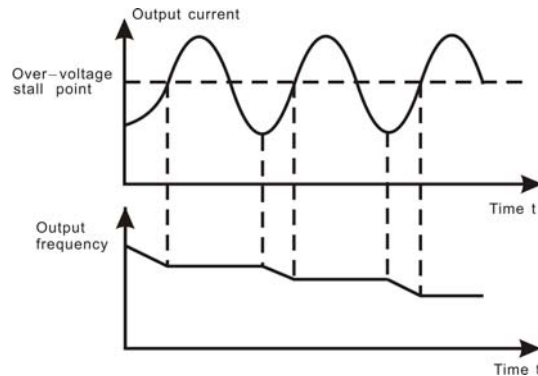

Figure 55 Over-voltage stall function

Function Code	Name	Description	Setting Range	Factory Setting
Pb.08	Over-current protection	0: Disabled 1: Enabled	0~1	0
Pb.09	Over-current stall threshold	50~200%	50~200%	120%

During acceleration of inverter, the actual motor speed rise rate may lower than the output frequency rise rate because of too big load. If no measures to take, inverter will trip caused by over-current.

The principle of over-current protection is to detect the output current of inverter during inverter operation and compare it with over-current stall threshold determined by PB.09. If it exceeds the value of PB.09 during acceleration, inverter will remain output frequency; if it exceeds the value of PB.09 during constant speed running, inverter will decrease output frequency. When output current of inverter is lower than the value of PB.09, inverter will continue to accelerate until output frequency reach frequency reference. Please refer to following diagram.

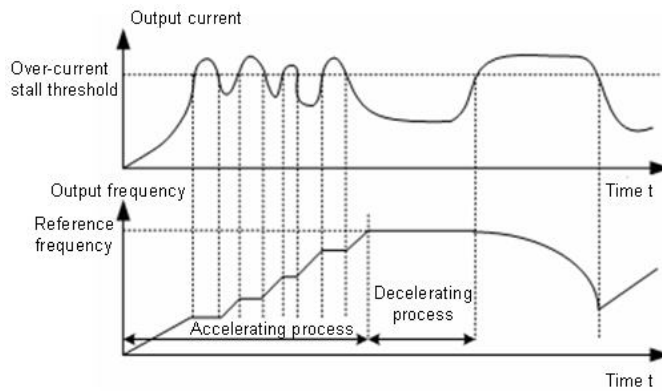

Figure 56 Over-current stall function

Function Code	Name	Description	Setting Range	Factory Setting
Pb.10	Input overvoltage pre-warning threshold	105~125%	105~125%	110%

Pb.10 is set input voltage pre-warning threshold, when real input voltage exceed the point, inverter warning, It's setting is corresponding to percentage of input rated voltage

Function Code	Name	Description	Setting Range	Factory Setting
Pb.11	Unit bypass function	0: Manual bypass 1:Auto bypass	0~1	0
Pb.12	Unit manual bypass bit selection	0x000~0x1FF	0x000~0x1FF	0x000

Pb.11 is used to set inverter bypass function.

0:manual bypass,unit failure, inverter stoped and indicate error,If user want bypass failure unit, it's necessary to set Pb.12 to bypass failure unit after stopping.

1:Auto bypass,unit failure, inverter do not stop and bypass failure unit automaticly. Pb.12 is invalid. CHH series high voltage inverter Supporting a maximum of 9 units in series, each bit of Pb.12 corresponding to unit number in series. Pb.12 indicate as hexademical, each bit corresponding to one unit. If bit=1, No bypass,If bit=0, means bypass the unit.

Function Code	Name	Description	Setting Range	Factory Setting
Pb.13	hardware overcurrnet threshold	50~200%	50~200%	150%
Pb.14	Power frequency bypass when failure	0:manual power frequency bypass 1:Auto power frequency bypass	0~1	0

Inverter switch to power frequency when failure.

0:manual bypass:Inverter failure, system choose coast to stop or cut off high voltage input when coast to stop according to seriousness.

1:Auto bypass: Coast to stop and switch to power frequency when inverter error.

PC Group Serial Communication

Function Code	Name	Description	Setting Range	Factory Setting
PC.00	Local address	1~247	1~247	1

This parameter determines the slave address used for communication with master. The value "0" is the broadcast address.

Function Code	Name	Description	Setting Range	Factory Setting
PC.01	Baud rate selection	0: 1200BPS 1: 2400BPS 2: 4800BPS 3: 9600BPS 4: 19200BPS 5: 38400BPS	0~5	4

This parameter can set the data transmission rate during serial communication.

Notice: The baud rate of master and slave must be the same.

Function Code	Name	Description	Setting Range	Factory Setting
PC.02	Data format	0~5	0~5	1

This parameter defines the data format used in serial communication protocol.

- 0: RTU, 1 start bit, 8 data bits, no parity check, 1 stop bit.
- 1: RTU, 1 start bit, 8 data bits, even parity check, 1 stop bit.
- 2: RTU, 1 start bit, 8 data bits, odd parity check, 1 stop bit.
- 3: RTU, 1 start bit, 8 data bits, no parity check, 2 stop bits.
- 4: RTU, 1 start bit, 8 data bits, even parity check, 2 stop bits.
- 5: RTU, 1 start bit, 8 data bits, odd parity check, 2 stop bits.
- 6: ASCII, 1 start bit, 7 data bits, no parity check, 1 stop bit.
- 7: ASCII, 1 start bit, 7 data bits, even parity check, 1 stop bit.
- 8: ASCII, 1 start bit, 7 data bits, odd parity check, 1 stop bit.
- 9: ASCII, 1 start bit, 7 data bits, no parity check, 2 stop bits.
- 10: ASCII, 1 start bit, 7 data bits, even parity check, 2 stop bits.
- 11: ASCII, 1 start bit, 7 data bits, odd parity check, 2 stop bits.
- 12: ASCII, 1 start bit, 8 data bits, no parity check, 1 stop bit.
- 13: ASCII, 1 start bit, 8 data bits, even parity check, 1 stop bit.
- 14: ASCII, 1 start bit, 8 data bits, odd parity check, 1 stop bit.
- 15: ASCII, 1 start bit, 8 data bits, no parity check, 2 stop bits.
- 16: ASCII, 1 start bit, 8 data bits, even parity check, 2 stop bits.
- 17: ASCII, 1 start bit, 8 data bits, odd parity check, 2 stop bits.

Function Code	Name	Description	Setting Range	Factory Setting
PC.03	Communication delay time	0~200ms	0~200ms	200

This parameter can be used to set the response delay in communication in

order to adapt to the MODBUS master. In RTU mode, the actual communication delay

Function Code	Name	Description	Setting Range	Factory Setting
PC.04	Communication timeout delay	0.0~100s	0.0~100s	0.0s

When the value is zero, this function will be disabled. When communication interruption is longer than the non-zero value of PC.04, the inverter will alarm communication error (E00.13).

Function Code	Name	Description	Setting Range	Factory Setting
PC.05	Communication error action	0: Alarm and coast to stop 1: No alarm and continue to run 2: No alarm but stop according to P1.06 (if P0.03=2) 3: No alarm but stop according to P1.06	0~3	1

0: When communication error occurs, inverter will alarm (CE) and coast to stop.

1: When communication error occurs, inverter will omit the error and continue to run.

2: When communication error occurs, if P0.03=2, inverter will not alarm but stop according to stop mode determined by P1.06. Otherwise it will omit the error.

3: When communication error occurs, inverter will not alarm but stop according to stop mode determined by P1.06.

Function Code	Name	Description	Setting Range	Factory Setting
PC.06	Response action	Unit's place of LED 0: Response to writing 1: No response to writing Ten's place of LED 0: Reference not saved when power off 1: Reference saved when power off	0x000~0x111	0x000

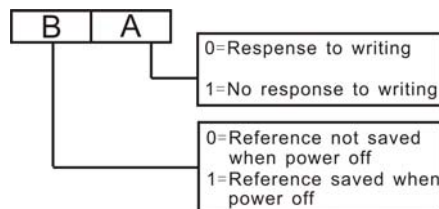

Figure 57 Meaning of PC.06.

A stands for: Unit's place of LED.

B stands for: Ten's place of LED

PD Group unit status query function

CHH series inverter can query power unit temperature, DC bus voltage, warning ect, it's more accurate to know the status of power unit.

Function Code	Name	Description	Setting Range	Factory Setting
PD.00	A-Phase unit indication	0x000~0x1FF	0x000~0x1FF	电压确定
PD.01	B-phase unit indication	0x000~0x1FF	0x000~0x1FF	电压确定
PD.02	C-phase unit indication	0x000~0x1FF	0x000~0x1FF	电压确定

The error of power unit can be neglected of each phase(A,B,C),It is indicated inPD.00~PD.02

CHH series high voltage inverter support maximum 9 power units in series, the function of low 9 bits relative to each phase power unit, the function defined by hexadecimal.

If the bit =1, the corresponding power unit error is not neglected, If the bit=0, means power unit error can be neglected.

Notice:

The function is only used to neglect warning during power unit error, the power unit error fault information can be queried by fault inquiry function.

Function Code	Name	Description	Setting Range	Factory Setting
PD.03	Unit A1 temperature indication	0.0~100.0℃	0.0~100.0℃	
PD.04	Unit A2 temperature indication	0.0~100.0℃	0.0~100.0℃	
PD.05	Unit A3 temperature indication	0.0~100.0℃	0.0~100.0℃	
PD.06	Unit A4 temperature indication	0.0~100.0℃	0.0~100.0℃	
PD.07	Unit A5 temperature indication	0.0~100.0℃	0.0~100.0℃	
PD.08	Unit A6 temperature indication	0.0~100.0℃	0.0~100.0℃	
PD.09	Unit A7 temperature indication	0.0~100.0℃	0.0~100.0℃	
PD.10	Unit A8 temperature indication	0.0~100.0℃	0.0~100.0℃	
PD.11	Unit A9 temperature indication	0.0~100.0℃	0.0~100.0℃	
PD.12	Unit B1 temperature indication	0.0~100.0℃	0.0~100.0℃	
PD.13	Unit B2 temperature indication	0.0~100.0℃	0.0~100.0℃	
PD.14	Unit B3 temperature indication	0.0~100.0℃	0.0~100.0℃	
PD.15	Unit B4 temperature indication	0.0~100.0℃	0.0~100.0℃	
PD.16	Unit B5 temperature indication	0.0~100.0℃	0.0~100.0℃	
PD.17	Unit B6 temperature indication	0.0~100.0℃	0.0~100.0℃	
PD.18	Unit B7 temperature indication	0.0~100.0℃	0.0~100.0℃	
PD.19	Unit B8 temperature indication	0.0~100.0℃	0.0~100.0℃	
PD.20	Unit B9 temperature indication	0.0~100.0℃	0.0~100.0℃	

PD.21	Unit C1 temperature indication	0.0~100.0℃	0.0~100.0℃	
PD.22	Unit C2 temperature indication	0.0~100.0℃	0.0~100.0℃	
PD.23	Unit C3 temperature indication	0.0~100.0℃	0.0~100.0℃	
PD.24	Unit C4 temperature indication	0.0~100.0℃	0.0~100.0℃	
PD.25	Unit C5 temperature indication	0.0~100.0℃	0.0~100.0℃	
PD.26	Unit C6 temperature indication	0.0~100.0℃	0.0~100.0℃	
PD.27	Unit C7 temperature indication	0.0~100.0℃	0.0~100.0℃	
PD.28	Unit C8 temperature indication	0.0~100.0℃	0.0~100.0℃	
PD.29	Unit C9 temperature indication	0.0~100.0℃	0.0~100.0℃	

Notice: All of informaiton is read only.

Function Code	Name	Description	Setting Range	Factory Setting
PD.30	Unit A1 DC bus voltage indication	0~2000V	0~2000V	
PD.31	Unit A2 DC bus voltage indication	0~2000V	0~2000V	
PD.32	Unit A3 DC bus voltage indication	0~2000V	0~2000V	
PD.33	Unit A4 DC bus voltage indication	0~2000V	0~2000V	
PD.34	Unit A5 DC bus voltage indication	0~2000V	0~2000V	
PD.35	Unit A6 DC bus voltage indication	0~2000V	0~2000V	
PD.36	Unit A7 DC bus voltage indication	0~2000V	0~2000V	
PD.37	Unit A8 DC bus voltage indication	0~2000V	0~2000V	
PD.38	Unit A9 DC bus voltage indication	0~2000V	0~2000V	
PD.39	Unit B1 DC bus voltage indication	0~2000V	0~2000V	
PD.40	Unit B2 DC bus voltage indication	0~2000V	0~2000V	
PD.41	Unit B3 DC bus voltage indication	0~2000V	0~2000V	
PD.42	Unit B4 DC bus voltage indication	0~2000V	0~2000V	
PD.43	Unit B5 DC bus voltage indication	0~2000V	0~2000V	
PD.44	Unit B6 DC bus voltage indication	0~2000V	0~2000V	
PD.45	Unit B7 DC bus voltage indication	0~2000V	0~2000V	
PD.46	Unit B8 DC bus voltage indication	0~2000V	0~2000V	

PD.47	Unit B9 DC bus voltage indication	0~2000V	0~2000V	
PD.48	Unit C1 DC bus voltage indication	0~2000V	0~2000V	
PD.49	Unit C2 DC bus voltage indication	0~2000V	0~2000V	
PD.50	Unit C3 DC bus voltage indication	0~2000V	0~2000V	
PD.51	Unit C4 DC bus voltage indication	0~2000V	0~2000V	
PD.52	Unit C5 DC bus voltage indication	0~2000V	0~2000V	
PD.53	Unit C6 DC bus voltage indication	0~2000V	0~2000V	
PD.54	Unit C7 DC bus voltage indication	0~2000V	0~2000V	
PD.55	Unit C8 DC bus voltage indication	0~2000V	0~2000V	
PD.56	Unit C9 DC bus voltage indication	0~2000V	0~2000V	

Notice: All of informaiton mentioned in table above is read only

Function Code	Name	Description	Setting Range	Factory Setting
PD.57	Unit A1 fault indicated value	0~0xFFFF	0~0xFFFF	
aPD.58	Unit A2 fault indicated value	0~0xFFFF	0~0xFFFF	
PD.59	Unit A3 fault indicated value	0~0xFFFF	0~0xFFFF	
PD.60	Unit A4 fault indicated value	0~0xFFFF	0~0xFFFF	
PD.61	Unit A5 fault indicated value	0~0xFFFF	0~0xFFFF	
PD.62	Unit A6 fault indicated value	0~0xFFFF	0~0xFFFF	
PD.63	Unit A7 fault indicated value	0~0xFFFF	0~0xFFFF	
PD.64	Unit A8 fault indicated value	0~0xFFFF	0~0xFFFF	
PD.65	Unit A9 fault indicated value	0~0xFFFF	0~0xFFFF	
PD.66	Unit B1 fault indicated value	0~0xFFFF	0~0xFFFF	
PD.67	Unit B2 fault indicated value	0~0xFFFF	0~0xFFFF	
PD.68	Unit B3 fault indicated value	0~0xFFFF	0~0xFFFF	
PD.69	Unit B4 fault indicated value	0~0xFFFF	0~0xFFFF	
PD.70	Unit B5 fault indicated value	0~0xFFFF	0~0xFFFF	
PD.71	Unit B6 fault indicated value	0~0xFFFF	0~0xFFFF	
PD.72	Unit B7 fault indicated value	0~0xFFFF	0~0xFFFF	
PD.73	Unit B8 fault indicated value	0~0xFFFF	0~0xFFFF	
PD.74	Unit B9 fault indicated value	0~0xFFFF	0~0xFFFF	
PD.75	Unit C1 fault indicated value	0~0xFFFF	0~0xFFFF	
PD.76	Unit C2 fault indicated value	0~0xFFFF	0~0xFFFF	
PD.77	Unit C3 fault	0~0xFFFF	0~0xFFFF	

	indicated value			
PD.78	Unit C4 fault indicated value	0~0xFFFF	0~0xFFFF	
PD.79	Unit C5 fault indicated value	0~0xFFFF	0~0xFFFF	
PD.80	Unit C6 fault indicated value	0~0xFFFF	0~0xFFFF	
PD.81	Unit C7 fault indicated value	0~0xFFFF	0~0xFFFF	
PD.82	Unit C8 fault indicated value	0~0xFFFF	0~0xFFFF	
PD.83	Unit C9 fault indicated value	0~0xFFFF	0~0xFFFF	

Notice: All of information mentioned in table above is read only

PE Group Factory Setting

This group is the factory-set parameter group. It is prohibited for user to access.

Chapter 9 Warning information and fault solution

CHH series high voltage inverter have perfect protection and alarm function,when inverter is error,Inverter indicate fault status and implement stopping protection, power unit bypass, acousto-optic alarm, cut off high voltage input automaticly according to alarm level.

CHH series high volatge have two kinds fault, 1:unit fault 2: system fault, express as EX1X2.Y1Y2, X1X2 means system fault or unit fault. Y1Y2 is fault code.

X1X2=00, system fault, Y1Y2 is system fault code

Unit fault,X1 means fault the phase of unit. X2:The unit in the location of fault phase, Y1Y2:first fault code of error unit.

CHH series high voltage inverter provide alarm function. When inverter have abnormal status but not serious enough to damage. The inverter cause acousto-optic alarm and not stop during alarm time. Inverter can auto reset or manual reset when alarm. There are two type alarm of CHH series high voltage inverter, Unit alarm and system alarm, It is express as AX1X2.Y1Y2,

X1X2:Alarm unit

Y1Y2:Alarm code

X1X2=00,system fault

Y1Y2:system fault code

For Unit fault,X1 means fault phase, X2 means The unit in the location of fault phase, Y1Y2:first fault code of error unit.

9.1 Fault and trouble shooting

Fault Code	Fault Type	Reason	Solution
E00.01	Over-current when acceleration	1.Acc time is too short. 2.The voltage of Grid is tool low 3.Inverter rated power is too small	1.Increase Acc time 2.Check input poower supply 3.Select bigger power range inverter
E00.02	Over-current when deceleration	1.Dec time is too short 2.Load inertia torque is too large 3.Inverter rated power is too small	1. Increase Dec time 2.Select bigger power range inverter
E00.03	Over-current when constant speed running	1.Load sudden change or abnormal 2.Voltage of Grid is to low 3.Inverter rated power is too small	1.Check load or reduce load sudden change 2.Check input poower supply 3.Select bigger power range inverter
E00.04	Over-voltage when acceleration	1.Input voltage abnormal 2.sudden cut off power, rotation motor restart	1.Check input power supply 2.Avoid stop and restart
E00.05	Over-voltage when deceleration	1.Dec time is too short 2.Load inertia torque is too large 3.Input voltage abnormal	1. Increase Dec time 2.Check input power supply
E00.06	Over-voltage when	1.Input voltage variation abnormal	1.Select bigger power range

	constant speed running	2.Load inertia too large	inverter
E00.07	Grid under-voltage	Grid voltage is too low	1.Check the power supply of Grid
E00.08	Motor overload	1. Motor drive heavy load at low speed for a long time. 2. Improper V/F curve 3. Improper motor's overload protection threshold (PB.03) 4. Sudden change of load.	1. Select variable frequency motor. 2. Check and adjust V/F curve. 3. Check and adjust PB.03 4. Check the load.
E00.09	Inverter overload	1. Load is too heavy or Acc/Dec time is too short. 2. Improper V/F curve 3. Capacity of inverter is too small.	1. Increase Acc/Dec time or select bigger capacity inverter. 2. Check and adjust V/F curve. 3. Select bigger capacity inverter.
E00.10	Output phase failure	1. There is a broken wire in the output cable 2. There is a broken wire in the motor winding. 3. Output terminals are loose.	Check the wiring and installation.
E00.11	phase shifting transformer over heating	1.Over load 2.Enviroment temperature is too high 3.Tempearture controller fault 4. Transformer cooling fault 5.Interfece of protection circuit 6. Control cable shiled layer is not grounding	1.check external signal cable and shield layer ground right or not 2.Check transformer load and enviroment temperature compare to rated value. 3. check install condition 4. check control cable shield layer grounding right or not 6.Check temperature controller and its circuit.
E00.12	External fault	Sx: External fault input terminal take effect.	Inspect external equipment.
E00.13	Communication fault	1. Improper baud rate setting. 2. Receive wrong data. 3. Communication is interrupted for Long time	1. Set proper baud rate. 2. Check communication devices and signals.
E00.14	Current detection fault	1. Wires or connectors of control board are loose 2. Hall sensor is damaged. 3. Amplifying circuit is abnormal.	1. Check the wiring. 2. Ask for support.
E00.15	Autotuning fault	Reserved	Reserved
E00.16	EEPROM fault	Read/Write fault of control parameters	Press STOP/RESET to reset Ask for support
E00.17	PID feedback fault	1. PID feedback disconnected. 2. PID feedback source disappears.	1. Inspect PID feedback signal wire. 2. Inspect PID feedback source.
E00.18	Clock chip fault	Clock chip damaged	Ask for support.
E00.19	Output grounding fault	1.output cable or motor have snigle phase grounding	1.Check external cable and motor grounding or not 2. Use M OHM meter checking the insulation of motor and motor cable
E00.20	Cabinet door switcher fault	1.Cabinet door open 2.Cabinet door switcher error 3.Control cable shield is not grounding.	Check the cabinet door status, Check the switcher and touch point of cabinet door.
E00.21	Grid overvoltage	Grid voltage is 20% higher than rated voltage	Decrease input Grid voltage

9.2 Unit fault

CHH high voltage allow unit report all of current fault. There are 12 bits, each bit corresponding to one type fault, inverter will report the fault according to their way of EX1X2.Y1Y2 when unit fault without the fault shield, Fault unit X1X2 means the first unit with error. Fault code Y1Y2 is corresponding to first fault unit's fault bit

All of fault information can be found with function code PD.57~PD.83

Refer to relationship between fault bit and fault type.

Fault bit	Fault Name	Reason	Solution
1	Unit optical fiber uplink communication	1. Tie-in loose 2. broken 3. Unit fault	1. re-plugin tie-in 2. replace optical fiber 3. ask for service
2	Unit optical fiber downlink communication	1. Tie-in loose 2. broken	1. re-plugin tie-in 2. replace optical 3. ask for service
3	Unit is not ready	control board of unit fault	1. replace fault unit 2. ask for service
4	Unit over voltage	1. Big inertia of load, decrease too fast 2. Current vibration 3. Grid voltage is too high 4. unit error	1. set longer decrease time 2. reduce input voltage 3. Ask for service
5	unit under-voltage	1. Grid voltage is too low	1. Check grid voltage
6	Unit power supply fault	1. unit drive board fault 2. unit power board fault	1. Ask for service
7	Unit overheating	1. environment temperature is too high 2. Unit cooling channel is not clear 3. cabinet tightness and cooling condition are not good,	1. Reduce environment temperature 2. Ask for service 3. Clear dusty of filter
8	Unit input phase lacking	1. Unit input terminals wiring error 2. Phase-shifting transformer fault 3. Unit fuse broken	1. Check and reconnect the input wire 2. Ask for service
9	Unit power fall	1. Unit input terminals wiring error 2. unit fault	1. Check and reconnect the input wire 2. Ask for service
10	reserved	reserved	reserved
11	VCE fault	1. Unit output shortcircuit 2. H bridge direct connection 3. Unit drive error	1. Ask for service
12	Hardware overvoltage	1. big inertia of load, decrease too fast 2. current vibration 3. Grid over-voltage 4. unit fault	1. increase decrease time 2. decrease input voltage 3. Ask for service
13	Reserved	Reserved	Reserved
14	Bypass unit failure	1. Bypass relay fault 2. Bypass relay wiring error	1. Replace bypass relay 2. Check bypass relay wiring

9.3 The action after fault

After CHH series high voltage inverter fault, system latch and indicate fault information, acousto-optic alarm begin.

For system fault, inverter will coast to stop.

For series system fault, such as temperature of phase shift transformer exceed 150°C, system coast to stop with high voltage cut off.

For unit fault, use bypass fault unit according to requirement for derating run without measure to process unit fault. If you check fault unit, stop inverter and cut off high voltage.

Bypass fault unit is only used to deal with one fault unit.

If the fault units more than one, and the unit is not on the bypass location, system trigger fault and cut off high voltage.

CHH high voltage inverter latch fault until user remove the fault, push button to reset the inverter.

The inverter keypad can latch last three fault information, environment information.

The touch screen can latch last several hundred fault information, environment information.

Caution



① Please do not reset and re-run inverter when you do not know the reason of fault, treat the fault after your confirming of the fault level and reason.

② CHH series inverter is complicated electronics converter equipment, inspection or repair must under instruction of manufacture engineer

③ Please make sure the power supply off and filter capacitor discharge completely when you inspection or repair.

9.4 Action after warning

1. system warning introduction

Alarm code	Alarm Name	Reason	Solution
A00.01	Input over voltage	1. Grid voltage too high	Make sure grid voltage within rated voltage vibration range +/-15%
A00.02	Phase shift transformer overheating	1. Overload 2. Environment temperature too high 3. Temperature controller fault 4. Cooling fault. 5. Protection circuit wire under interference. 6. Control cable shield is not right grounding	1. check external signal cable and shield layer ground right or not 2. Check transformer load and environment temperature compare to rated value. 3. check install condition 4. check control cable shield layer grounding right or not 6. Check temperature controller and its circuit.
A00.03	Main control power supply off	1. Off or not plugged 2. Control cabinet main control power supply switcher open(Q1)	1. Inspect main control power supply, make sure connector plug-in 2. Check and make sure Q1 close 3. Check K7 work status, Please replace

		3. Control cabinet main control power supply feed back relay K7 fault	K7 if it can not work properly 4. Ask for service
A00.04	Alternative control power supply off	1. Off or not plugged 2. Control cabinet Alternative control power supply switcher open(Q2) 3. Control cabinet alternative control power supply feed back relay K8 fault	1. Inspect main control power supply,make sure connector plug-in 2. Check and make sure Q2 close 3. Check K8 work status, Please replace K8 if it can not work properly 4. Ask for service
A00.05	FAN fault	1. The power supply for fan from phase shifting transformer off 2.Control cabinet fan's power supply switcher open. 3.Control cabinet fan's power supplyfeed back relay(K10) fault	1. Check phase-shifting auxiliry winding circuit access is ok or not Check and make sure Q3 close 3. Check K10 work status, Please replace K10 if it can not work properly 4. Ask for service
A00.06	UPS fault	1. UPS is not connect properly 2. UPS fault 3. UPS status feed back relay (K9) fault	1.Make sure Ups connected and right operation 2. Check K9 work status, 3. Ask for service

2.Unit warning introduction

Alarm code	Alarm Name	Reason	Solution
AX1X2.01	unit over heating	1.Fan fault 2.Poor cabinet tightness and cooling condition 3. heavy load and current	1. Ask for technical support 2. Select bigger inverter 3. clear dusty on filter net

9.5 Common Faults and Solutions

Inverter may have following faults or malfunctions during operation, please refer to the following solutions.

No light of indicator after power on:

Using keypad/touch screen checking if there is input voltage or not, when there is high voltage, The indicator light.

Check corresponding unit if there is voltage or not through PD.30~PD.56, If not, cut off input and check the wiring between phase shifting transformer and unit.

If unit have voltage, But the indicator is not light, Please check virtual unit of inverter if corresponding to unit with input voltage.

Over voltage during decelerating

- 1) Check input voltage if too high or not
- 2) Increase decreasing time.

10. MAINTENANCE



WARNING

- Maintenance must be performed according to designated maintenance methods.
- Maintenance, inspection and replacement of parts must be performed only by authorized personnel.
- After turning off the main circuit power supply, waiting for 10 minutes before performance maintenance or inspection.
- DO NOT directly touch components or devices of PCB board. Otherwise inverter can be damaged by electrostatic.
- After maintenance, all screws must be tightened.

In order to prevent the fault of inverter to make it operate smoothly in high-performance for a long time, user must inspect the inverter periodically (within half year). The following table indicates the inspection content.

1. Daily Maintenance

<i>Items to be Checked</i>	<i>Inspection content</i>	<i>Means/ criterion</i>
Operation environment	temperature, humidity, dust, vapor, leakage, grease contamination, gases, hazardous material	visual indication See or use instrument check if need the technical regulation
Touch screen	Clear	visual indication display clear
Frame work structure	1)Abnormal vibration or sound 2)screw bolt loose or not 3)damage out of shape 4)dusty or defile or not	visual indication normal
cooling fan	Abnormal vibration or sound or not	Visual, auditory normal
Cooling channel	Block, attached material or not	visual indication normal
phase-shifting transformer	Abnormal temperature or not Abnormal sound or not	Visual, auditory, check interface
High voltage contacor	Abnormal vibration or not, Abnormal sound or not	Visual, auditory normal

2. Periodic Maintenance

General steps of Periodic Maintenance and inspection

- (1)Cut off all of the power supply for high inverter including main power supply and auxiliary power supply
- (2)Confirm Item (1) after waiting for 30 min, confirm power unit discharge.
- (3)Make sure switcher open and grounding correctly
- (4)Open cabinet door of high inverter,check the item one by one according to periodic maintenance.
- (5)Implement maintenance of high voltage
- (6)Confirm the maintenance and inspection work
- (7)Finish the maintenance and inspection
- (8)Comnfirm main, control power supply and control circuit connected properly.
- (9)Make sure without tools or foreign material in cabinet. No other hidden trouble
- (10)Make sure filter do not block
- (11)Electric cabinet door close
- (12)Power on again to make sure maintenance and inspection,
- (13)Fill in maintenance and inspection report
- (14)Hand in receipt maintenance and inspection report.

High voltage inverter periodic maintenance and inspection table

Items inspection	Content	Means/criteria
line conductor	Overheating Discoloration or deformation or not Insulating barrier damaged or discoloration or not	visual inspection to see damage or defile
Terminals	Damage or defile or not Overheating Discoloration or deformation or not Insulating barrier damaged or discoloration or not	Visual inspection; to see damage or defile
Phase shifting transformer	Overheating Discoloration or deformation or not Insulating barrier damaged or discoloration or not Abnormal vibration or smell or not	Visual inspection; to see damage or defile
Power unit	Copper bar loose or not Insulation layer of copper damaged or discoloration	Visual inspection; to see damage or defile
PCB board	Screw and connector loose or not CAbnormal smell or discoloration Crack, damage, out of shape,pocking Capacitor weeping or out of shape or not	Visual inspection Normal
Fuse	Broken or not	Visual inspection,Normal
Cooling fan	Abnormal vibration or sound	Visual,acoustical inspection.
Cabinet structure	Abnormal vibration or sound or not Screw bolt loose or not Out of shape to be damage or not Dusty, defile or not	Visual, acoustical
Insulation	Need electric technical criteria or not	Refer to insulating test

performance	
Filter capacity	Weeping, discoloration, crack, shell expand Measure static capacitor Visual and instrument inspection

3.Device replacement

In order to make sure inverter work for long time, periodic maintenance is a must according to useful time of inverter internal electronics components, the useful time is different because of environment and working condition different, please refer to table as below

Inverter component replace time

<i>Device Name</i>	<i>Years</i>
Cooling fan	2~3 year
Capacitor	4~5 year
PCB board	5~8 year
Fuse	10 year

Working condition for replace time of Inverter components

Environment temperature: average temperature 30 °C

Load coefficient: 80% below

Appendix 1

General knowledge of EMC

EMC is the abbreviation of electromagnetic compatibility, which means the device or system has the ability to work normally in the electromagnetic environment and will not generate any electromagnetic interference to other equipments.

EMC includes two subjects: electromagnetic interference and electromagnetic anti-jamming.

According to the transmission mode, Electromagnetic interference can be divided into two categories: conducted interference and radiated interference.

Conducted interference is the interference transmitted by conductor. Therefore, any conductors (such as wire, transmission line, inductor, capacitor and so on) are the transmission channels of the interference.

Radiated interference is the interference transmitted in electromagnetic wave, and the energy is inverse proportional to the square of distance.

Three necessary conditions or essentials of electromagnetic interference are: interference source, transmission channel and sensitive receiver. For customers, the solution of EMC problem is mainly in transmission channel because of the device attribute of disturbance source and receiver can not be changed.

Like other electric or electronic devices, inverter is not only an electromagnetic interference source but also an electromagnetic receiver. The operating principle of inverter determines that it can produce certain electromagnetic interference noise. And the same time inverter should be designed with certain anti-jamming ability to ensure the smooth working in certain electromagnetic environment. The following is its EMC features:

- ① Input current is non-sine wave. The input current includes large amount of high-harmonic waves that can cause electromagnetic interference, decrease the grid power factor and increase the line loss.
- ② Output voltage is high frequency PMW wave, which can increase the temperature rise and shorten the life of motor. And the leakage current will also increase, which can lead to the leakage protection device malfunction and generate strong electromagnetic interference to influence the reliability of other electric devices.
- ③ As the electromagnetic receiver, too strong interference will damage the inverter and influence the normal using of customers.
- ④ In the system, EMS and EMI of inverter coexist. Decrease the EMI of inverter can increase its EMS ability.

In order to ensure all electric devices in the same system to work smoothly, this section, based on EMC features of inverter, introduces EMC installation process in several aspects of application (noise control, site wiring, grounding, leakage current and power supply filter). The good effective of EMC will depend on the good effective of all of these five aspects.

1 Noise control

All the connections to the control terminals must use shielded wire. And the shield layer of the wire must ground near the wire entrance of inverter. The ground mode is 360 degree annular connection formed by cable clips. It is strictly prohibitive to connect the twisted shielding layer to the ground of inverter, which greatly decreases or loses the shielding effect.

Connect inverter and motor with the shielded wire or the separated cable tray. One side of shield layer of shielded wire or metal cover of separated cable tray should connect to ground, and the other side should connect to the motor cover. Installing an EMC filter can reduce the electromagnetic noise greatly.

2 Site wiring

Power supply wiring: the power should be separated supplied from electrical transformer. Normally it is 5 core wires, three of which are fire wires, one of which is the neutral wire, and one of which is the ground wire. It is strictly prohibitive to use the same line to be both the neutral wire and the ground wire

Device categorization: there are different electric devices contained in one control cabinet, such as inverter, filter, PLC and instrument etc, which have different ability of emitting and withstanding electromagnetic noise. Therefore, it needs to categorize these devices into strong noise device and noise sensitive device. The same kinds of device should be placed in the same area, and the distance between devices of different category should be more than 20cm.

Wire Arrangement inside the control cabinet: there are signal wire (light current) and power cable (strong current) in one cabinet. For the inverter, the power cables are categorized into input cable and output cable. Signal wires can be easily disturbed by power cables to make the equipment malfunction.

Therefore when wiring, signal cables and power cables should be arranged in different area. It is strictly prohibitive to arrange them in parallel or interlacement at a close distance (less than 20cm) or tie them together. If the signal wires have to cross the power cables, they should be arranged in 90 angles. Power input and output cables should not either be arranged in interlacement or tied together, especially when installed the EMC filter. Otherwise the distributed capacitances of its input and output power cable can be coupling each other to make the EMC filter out of function.

3 Ground

Inverter must be ground safely when in operation. Grounding enjoys priority in all EMC methods because it does not only ensure the safety of equipment and persons, but also is the simplest, most effective and lowest cost solution for EMC problems.

Grounding has three categories: special pole grounding, common pole grounding and series-wound grounding. Different control system should use special pole grounding, and different devices in the same control system should use common pole grounding, and different devices connected by same power cable should use series-wound grounding.

4 Leakage Current

Leakage current includes line-to-line leakage current and over-ground leakage current. Its value depends on distributed capacitances and carrier frequency of inverter. The over-ground leakage current, which is the current passing through the common ground wire, can not only flow into inverter system but also other devices. It also can make leakage current circuit breaker, relay or other devices malfunction. The value of line-to-line leakage current, which means the leakage current passing through distributed capacitors of input output wire, depends on the carrier frequency of inverter, the length and section areas of motor cables. The higher carrier frequency of inverter, the longer of the motor cable and/or the bigger cable section area, the larger leakage current will occur.

Countermeasure:

Decreasing the carrier frequency can effectively decrease the leakage current. In the case of motor cable is relatively long (longer than 50m), it is necessary to install AC reactor or sinusoidal wave filter at the output side, and when it is even longer, it is necessary to install one reactor at every certain distance.

Appendix 2

Interfaces

RS485: asynchronous, half-duplex.

Default: 8-E-1, 19200bps. See Group PC parameter settings.

Communication Modes

1. The protocol is Modbus protocol. Besides the common register Read/Write operation, it is supplemented with commands of parameters management.

2 The drive is a slave in the network. It communicates in 'point to point' master-slave mode. It will not respond to the command sent by the master via broadcast address.

3 In the case of multi-drive communication or long-distance transmission, connecting a 100~120Ω resistor in parallel with the master signal line will help to enhance the immunity to interference.

Protocol Format

Modbus protocol supports both RTU and ASCII mode. The frame format is illustrated as follows:

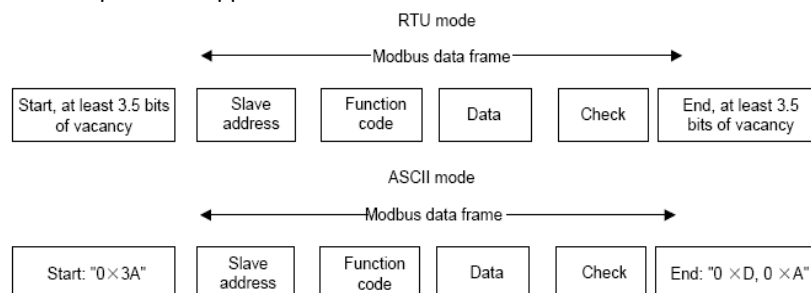

Modbus adopts "Big Endian" representation for data frame. This means that when a numerical quantity larger than a byte is transmitted, the most significant byte is sent first.

RTU mode

In RTU mode, the Modbus minimum idle time between frames should be no less than 3.5 bytes. The checksum adopts CRC-16 method. All data except checksum itself sent will be counted into the calculation. Please refer to section: CRC Check for more information. Note that at least 3.5 bytes of Modbus idle time should be kept and the start and end idle time need not be summed up to it.

The table below shows the data frame of reading parameter 002 from slave node address 1.

Node addr.	Command	Data addr.	Read No.	CRC
0x01	0x03	0x00 0x02	0x00 0x01	0x25 0xCA

The table below shows the reply frame from slave node address 1

Node addr.	Command	Bytes No.	Data	CRC
0x01	0x03	0x02	0x00 0x00	0xB8 0x44

ASCII mode

In ASCII mode, the frame head is "0x3A", and default frame tail is "0x0D" or "0x0A". The frame tail can also be configured by users. Except frame head and tail, other bytes will be sent as two ASCII characters, first sending higher nibble and then lower nibble. The data have 7/8 bits. "A"~"F" corresponds to the ASCII code of respective capital letter. LRC check is used. LRC is calculated by adding all the successive bytes of the message except the head and tail, discarding any carriers, and then two's complementing the result.

Example of Modbus data frame in ASCII mode:

The command frame of writing 0x0003 into address "0x1000" of slave node address 1 is shown in the

table below:

LRC checksum = the complement of (01+06+10+00+0x00+0x03) = 0xE5

	Frame head	Node addr.		Command		Data addr.			
Code		0	1	0	6	1	0	0	0
ASCII	3A	30	31	30	36	31	30	30	30
Data to write				LRC		Frame tail			
0	0	0	3	E	5	CR		LF	
30	30	30	33	45	35	0D		0A	

Protocol function

Different respond delay can be set through drive's parameters to adapt to different needs. For RTU mode, the respond delay should be no less than 3.5 bytes interval, and for ASCII mode, no less than 1ms.

The main function of Modbus is to read and write parameters. The Modbus protocol supports the following commands:

0x03	Read inverter's function parameter and status parameters
0x06	Write single function parameter or command parameter to inverter

All drive's function parameters, control and status parameters are mapped to Modbus R/W data address. The data addresses of each function parameters please refer the sixth column of chapter 9.

The data address of control and status parameters please refer to the following table.

Parameter Description	Address	Meaning of value	R/W Feature
Control command	1000H	0001H: Forward	W/R
		0002H: Reverse	
		0003H: JOG forward	
		0004H: JOG reverse	
		0005H: Stop	
		0006H: Coast to stop	
		0007H: Reset fault	
		0008H: JOG stop	
Inverter status	1001H	0001H: Forward running	R
		0002H: Reverse running	
		0003H: Standby	
		0004H: Fault	
		0005H: POFF status	
Communication setting	2000H	Communication Setting Range (-Fmax~Fmax)	W/R
	2001H	If it is set as PID (preset value or feedback value), the value is the percentage of the PID.	
	2002H	0001H:variable frequency	
		0002H:power frequency	
		0003H:switch to power frequency from variable frequency	
		0004H: switch to variable frequency from power frequency	
		0005H:Cut off high voltage	
2003H	Virtual terminal address setting with range (0~0xFFFF)		
Status parameters	3000H	Output frequency	R
	3001H	Reference frequency	R
	3002H	DC Bus voltage	R
	3003H	Output voltage	R
	3004H	Output current	R

	3005H	Rotation speed	R
	3006H	Output power	R
	3007H	Output torque	R
	3008H	PID preset value	R
	3009H	PID feedback value	R
	300AH	Input terminal status	R
	300BH	Output terminal status.	R
	300CH	Input of AI1	R
	300DH	Input of AI2	R
	300EH	Input of AI3	R
	300FH	HDI frequency	R
	3010H	Reserved	R
	3011H	Reserved	R
	3012H	Step No. of multi-step	R
	3013H	Reserved	R
	3014H	Reserved	R
	3015H	Reserved	R
	3016H	Device code	R
	3017H	Power status:Bit0:KM1 status Bit1:KM2 status, Bit2:KM3 status, Bit3:QF status Bit4:variable frequency status Bit5:power frequency status Bit6: Running status ready status. Bit7:bypass unit status	R
	3018H	Input terminal status	R
	3019H	Output terminal status	R
	301AH	Effective unit selectable bit	R
	301BH	Running control channel: 0:Keypad 1:Terminal 2:Communication	R
Fault info address	5000H	This address stores the fault type of inverter. The meaning of each value is same as P7.15.	R

The above shows the format of the frame. Now we will introduce the Modbus command and data structure in details, which is called protocol data unit for simplicity. Also MSB stands for the most significant byte and LSB stands for the least significant byte for the same reason. The description below is data format in RTU mode. The length of data unit in ASCII mode should be doubled.

Protocol data unit format of reading parameters:

Request format:

Protocol data unit	Data length(bytes)	Range
Command	1	0x03
Data Address	2	0~0xFFFF
Read number	2	0x0001~0x0010

Reply format (success):

Protocol data unit	Data length(bytes)	Range
Command	1	0x03
Returned byte number	2	2* Read number
Content	2* Read number	

If the operation fails, the inverter will reply a message formed by failure command and error code. The failure command is (Command+0x80). The error code indicates the reason of the error; see the table

below.

Value	Name	Mean
01H	Illegal command	The command from master can not be executed. The reason maybe: 1. This command is only for new version and this version can not realize. 2. Slave is in fault status and can not execute it.
02H	Illegal data address.	Some of the operation addresses are invalid or not allowed to access.
03H	Illegal value	When there are invalid data in the message framed received by slave. Note: This error code does not indicate the data value to write exceed the range, but indicate the message frame is a illegal frame.
06H	Slave busy	Inverter is busy(EEPROM is storing)
10H	Password error	The password written to the password check address is not same as the password set by P7.00.
11H	Check error	The CRC (RTU mode) or LRC (ASCII mode) check not passed.
12H	Written not allowed.	It only happen in write command, the reason maybe: 1. the data to write exceed the range of according parameter 2. The parameter should not be modified now. 3. The terminal has already been used.
13H	System locked	When password protection take effect and user does not unlock it, write/read the function parameter will return this error.

Protocol data unit format of writing single parameter:

Request format:

Protocol data unit	Data length(bytes)	Range
Command	1	0x06
Data Address	2	0~0xFFFF
Write Content	2	0~0xFFFF

Reply format (success):

Protocol data unit	Data length(bytes)	Range
Command	1	0x06
Data Address	2	0~0xFFFF
Write Content	2	0~0xFFFF

Note:

10.5.1 Between frames, the span should not less than 3.5 bytes interval, otherwise, the message will be discarded.

10.5.2 Be cautious to modify the parameters of PC group through communication, otherwise may cause the communication interrupted.

10.5.3 In the same frame, if the span between two .near bytes more than 1.5 bytes interval, the behind bytes will be assumed as the start of next message so that communication will failure.

CRC Check

For higher speed, CRC-16 uses tables. The following are C language source code for CRC-16.

```

unsigned int crc_cal_value(unsigned char *data_value,unsigned char data_length)
{
int i;
unsigned int crc_value=0xffff;
while(data_length--)
{
crc_value^=*data_value++;
for(i=0;i<8;i++)
{

```

```

if(crc_value&0x0001)crc_value=(crc_value>>1)^0xa001;
else crc_value=crc_value>>1;
}
}
return(crc_value);
}

```

Example

1. RTU mode, read 2 data from 0004H

The request command is:

START	T1-T2-T3-T4 (transmission time of 3.5 bytes)
Node address	01H
Command	03H
High byte of start address	00H
Low byte of start address	04H
High byte of data number	00H
Low byte of data number	02H
Low byte of CRC	85H
High byte of CRC	CAH
END	T1-T2-T3-T4 (transmission time of 3.5 bytes)

The reply is :

START	T1-T2-T3-T4 (transmission time of 3.5 bytes)
Node address	01H
Command	03H
Returned byte number	04H
Higher byte of 0004H	00H
Low byte of 0004H	00H
High byte of 0005H	00H
Low byte of 0005H	00H
Low byte of CRC	43H
High byte of CRC	07H
END	T1-T2-T3-T4 (transmission time of 3.5 bytes)

2. ASCII mode, read 2 data from 0004H:

The request command is:

START	‘:’
Node address	‘0’
	‘1’
Command	‘0’
	‘3’
High byte of start address	‘0’

	'0'
Low byte of start address	'0'
	'4'
High byte of data number	'0'
	'0'
Low byte of data number	'0'
	'2'
LRC CHK Hi	'F'
LRC CHK Lo	'6'
END Lo	CR
END Hi	LF

The reply is

START	':'
Node address	'0'
	'1'
Command	'0'
	'3'
Returned byte number	'0'
	'4'
Higher byte of 0004H	'0'
	'0'
Low byte of 0004H	'0'
	'0'
High byte of 0005H	'0'
	'0'
Low byte of 0005H	'0'
	'0'
LRC CHK Lo	'F'
LRC CHK Hi	'8'
END Lo	CR
END Hi	LF

3. RTU mode, write 5000(1388H) into address 0008H, slave node address 02.

The request command is:

START	T1-T2-T3-T4 (transmission time of 3.5 bytes)
Node address	02H
Command	06H
High byte of data address	00H
Low byte of data address	08H
High byte of write content	13H
Low byte of write content	88H
Low byte of CRC	05H
High byte of CRC	6DH
END	T1-T2-T3-T4 (transmission time of 3.5 bytes)

The reply command is:

START	T1-T2-T3-T4 (transmission time of 3.5
-------	---------------------------------------

	bytes)
Node address	02H
Command	06H
High byte of data address	00H
Low byte of data address	08H
High byte of write content	13H
Low byte of write content	88H
Low byte of CRC	05H
High byte of CRC	6DH
END	T1-T2-T3-T4 (transmission time of 3.5 bytes)

4.ASCII mode, write 5000(1388H) into address 0008H, slave node address 02.

The request command is:

START	‘:’
Node address	‘0’
	‘2’
Command	‘0’
	‘6’
High byte of data address	‘0’
	‘0’
Low byte of data address	‘0’
	‘8’
High byte of write content	‘1’
	‘3’
Low byte of write content	‘8’
	‘8’
LRC CHK Hi	‘5’
LRC CHK Lo	‘5’
END Lo	CR
END Hi	LF

The reply command is:

START	‘:’
Node address	‘0’
	‘2’
Command	‘0’
	‘6’
High byte of data address	‘0’
	‘0’
Low byte of data address	‘0’
	‘8’
High byte of write content	‘1’
	‘3’
Low byte of write content	‘8’
	‘8’
LRC CHK Hi	‘5’
LRC CHK Lo	‘5’

END Lo	CR
END Hi	LF

Appendix 3

High inverter LIST OF FUNCTION PARAMETERS

Function Code	Name	Description	Factory Setting	Modify	Serial No	No.
P0 Group: Basic Function						
P0.00	Speed control mode	0: V/F control 1: Vector control(reserved)	0~1	0	●	0.
P0.01	Run command source	0: Keypad (LED extinguished) 1: Terminal (LED flickering) 2: Communication (LED lights on)	0~2	0	○	1.
P0.02	UP/DOWN setting	0: Valid, save UP/DOWN value when power off 1: Valid, do not save UP/DOWN value when power off 2: Invalid 3:Valid during running, clear when power off	0~3	0	○	2.
P0.03	Frequency A command source	0: Keypad 1: AI1 2: AI3 3: HDI1 4:Simple PLC 5: Multi-Step speed 6: PID 7: Communication	0~7	0	○	3.
P0.04	Frequency B command source	0: AI1 1: AI2 2: AI3 3: HDI	0~3	0	○	4.
P0.05	Scale of frequency B command	0: Maximum frequency 1: Frequency A command	0~1	0	○	5.
P0.06	Frequency command selection	0:A 1:B 2:A+B 3:Max(A,B)	0~3	0	○	6.
P0.07	Maximum frequency	P0.08~120.00Hz	P0.08~120.00	50.00Hz	◎	7.
P0.08	Upper frequency limit	P0.09~ P0.07	P0.09~P0.07	50.00Hz	○	8.
P0.09	Lower frequency limit	0.00 ~ P0.08	0.00~P0.05	0.00Hz	○	9.
P0.10	Keypad reference frequency	0.00 ~ P0.07	0.00~P0.05	50.00Hz	○	10.

Function Code	Name	Description	Factory Setting	Modify	Serial No	No.
P0.11	Acceleration time 0	0.1~3600.0s	0.1~3600.0	Depends on model	○	11.
P0.12	Deceleration time 0	0.1~3600.0s	0.1~3600.0	Depends on model	○	12.
P0.13	Running direction selection	0: Forward 1: Reverse 2: Forbid reverse	0~2	0	◎	13.
P0.14	Carrier frequency setting	0.5~2.0kHz	0.5~2.0	Depends on model	◎	14.
P0.15	Motor parameters autotuning	0: No action 1: autotuning(reserved)	0~1	0	◎	15.
P0.16	Restore parameters	0: No action 1: Restore factory setting 2: Clear fault records 3: Restore parameters for injection molding machine	0~2	0	◎	16.
P0.17	AVR function	0: Disabled 1: Enabled all the time 2: Disabled during deceleration	0~2	1	○	17.
P1 Group: Start and Stop Control						
P1.00	Start Mode	0: Start directly 1: DC braking and start 2: Speed tracking and start	0~2	0	◎	18.
P1.01	Starting frequency	0.00~10.00Hz	0.00~10.00	0.50Hz	◎	19.
P1.02	Hold time of starting frequency	0.0~50.0s	0.0~50.0	0.0s	◎	20.
P1.03	DC Braking current before start	0.0~120.0%	0.0~120.0	0.0%	◎	21.
P1.04	DC Braking time before start	0.0~50.0s	0.0~50.0	0.0s	◎	22.
P1.05	Stop Mode	0: Deceleration to stop 1: Coast to stop	0~1	0	○	23.
P1.06	Starting frequency of DC braking	0.00~10.00Hz	0.00~10.00	0.00Hz	○	24.
P1.07	Waiting time before DC braking	0.0~50.0s	0.0~50.0	0.0s	○	25.
P1.08	DC braking current	0.0~120.0%	0.0~120.0	0.0%	○	26.
P1.09	DC braking time	0.0~50.0s	0.0~50.0	0.0s	○	27.
P1.10	Dead time of FWD/REV	0.0~3600.0s	0.0~3600.0	0.0s	○	28.
P1.11	Action when running frequency is less than lower frequency limit	0: Running at the lower frequency limit 1: Stop 2: Stand-by	0~2	0	◎	29.

Function Code	Name	Description	Factory Setting	Modify	Serial No	No.
P1.12	Restart after power off	0: Disabled 1: Enabled	0~1	0	○	30.
P1.13	Delay time for restart	0.0~3600.0s	0.0~3600.0	0.0s	○	31.
P1.14	High voltage switcher action selection when stop	0:cut off high voltage supply 1:Holding	0~1	1	○	32.
P1.15	Waiting time of switching on	0.0~3600.0s	0.0~3600.0s	10.0 s	○	33.
P1.16	Waiting time of running in order	0.0~3600.0s	0.0~3600.0s	10.0 s	○	34.
P2 Group: Motor Parameters						
P2.00	Inverter Model	0:asynchronous motor 1:synchronous motor(reserved)	0~1	0	●	35.
P2.01	Motor rated power	4.0~5000.0kW	4.0~5000.0	Depends on model	◎	36.
P2.02	Motor rated frequency	10.00~P0.07	10.00~P0.07	50.00Hz	◎	37.
P2.03	Motor rated speed	1~36000rpm	1~36000	985rpm	◎	38.
P2.04	Motor rated voltage	0~20000V	0~20000	Depends on model	◎	39.
P2.05	Motor rated current	0.8~3000.0A	0.8~3000.0	Depends on model	◎	40.
P2.06	Motor stator resistance	0.001~65.535Ω	0.001~65.535	Depends on model	○	41.
P2.07	Motor rotor resistance	0.001~65.535Ω	0.001~65.535	Depends on model	○	42.
P2.08	Motor leakage inductance	0.1~6553.5mH	0.1~6553.5	Depends on model	○	43.
P2.09	Motor mutual inductance	0.1~6553.5mH	0.1~6553.5	Depends on model	○	44.
P2.10	Current without load	0.01~655.35A	0.01~655.35	Depends on model	○	45.
P3 Auxiliary function group						

Function Code	Name	Description	Factory Setting	Modify	Serial No	No.
P3.00	Acceleration time 1	0.1~3600.0s	0.1~3600.0	Depends on model	○	46.
P3.01	Deceleration time 1	0.1~3600.0s	0.1~3600.0	Depends on model	○	47.
P3.02	Acceleration time 2	0.1~3600.0s	0.1~3600.0	Depends on model	○	48.
P3.03	Deceleration time 2	0.1~3600.0s	0.1~3600.0	Depends on model	○	49.
P3.04	Acceleration time 3	0.1~3600.0s	0.1~3600.0	Depends on model	○	50.
P3.05	Deceleration time 3	0.1~3600.0s	0.1~3600.0	Depends on model	○	51.
P3.06	Jog reference	0.00~P0.07	0.00~P0.07	5.00Hz	○	52.
P3.07	Jog acceleration time	0.1~3600.0s	0.1~3600.0	Depends on model	○	53.
P3.08	Jog deceleration time	0.1~3600.0s	0.1~3600.0	Depends on model	○	54.
P3.09	Skip frequency 1	0.00~P0.07	0.00~P0.07	0.00Hz	○	55.
P3.10	Skip frequency bandwidth 1	0.00~P0.07	0.00~P0.07	0.00Hz	○	56.
P3.11	Skip frequency 2	0.00~P0.07	0.00~P0.07	0.00Hz	○	57.
P3.12	Skip frequency bandwidth 2	0.00~P0.07	0.00~P0.07	0.00Hz	○	58.
P3.13	Auto reset times	0~3	0~3	0	○	59.
P3.14	Reset interval	0.1~100.0s	0.1~100.0	1.0s	○	60.
P3.15	FDT level	0.00~P0.07	0.00~P0.07	50.00Hz	○	61.
P3.16	FDT lag	0.0~100.0%	0.0~100.0	5.0%	○	62.
P3.17	Frequency arrive detecting range	0.0~100.0%	0.0~100.0	0.0%	○	63.

Function Code	Name	Description	Factory Setting	Modify	Serial No	No.
P3.18	Over modulation selection	0:invalid 1:valid	0~1	0	○	64.
P3.19	Operation mode of cooling fans	0:Automatics stopping 1:Operating all the time	0~1	0	○	65.
P3.20	Alarm reset intervals	0.0:Alarm invalid 0.1~3600.0s	0.0~3600.0	0.0	○	66.
P4 Group: V/F Control						
P4.00	V/F curve selection	0:Linear curve 1: User-defined curve 2:Torque_stepdown curve (1.3 order) 3:Torque_stepdown curve (1.7 order) 4: Torque_stepdown curve (2.0 order)	0~4	0	◎	67.
P4.01	Torque boost	0.0%:(AUTO)0.1%~10.0%	0.0~10.0	0.1%	○	68.
P4.02	Torque boost cut-off	0.0%~50.0%	0.0~50.0	20.0%	◎	69.
P4.03	V/F slip compensation	0.0~200.0%	0.0~200.0	0.0%	○	70.
P4.04	Auto energy saving selection	0:invalid 1:valid	0~1	0	◎	71.
P4.05	V/F frequency 1	0.00Hz~P4.07	0.00~P4.07	0.00Hz	○	72.
P4.06	V/F voltage 1	0.0%~100.0%	0.0~100.0	0.0%	○	73.
P4.07	V/F frequency 2	P4.05~P4.09	P4.05~P4.09	0.00Hz	○	74.
P4.08	V/F voltage2	0.0%~100.0%	0.0~100.0	0.0%	○	75.
P4.09	V/F frequency 3	P4.07~P2.02	P4.07~P2.01	0.00Hz	○	76.
P4.10	V/F voltage 3	0.0%~100.0%	0.0~100.0	0.0%	○	77.
P4.11	Modulate waveform	0:SPWM 1 1:SPWM 2	0~1	0	◎	78.
P5 Group: Input Terminals						
P5.00	S1 Terminal function	0:Invalid 1:Forward	0~39	0	◎	79.
P5.01	S2 Terminal function	2:Reverse 3:3-wire control	0~39	0	◎	80.
P5.02	S3 Terminal function	4:Jog forward 5:Jog reverse	0~39	0	◎	81.
P5.03	S4 Terminal function	6:Coast to stop 7:Reset fault	0~39	0	◎	82.
P5.04	S5 Terminal function		0~39	0	◎	83.

Function Code	Name	Description	Factory Setting	Modify	Serial No	No.
P5.05	S6 Terminal function	8:External fault normal close input	0~39	0	◎	84.
P5.06	S7 Terminal function	9:External fault normal Open input	0~39	0	◎	85.
P5.07	S8 Terminal function	10:Up command	0~39	0	◎	86.
P5.08	S9 Terminal function	11:DOWN command	0~39	0	◎	87.
P5.09	S10 Terminal function	12:Clear UP/DOWN 13:Clear UP/DOWN (Temporary)	0~39	0	◎	88.
P5.10	S11 Terminal function	14:ACC/DEC time selection1	0~39	0	◎	89.
P5.11	S12 Terminal function	15:ACC/DEC time selection 2	0~39	0	◎	90.
P5.12	S13 Terminal function	16:Multi-step speed reference1	0~39	0	◎	91.
P5.13	S14 Terminal function	17:Multi-step speed reference 2	0~39	0	◎	92.
P5.14	S15 Terminal function	18:Multi-step speed reference 3	0~39	0	◎	93.
P5.15	S16 Terminal function	19:Multi-step speed reference 4 20:Multi-step speed pause 21:Switch between A and B 22:Switch between A and A+B 23:Switch between B and A+B 24:Pause PID 25:Pause operation 26:ACC/DEC ramp hold 27~29:Reserved 30:Available frequency running 31:Power frequency running 32:Switching from variable frequency to power frequency 33: Switching from power frequency to variable frequency. 34: Emergency breaking input of high voltage 35: Running command switch to keypad 36: Running command switch to terminals 37: Running command switch to communication 38: Input signals of high voltage switch on. 39:Reserved	0~39	0	◎	94.
P5.16	Polar selection of	0x0000~0xFFFF	0000~FFFF	0000	○	95.

Function Code	Name	Description	Factory Setting	Modify	Serial No	No.
	input terminal					
P5.17	Filter time of ON/OFF	1~10	1~10	5	○	96.
P5.18	FWD/REV terminals control mode	0: 2-wire control mode 1 1: 2-wire control mode 2 2: 3-wire control mode 1 3: 3-wire control mode 2	0~3	0	◎	97.
P5.19	UP setting change rate	0.01~50.00Hz/s	0.01~50.00	0.50Hz/s	○	98.
P5.20	DOWN setting change rate	0.01~50.00Hz/s	0.01~50.00	0.50Hz/s	○	99.
P5.21	AI1 lower limit	0.00V~P5.23	0.00~P5.23	0.00V	○	100.
P5.22	AI1 lower limit corresponding setting	-100.0%~100.0%	-100.0~100.0	0.0%	○	101.
P5.23	AI1 upper limit	P5.21~10.00V	P5.21~10.00	10.00V	○	102.
P5.24	AI1 upper limit corresponding setting	-100.0%~100.0%	-100.0~100.0	100.0%	○	103.
P5.25	AI1 filter time constant	0.00s~10.00s	0.00~10.00	0.10s	○	104.
P5.26	AI2 lower limit	0.00V~P5.28	0.00~P5.28	0.00V	○	105.
P5.27	AI2 lower limit corresponding setting	-100.0%~100.0%	-100.0~100.0	0.0%	○	106.
P5.28	AI2 upper limit	P5.26~10.00V	P5.26~10.00	10.00V	○	107.
P5.29	AI2 upper limit corresponding setting	-100.0%~100.0%	-100.0~100.0	100.0%	○	108.
P5.30	AI2 filter time constant	0.00s~10.00s	0.00~10.00	0.10s	○	109.
P5.31	AI3 lower limit	-10.00V~P5.33	-10.00~P5.33	-10.00V	○	110.
P5.32	AI3 lower limit corresponding setting	-100.0%~100.0%	-100.0~100.0	-100.0%	○	111.
P5.33	AI3 upper limit	P5.31~10.00V	P5.31~10.00	10.00V	○	112.
P5.34	AI3 upper limit corresponding setting	-100.0%~100.0%	-100.0~100.0	100.0%	○	113.
P5.35	AI3 filter time constant	0.00s~10.00s	0.00~10.00	0.10s	○	114.
P5.36	HDI1 lower limit	0.000 KHz~P5.38	0.000~P5.38	0.000KHz	○	115.
P5.37	HDI1 lower limit corresponding setting	-100.0%~100.0%	-100.0~100.0	0.0%	○	116.
P5.38	HDI1 upper limit	P5.36~50.000KHz	P5.36~50.000	50.000KHz	○	117.
P5.39	HDI1 upper limit corresponding setting	-100.0%~100.0%	-100.0~100.0	100.0%	○	118.

Function Code	Name	Description	Factory Setting	Modify	Serial No	No.
P5.40	HDI1 filter time constant	0.00s~10.00s	0.00~10.00	0.10s	○	119.
P6 Group: Output Terminals						
P6.00	Relay 1 output selection	0:No output 1:Run FOR/REV	0~20	0	○	120.
P6.01	Relay 2 output selection	2:Fault output 3:FDT reached 4:Frequency reached	0~20	0	○	121.
P6.02	Relay 3 output selection	5:Zero speed running 6:Variable frequency 7:Power frequency	0~20	0	○	122.
P6.03	Relay 4 output selection	9:Upper frequency limit reached	0~20	0	○	123.
P6.04	Relay 5 output selection	10:Lower frequency limit reached	0~20	0	○	124.
P6.05	Relay 6 output selection	11:Ready for high voltage power on 12:Alarm output	0~20	0	○	125.
P6.06	Relay 7 output selection	13:Status of KM1 14:Status of KM2 15:Status of KM3	0~20	0	○	126.
P6.07	Relay 8 output selection	16:Permission of high voltage switcher on 17:Emergency breaking of high voltage 18~20: No output	0~20	0	○	127.
P6.08	HDO ON-OFF output selection	0:Running frequency 1:Reference frequency 2:Inverter output current 3:Motor current 4:Output voltage 5:Output power 6:Output torque 7:A11 voltage 8:A12 voltage 9:A13 voltage	0~24	0	○	128.
P6.09	AO1 output selection	10:Input line voltage of RS 11:Input line voltage of ST 12:Input line voltage of TR 13:Output line voltage of AB 14:Output line voltage of BC 15:Output line voltage of CA 16:Input current of R phase 17:Input current of S phase 18:Input current of T phase 19:Output current of A phase 20:Output current of B phase 21:Output current of C phase	0~24	0	○	129.
P6.10	AO2 output selectio	22:A phase modulate waveform	0~24	0	○	130.
P6.11	AO3 output selection	23:B phase modulate	0~24	0	○	131.

Function Code	Name	Description	Factory Setting	Modify	Serial No	No.
P6.12	AO4 output selection	waveform 24:C phase modulate waveform	0~24	0	○	132.
P6.13	HDO lower limit	0.00%~P6.15	0.00~P6.15	0.00%	○	133.
P6.14	HDO lower limit corresponding output	0.000~50.000kHz	0.000~50.000	0.000kHz	○	134.
P6.15	HDO upper limit	P6.13~100.0%	P6.13~100.00	100.0%	○	135.
P6.16	HDO upper limit corresponding output	0.0~50.000kHz	0.000~50.000	50.000kHz	○	136.
P6.17	AO1 lower limit	0.0%~P6.19	0.0~P6.19	0.0%	○	137.
P6.18	AO1 lower limit corresponding output	0.00V~10.00V	0.00~10.00	0.00V	○	138.
P6.19	AO1 upper limit	P6.17~100.0%	P6.17~100.0	100.0%	○	139.
P6.20	AO1 upper limit corresponding output	0.00V~10.00V	0.00~10.00	10.00V	○	140.
P6.21	AO2 lower limit	0.0%~P6.23	0.0~P6.23	0.0%	○	141.
P6.22	AO2 lower limit corresponding output	0.00V ~10.00V	0.00~10.00	0.00V	○	142.
P6.23	AO2 upper limit	P6.21~100.0%	P6.21~100.0	100.0%	○	143.
P6.24	AO2 upper limit corresponding output	0.00V~10.00V	0.00~10.00	10.00V	○	144.
P6.25	AO3 lower limit	0.0%~P6.27	0.0~P6.27	0.0%	○	145.
P6.26	AO3 lower limit corresponding output	0.00V~10.00V	0.00~10.00	0.00V	○	146.
P6.27	AO3 upper limit	P6.25~100.0%	P6.25~100.0	100.0%	○	147.
P6.28	AO3 upper limit corresponding output	0.00V~10.00V	0.00~10.00	10.00V	○	148.
P6.29	AO4 lower limit	0.0%~P6.31	0.0~P6.31	0.0%	○	149.
P6.30	AO4 lower limit corresponding output	0.00V ~10.00V	0.00~10.00	0.00V	○	150.
P6.31	AO4 upper limit	P6.29~100.0%	P6.29~100.0	100.0%	○	151.
P6.32	AO4 upper limit corresponding output	0.00V~10.00V	0.00~10.00	10.00V	○	152.
P7 Group: Display Interface						
P7.00	User password	0~65535	0~65535	0	○	153.

Function Code	Name	Description	Factory Setting	Modify	Serial No	No.
P7.01	LCD language selection	0:Chinese 1:ENGLISH(Reserved)	0~1	0	○	154.
P7.02	Parameter copy	0: Invalid 1: Upload parameters to LCD 2: Download parameters from LCD	0~2	0	◎	155.
P7.03	QUICK/JOG function selection	0: Quick debugging mode 1: FDW/REV switching 2: Jog	0~2	0	○	156.
P7.04	STOP/RST function selection	0: Valid when keypad control (P0.01=0) 1: Valid when keypad or terminal control (P0.01=0 or 1) 2: Valid when keypad or communication control (P0.01=0 or 2) 3: Always valid	0~3	0	○	157.
P7.05	Time setting	00.00~23.59	00.00~23.59	Real time	○	158.
P7.06	Running status display selection1	0x0000~0xFFFF BIT0:Running frequency(Hz) BIT1:Setting frequency (Hz) BIT2:Input voltage(V) BIT3:Output voltage(V) BIT4:Output current(A) BIT5:Running speed(rpm) BIT6:线速度 BIT7:Output power rating(%) BIT8:Output torque (%) BIT9:PID giving value(%) BIT10:PID Feedback value(%) BIT11:Input terminal status BIT12:Output terminal status BIT13:Analog AI1 Value(V) BIT14: Analog AI2 Value(V) BIT15: Analog AI3 Value(V)	0~FFFF	0FFF	○	159.
P7.07	Running status display selection2	0x0000~0xFFFF BIT0:HDI frequency value BIT1:Current step of	0000~FFFF	0000	○	160.

Function Code	Name	Description	Factory Setting	Modify	Serial No	No.
		multi-steps BIT2:Input power factor(%) BIT3:Input current(A) BIT4:Percentage of current relate to motor rated current(%) BIT5: Percentage of current relate to inverter rated current(%) BIT6:Running time BIT7:Time BIT8:Inverter input terminals status BIT9:Inverter Output terminal status BIT10~BIT15				
P7.08	Stop status display selection	0x0000~0xFFFF BIT0:Frequency setting BIT1: Input voltage BIT2:User input terminal status BIT3:User output terminal status BIT4:PID giving value BIT5:PID feedback value BIT6:Analog AI1 value BIT7:Analog AI2 value BIT8: Analog AI3 value BIT9:HDI Frequency BIT10: Current step of Multisteps BIT11:RTC time BIT12:inverter input terminals	0000~FFFF	0FFF	○	161.

Function Code	Name	Description	Factory Setting	Modify	Serial No	No.
		status BIT13:inverter output terminals status BIT14~ BIT15:reserved				
P7.09	Display coefficient of speed	0.1~999.9% Mechanical speed =120*Running frequency*P7.09/polar number	0.1~999.9%	100.0%	○	162.
P7.10	Display coefficient of line speed	0.1~999.9% Linear speed= Mechanical speed *P7.10	0.1~999.9%	1.0%	○	163.
P7.11	DSP software version			1.00	●	164.
P7.12	Accumulated running time	0~65535h		0	●	165.
P8 Fault record parameter group						

Function Code	Name	Description	Factory Setting	Modify	Serial No	No.
P8.00	Last two fault types	E00.mm Mm (Fault types): 00:No fault 01:Acceleration over voltage (E00.01) 02:Deceleration over current (E00.02) 03:Constant speed over current(E00.03) 04: Acceleration over voltage (E00.04) 05:deceleration over voltage (E00.05) 06: Constant speed over voltage (E00.06) 07:Grid undervoltage fault (E00.07) 08:Motor overload (E00.08) 09:Transformer overload (E00.09) 10:output phase lacking (E00.10) 11:Transformer overheating (E00.11) 12:External fault (E00.12) 13:485 communication fault (E00.13) 14:Current detecting fault (E00.14) 15:Motor autotuning fault (E00.15) 16:EEPROM Operation Fault (E00.16) 17:PID line off fault (E00.17) 18:Timer fault (E00.18)			•	166.

Function Code	Name	Description	Factory Setting	Modify	Serial No	No.
P8.01	Last time fault type				●	167.
P8.02	current fault type				●	168.
P8.03	Running frequency of current fault			0.00Hz	●	169.
P8.04	Output current of current fault			0.0A	●	170.
P8.05	DC bus voltage of current fault			0.0V	●	171.
P8.06	DC bus voltage of current fault unit			0	●	172.
P8.07	Temperature of current fault unit			0.0	●	173.
P8.08	Input terminal status of current fault			0	●	174.
P8.09	Output terminal status of current status			0	●	175.
P8.10	Time of current fault			00.00	●	176.
P9 PID control group						
P9.00	PID preset source selection	0: Keypad 1: AI1 2: AI2 3: AI3 4: AI1+AI2 5: AI2+AI3 6: AI1+AI3 7:HDI 8:Multi-step 9:Communication	0~9	0	○	177.
P9.01	Preset PID given	0.0%~100.0%	0.0~100.0	0.0%	○	178.
P9.02	PID feedback source selection	0: AI1 1: AI2 2: AI3 3: AI1+AI2 4: AI2+AI3 5: AI1+AI3 6: HDI 7:Communication	0~7	0	○	179.
P9.03	PID output characteristics	0: Positive 1: Negative	0~1	0	○	180.
P9.04	Proportional gain (Kp)	0.00~100.00	0.00~100.00	0.10	○	181.
P9.05	Integral time (Ti)	0.01~10.00s	0.01~10.00	0.10s	○	182.
P9.06	Differential time (Td)	0.00~10.00s	0.00~10.00	0.00s	○	183.
P9.07	Sampling cycle (T)	0.01~100.00s	0.01~100.00	0.50s	○	184.

Function Code	Name	Description	Factory Setting	Modify	Serial No	No.
P9.08	Bias limit	0.0~100.0%	0.0~100.0	0.0%	○	185.
P9.09	Feedback lost detecting value	0.0~100.0%	0.0~100.0%	0.0%	○	186.
P9.10	Feedback lost detecting time	0.0~3600.0s	0.0~3600.0	1.0s	○	187.
P9.11	PID dormancy wake up value	0.0~100.0%	0.0~100.0	0.0%	○	188.
P9.12	PID dormancy delay time	0.0~3600.0s	0.0~3600.0	0.0s	○	189.
PA Multi-steps control group						
PA.00	Multi-step speed 0	-100.0~100.0%	-100.0~100.0	0.0%	○	190.
PA.01	Multi-step speed 1	-100.0~100.0%	-100.0~100.0	0.0%	○	191.
PA.02	Multi-step speed 2	-100.0~100.0%	-100.0~100.0	0.0%	○	192.
PA.03	Multi-step speed 3	-100.0~100.0%	-100.0~100.0	0.0%	○	193.
PA.04	Multi-step speed 4	-100.0~100.0%	-100.0~100.0	0.0%	○	194.
PA.05	Multi-step speed 5	-100.0~100.0%	-100.0~100.0	0.0%	○	195.
PA.06	Multi-step speed 6	-100.0~100.0%	-100.0~100.0	0.0%	○	196.
PA.07	Multi-step speed 7	-100.0~100.0%	-100.0~100.0	0.0%	○	197.
PA.08	Multi-step speed 8	-100.0~100.0%	-100.0~100.0	0.0%	○	198.
PA.09	Multi-step speed 9	-100.0~100.0%	-100.0~100.0	0.0%	○	199.
PA.10	Multi-step speed 10	-100.0~100.0%	-100.0~100.0	0.0%	○	200.
PA.11	Multi-step speed 11	-100.0~100.0%	-100.0~100.0	0.0%	○	201.
PA.12	Multi-step speed 12	-100.0~100.0%	-100.0~100.0	0.0%	○	202.
PA.13	Multi-step speed 13	-100.0~100.0%	-100.0~100.0	0.0%	○	203.
PA.14	Multi-step speed 14	-100.0~100.0%	-100.0~100.0	0.0%	○	204.
PA.15	Multi-step speed 15	-100.0~100.0%	-100.0~100.0	0.0%	○	205.
PB Protection parameter group						
Pb.00	Reserved	Reserved			●	206.
Pb.01	Output phase-failure protection	0: Disabled 1: Enabled	0~1	1	○	207.

Function Code	Name	Description	Factory Setting	Modify	Serial No	No.
Pb.02	Motor overload protection	0: Disabled 1: Normal motor 2: Variable frequency motor	0~2	2	☉	208.
Pb.03	Motor overload protection current	20.0%~120.0%	20.0~120.0	100.0%	○	209.
Pb.04	Threshold of trip-free	70.0~110.0%	70.0~110.0	80.0%	○	210.
Pb.05	Decrease rate of trip-free	0.00Hz~P0.07	0.00Hz~P0.07	0.00Hz	○	211.
Pb.06	Over-voltage stall protection	0: Disabled 1: Enabled	0~1	0	○	212.
Pb.07	Over-voltage stall protection point	105~140%	105~140	120%	○	213.
Pb.08	Over-current protection	0: Disabled 1: Enabled	0~1	0	○	214.
Pb.09	Over-current stall threshold	50~200%	50~200	120%	○	215.
Pb.10	Input overvoltage pre-warning threshold	105~125%	105~125	110%	○	216.
Pb.11	Unit bypass function	0:maunal bypass 1:auto bypass	0~1	0	○	217.
Pb.12	Unit manual bypass bit selection	0x000~0x1FF	000~1FF		○	218.
Pb.13	hardware overcurrnet threshold	50~200%(inverter rated current)	50~200	150%	☉	219.
Pb.14	Power frequency bypass bypass when failure	0>manual power frequency bypass 1:Auto power frequency bypass	0~1	0	○	220.
Pb.15	Reserved				●	221.
Pb.16	Reserved				●	222.
Pb.17	Reserved				●	223.
PC serial communication group						
PC.00	Local address	1~247	1~247	1	○	224.
PC.01	Baud rate selection	0:1200BPS 1:2400BPS 2:4800BPS	0~5	4	○	225.

Function Code	Name	Description	Factory Setting	Modify	Serial No	No.
		3:9600BPS 4:19200BPS 5:38400BPS				
PC.02	Data format	0: RTU, 1 start bit, 8 data bits, no parity check, 1 stop bit. 1: RTU, 1 start bit, 8 data bits, even parity check, 1 stop bit. 2: RTU, 1 start bit, 8 data bits, odd parity check, 1 stop bit. 3: RTU, 1 start bit, 8 data bits, no parity check, 2 stop bits. 4: RTU, 1 start bit, 8 data bits, even parity check, 2 stop bits. 5: RTU, 1 start bit, 8 data bits, odd parity check, 2 stop bits. 6: ASCII, 1 start bit, 7 data bits, no parity check, 1 stop bit. 7: ASCII, 1 start bit, 7 data bits, even parity check, 1 stop bit. 8: ASCII, 1 start bit, 7 data bits, odd parity check, 1 stop bit. 9: ASCII, 1 start bit, 7 data bits, no parity check, 2 stop bits. 10: ASCII, 1 start bit, 7 data bits, even parity check, 2 stop bits. 11: ASCII, 1 start bit, 7 data bits, odd parity check, 2 stop bits. 12: ASCII, 1 start bit, 8 data bits, no parity check, 1 stop bit. 13: ASCII, 1 start bit, 8 data bits, even parity check, 1 stop bit. 14: ASCII, 1 start bit, 8 data bits, odd parity check, 1 stop bit. 15: ASCII, 1 start bit, 8 data bits, no parity check, 2 stop bits. 16: ASCII, 1 start bit, 8 data bits, even parity check, 2 stop bits. 17: ASCII, 1 start bit, 8 data bits, odd parity check, 2 stop bits.	0~5	1	○	226.
PC.03	Communication delay time	0~200ms	0~200	5	○ ●	
PC.04	Communication timeout delay	0.0 invalid,	0.0~100.0	0.0s	○	227.

Function Code	Name	Description	Factory Setting	Modify	Serial No	No.
		0.1~100.0s				
PC.05	Communication error action	0: Alarm and coast to stop 1: No alarm and continue to run 2: No alarm but stop according to P1.06 (if P0.03=2) 3: No alarm but stop according to P1.06	0~3	1	○ ●	
PC.06	Response action	Unit's place of LED 0: Response to writing 1: No response to writing Ten's place of LED 0: Reference not saved when power off 1:Reference saved when power off	0x000~0x111	000	○	228.
PC.07	Reserved				●	229.
PD Unit status query function group						
Pd.00	A-Phase effective unit indication	0x000~0x1FF	000~1FF		●	230.
Pd.01	B-phase effective unit indication	0x000~0x1FF	000~1FF		●	231.
Pd.02	C-phase effective unit indication	0x000~0x1FF	000~1FF		●	232.
Pd.03	Unit A1 temperature indication	0.0~100.0℃	0.0~100.0		●	233.
Pd.04	Unit A2 temperature indication	0.0~100.0℃	0.0~100.0		●	234.
Pd.05	Unit A3 temperature indication	0.0~100.0℃	0.0~100.0		●	235.
Pd.06	Unit A4 temperature indication	0.0~100.0℃	0.0~100.0		●	236.
Pd.07	Unit A5 temperature indication	0.0~100.0℃	0.0~100.0		●	237.
Pd.08	Unit A6 temperature indication	0.0~100.0℃	0.0~100.0		●	238.
Pd.09	Unit A7 temperature indication	0.0~100.0℃	0.0~100.0		●	239.
Pd.10	Unit A8 temperature indication	0.0~100.0℃	0.0~100.0		●	240.
Pd.11	Unit A9 temperature indication	0.0~100.0℃	0.0~100.0		●	241.
Pd.12	Unit B1 temperature indication	0.0~100.0℃	0.0~100.0		●	242.
Pd.13	Unit B2 temperature indication	0.0~100.0℃	0.0~100.0		●	243.

Function Code	Name	Description	Factory Setting	Modify	Serial No	No.
Pd.14	Unit B3 temperature indication	0.0~100.0℃	0.0~100.0		•	244.
Pd.15	Unit B4 temperature indication	0.0~100.0℃	0.0~100.0		•	245.
Pd.16	Unit B5 temperature indication	0.0~100.0℃	0.0~100.0		•	246.
Pd.17	Unit B6 temperature indication	0.0~100.0℃	0.0~100.0		•	247.
Pd.18	Unit B7 temperature indication	0.0~100.0℃	0.0~100.0		•	248.
Pd.19	Unit B8 temperature indication	0.0~100.0℃	0.0~100.0		•	249.
Pd.20	Unit B9 temperature indication	0.0~100.0℃	0.0~100.0		•	250.
Pd.21	Unit C1 temperature indication	0.0~100.0℃	0.0~100.0		•	251.
Pd.22	Unit C2 temperature indication	0.0~100.0℃	0.0~100.0		•	252.
Pd.23	Unit C3 temperature indication	0.0~100.0℃	0.0~100.0		•	253.
Pd.24	Unit C4 temperature indication	0.0~100.0℃	0.0~100.0		•	254.
Pd.25	Unit C5 temperature indication	0.0~100.0℃	0.0~100.0		•	255.
Pd.26	Unit C6 temperature indication	0.0~100.0℃	0.0~100.0		•	256.
Pd.27	Unit C7 temperature indication	0.0~100.0℃	0.0~100.0		•	257.
Pd.28	Unit C8 temperature indication	0.0~100.0℃	0.0~100.0		•	258.
Pd.29	Unit C9 temperature indication	0.0~100.0℃	0.0~100.0		•	259.
Pd.30	Unit A1 DC bus voltage indication	0~2000V	0~2000		•	260.
Pd.31	Unit A2 DC bus voltage indication	0~2000V	0~2000		•	261.
Pd.32	Unit A3 DC bus voltage indication	0~2000V	0~2000		•	262.
Pd.33	Unit A4 DC bus voltage indication	0~2000V	0~2000		•	263.
Pd.34	Unit A5 DC bus voltage indication	0~2000V	0~2000		•	264.
Pd.35	Unit A6 DC bus voltage indication	0~2000V	0~2000		•	265.
Pd.36	Unit A7 DC bus voltage indication	0~2000V	0~2000		•	266.
Pd.37	Unit A8 DC bus voltage indication	0~2000V	0~2000		•	267.

Function Code	Name	Description	Factory Setting	Modify	Serial No	No.
Pd.38	Unit A9 DC bus voltage indication	0~2000V	0~2000		•	268.
Pd.39	Unit B1 DC bus voltage indication	0~2000V	0~2000		•	269.
Pd.40	Unit B2 DC bus voltage indication	0~2000V	0~2000		•	270.
Pd.41	Unit B3 DC bus voltage indication	0~2000V	0~2000		•	271.
Pd.42	Unit B4 DC bus voltage indication	0~2000V	0~2000		•	272.
Pd.43	Unit B5 DC bus voltage indication	0~2000V	0~2000		•	273.
Pd.44	Unit B6 DC bus voltage indication	0~2000V	0~2000		•	274.
Pd.45	Unit B7 DC bus voltage indication	0~2000V	0~2000		•	275.
Pd.46	Unit B8 DC bus voltage indication	0~2000V	0~2000		•	276.
Pd.47	Unit B9 DC bus voltage indication	0~2000V	0~2000		•	277.
Pd.48	Unit C1 DC bus voltage indication	0~2000V	0~2000		•	278.
Pd.49	Unit C2 DC bus voltage indication	0~2000V	0~2000		•	279.
Pd.50	Unit C3 DC bus voltage indication	0~2000V	0~2000		•	280.
Pd.51	Unit C4 DC bus voltage indication	0~2000V	0~2000		•	281.
Pd.52	Unit C5 DC bus voltage indication	0~2000V	0~2000		•	282.
Pd.53	Unit C6 DC bus voltage indication	0~2000V	0~2000		•	283.
Pd.54	Unit C7 DC bus voltage indication	0~2000V	0~2000		•	284.
Pd.55	Unit C8 DC bus voltage indication	0~2000V	0~2000		•	285.
Pd.56	Unit C9 DC bus voltage indication	0~2000V	0~2000		•	286.
Pd.57	Unit A1 fault indicated value	0x0000~0xFFFF	0000~FFFF		•	287.
Pd.58	Unit A2 fault indicated value	0x0000~0xFFFF	0000~FFFF		•	288.
Pd.59	Unit A3 fault indicated value	0x0000~0xFFFF	0000~FFFF		•	289.
Pd.60	Unit A4 fault indicated value	0x0000~0xFFFF	0000~FFFF		•	290.
Pd.61	Unit A5 fault indicated value	0x0000~0xFFFF	0000~FFFF		•	291.

Function Code	Name	Description	Factory Setting	Modify	Serial No	No.
Pd.62	Unit A6 fault indicated value	0x0000~0xFFFF	0000~FFFF		•	292.
Pd.63	Unit A7 fault indicated value	0x0000~0xFFFF	0000~FFFF		•	293.
Pd.64	Unit A8 fault indicated value	0x0000~0xFFFF	0000~FFFF		•	294.
Pd.65	Unit A9 fault indicated value	0x0000~0xFFFF	0000~FFFF		•	295.
Pd.66	Unit B1 fault indicated value	0x0000~0xFFFF	0000~FFFF		•	296.
Pd.67	Unit B2 fault indicated value	0x0000~0xFFFF	0000~FFFF		•	297.
Pd.68	Unit B3 fault indicated value	0x0000~0xFFFF	0000~FFFF		•	298.
Pd.69	Unit B4 fault indicated value	0x0000~0xFFFF	0000~FFFF		•	299.
Pd.70	Unit B5 fault indicated value	0x0000~0xFFFF	0000~FFFF		•	300.
Pd.71	Unit B6 fault indicated value	0x0000~0xFFFF	0000~FFFF		•	301.
Pd.72	Unit B7 fault indicated value	0x0000~0xFFFF	0000~FFFF		•	302.
Pd.73	Unit B8 fault indicated value	0x0000~0xFFFF	0000~FFFF		•	303.
Pd.74	Unit B9 fault indicated value	0x0000~0xFFFF	0000~FFFF		•	304.
Pd.75	Unit C1 fault indicated value	0x0000~0xFFFF	0000~FFFF		•	305.
Pd.76	Unit C2 fault indicated value	0x0000~0xFFFF	0000~FFFF		•	306.
Pd.77	Unit C3 fault indicated value	0x0000~0xFFFF	0000~FFFF		•	307.
Pd.78	Unit C4 fault indicated value	0x0000~0xFFFF	0000~FFFF		•	308.
Pd.79	Unit C5 fault indicated value	0x0000~0xFFFF	0000~FFFF		•	309.
Pd.80	Unit C6 fault indicated value	0x0000~0xFFFF	0000~FFFF		•	310.
Pd.81	Unit C7 fault indicated value	0x0000~0xFFFF	0000~FFFF		•	311.
Pd.82	Unit C8 fault indicated value	0x0000~0xFFFF	0000~FFFF		•	312.
Pd.83	Unit C9 fault indicated value	0x0000~0xFFFF	0000~FFFF		•	313.
PE factory function group						
