

A Wealth of Models for All Types of Applications

- Easy installation, high-speed pulse generator, high-speed rotation control, and more.
- Direct mounted to metal (-N Models).
- A wealth of models ideal for limit control, counting control, and other applications (-N Models).



Be sure to read *Safety Precautions* on page 9.

Ordering Information

Sensors [Refer to *Dimensions* on page 10.]

DC 2-Wire Models

| Appearance | Sensing distance | | Model | |
|----------------|------------------|-------|----------------|--------------|
| | | | Operation mode | |
| | | | NO | NC |
| Unshielded | 17 × 17 | 5 mm | TL-Q5MD1 2M | TL-Q5MD2 2M |
| | 25 × 25 | 7 mm | TL-N7MD1 2M | TL-N7MD2 2M |
| | 30 × 30 | 12 mm | TL-N12MD1 2M | TL-N12MD2 2M |
| | 40 × 40 | 20 mm | TL-N20MD1 2M | TL-N20MD2 2M |

Note: Models with a different frequency are available to prevent mutual interference. The model numbers are TL-N□MD□5 and TL-Q5MD□5 (e.g., TL-N7MD15).

DC 3-Wire and AC 2-Wire Models

| Appearance | Sensing distance | | Output configuration | Model | |
|----------------|------------------|----------------|----------------------|--------------------|-----------------|
| | | | | Operation mode | |
| | | | | NO | NC |
| Unshielded | 8 × 9 | 2 mm | DC 3-wire, NPN | TL-Q2MC1 2M | — |
| | 17 × 17 | 5 mm | | TL-Q5MC1 2M *2 | TL-Q5MC2 2M |
| | 25 × 25 | 5 mm | DC 3-wire, NPN | TL-N5ME1 2M *1 *2 | TL-N5ME2 2M *1 |
| | | | AC 2-wire | TL-N5MY1 2M | TL-N5MY2 2M |
| | 30 × 30 | 10 mm | DC 3-wire, NPN | TL-N10ME1 2M *1 *2 | TL-N10ME2 2M *1 |
| | | | AC 2-wire | TL-N10MY1 2M | TL-N10MY2 2M |
| | 40 × 40 | 20 mm | DC 3-wire, NPN | TL-N20ME1 2M *1 *2 | TL-N20ME2 2M |
| | | | AC 2-wire | TL-N20MY1 2M | TL-N20MY2 2M |
| Grooved | 7.5 mm | DC 3-wire, NPN | TL-G3D-3 1M | — | |

Note: Models with a different frequency are available to prevent mutual interference. Models numbers for Sensors with different frequencies are TL-□□M□□5 (example: TL-N5ME15).

*1. Models are also available with 5-m cables. Add the cable length to the model number (example: TL-N5ME1 5M).

*2. Models with robotics cables are also available. Add -R to the end of the model number (example: TL-N5ME1-R).

Accessories (Order Separately)

Mounting Brackets A Mounting Bracket is provided with the Sensor depending on the model number. Check the column for the applicable Sensor.
[Refer to Dimensions on page 12.]

| Type | Model | Applicable Sensors | |
|--------------------------------|-------------|-----------------------------|----------------------|
| | | Provided with these Sensors | Order separately |
| Mounting Brackets | Y92E-C5 | TL-N5ME□, TL-N7MD□ | TL-N5MY□ |
| | Y92E-C10 | TL-N10ME□, TL-N12MD□ | TL-N10MY□ |
| | Y92E-C20 | TL-N20ME□, TL-N20MD□ | TL-N20MY□ |
| Mounting Brackets for Conduits | Y92E-N5C15 | --- | TL-N5ME□, TL-N5MY□ |
| | Y92E-N10C15 | --- | TL-N10ME□, TL-N10MY□ |

Ratings and Specifications

DC 2-Wire Models

| Item | Model | TL-Q5MD□ | TL-N7MD□ | TL-N12MD□ | TL-N20MD□ |
|---|-------------------------|--|--|--|--|
| Sensing distance | | 5 mm ±10% | 7 mm ±10% | 12 mm ±10% | 20 mm ±10% |
| Set distance | | 0 to 4 mm | 0 to 5.6 mm | 0 to 9.6 mm | 0 to 16 mm |
| Differential travel | | 10% max. of sensing distance | | | |
| Detectable object | | Ferrous metal (The sensing distance decreases with non-ferrous metal. Refer to <i>Engineering Data</i> on page 5.) | | | |
| Standard sensing object | | Iron, 18 × 18 × 1 mm | Iron, 30 × 30 × 1 mm | Iron, 40 × 40 × 1 mm | Iron, 50 × 50 × 1 mm |
| Response frequency * | | 500 Hz | | | 300 Hz |
| Power supply voltage (operating voltage range) | | 12 to 24 VDC (10 to 30 VDC), ripple (p-p): 10% max. | | | |
| Leakage current | | 0.8 mA max. | | | |
| Control output | Load current | 3 to 100 mA | | | |
| | Residual voltage | 3.3 V max. (Load current: 100 mA, Cable length: 2 m) | | | |
| Indicators | | D1 Models: Operation indicator (red), Setting indicator (green) D2 Models: Operation indicator (red) | | | |
| Operation mode (with sensing object approaching) | | D1 Models: NO D2 Models: NC Refer to the timing charts under <i>I/O Circuit Diagrams</i> on page 7 for details. | | | |
| Protection circuits | | Load short-circuit protection, Surge suppressor | | | |
| Ambient temperature range | | Operating/Storage: -25 to 70°C (with no icing or condensation) | | | |
| Ambient humidity range | | Operating/Storage: 35% to 95% (with no condensation) | | | |
| Temperature influence | | ±10% max. of sensing distance at 23°C in the temperature range of -25 to 70°C | | | |
| Voltage influence | | ±2.5% max. of sensing distance at rated voltage in the rated voltage ±15% range | | | |
| Insulation resistance | | 50 MΩ min. (at 500 VDC) between current-carrying parts and case | | | |
| Dielectric strength | | 1,000 VAC for 1 min between current-carrying parts and case | | | |
| Vibration resistance | | Destruction: 10 to 55 Hz, 1.5-mm double amplitude for 2 hours each in X, Y, and Z directions | | | |
| Shock resistance | | Destruction: 500 m/s ² 3 times each in X, Y, and Z directions | Destruction: 1,000 m/s ² 10 times each in X, Y, and Z directions | | |
| Degree of protection | | IEC 60529 IP67, in-house standards: oil-resistant | | | |
| Connection method | | Pre-wired Models (Standard cable length: 2 m) | | | |
| Weight (packed state) | | Approx. 45 g | Approx. 145 g | Approx. 170 g | Approx. 240 g |
| Materials | Case | Heat-resistant ABS | | | |
| | Sensing surface | | | | |
| Accessories | | Instruction manual | Mounting Bracket, Mounting phillips screws (M4 × 25), Instruction manual | Mounting Bracket, Mounting phillips screws (M4 × 30), Instruction manual | Mounting Bracket, Mounting phillips screws (M5 × 40), Instruction manual |

* The response frequency is an average value.

Measurement conditions are as follows: standard sensing object, a distance of twice the standard sensing object, and a set distance of half the sensing distance.

DC 3-Wire Models

| Item | Model | TL-Q2MC1 | TL-Q5MC□ | TL-G3D-3 |
|--|------------------|--|---|---|
| Sensing distance | | 2 mm ±15% | 5 mm ±10% | 7.5±0.5mm |
| Set distance | | 0 to 1.5 mm | 0 to 4 mm | 10 mm |
| Differential travel | | 10% max. of sensing distance | | |
| Detectable object | | Ferrous metal (The sensing distance decreases with non-ferrous metal. Refer to <i>Engineering Data</i> on page 6.) | | |
| Standard sensing object | | Iron, 8 × 8 × 1 mm | Iron, 15 × 15 × 1 mm | Iron, 10 × 5 × 0.5mm |
| Response time | | --- | 2 ms max. | 1 ms max. |
| Response frequency * | | 500 Hz | | |
| Power supply voltage (operating voltage range) | | 12 to 24 VDC (10 to 30 VDC), ripple (p-p): 10% max. | | 12 to 24 VDC, ripple (p-p): 5% max. |
| Current consumption | | 15 mA max. at 24 VDC (no-load) | 10 mA max. at 24 VDC | 2 mA max. at 24 VDC (no-load) |
| Control output | Load current | NPN open collector 100 mA max. at 30 VDC max. | NPN open collector 50 mA max. at 30 VDC max. | NPN transistor output 20 mA max. |
| | Residual voltage | 1 V max. (under load current of 100 mA with cable length of 2 m) | 1 V max. (under load current of 50 mA with cable length of 2 m) | --- |
| Indicators | | Detection indicator (red) | | --- |
| Operation mode (with sensing object approaching) | | NO | C1 Models: NO C2 Models: NC | NO |
| | | Refer to the timing charts under <i>I/O Circuit Diagrams</i> on page 7 for details. | | |
| Protection circuits | | Reverse polarity protection, Surge suppressor | | Surge suppressor |
| Ambient temperature range | | Operating/Storage: -10 to 60°C (with no icing or condensation) | Operating/Storage: -25 to 70°C (with no icing or condensation) | |
| Ambient humidity range | | Operating/Storage: 35% to 95% (with no condensation) | | |
| Temperature influence | | ±10% max. of sensing distance at 23°C in the temperature range of -10 to 60°C | ±20% max. of sensing distance at 23°C in the temperature range of -25 to 70°C | ±10% max. of sensing distance at 23°C in the temperature range of -10 to 55°C |
| Voltage influence | | ±2.5% max. of sensing distance at rated voltage in rated voltage ±10% range | | |
| Insulation resistance | | 50 MΩ min. (at 500 VDC) between current-carrying parts and case | 5 MΩ min. (at 500 VDC) between current-carrying parts and case | |
| Dielectric strength | | 1,000 VAC for 1 min between current-carrying parts and case | 500 VAC, 50/60 Hz for 1 min between current-carrying parts and case | |
| Vibration resistance | | Destruction: 10 to 55 Hz, 1.5-mm double amplitude for 2 hours each in X, Y, and Z directions | | |
| Shock resistance | | Destruction: 1,000 m/s ² 10 times each in X, Y, and Z directions | Destruction: 200 m/s ² 10 times each in X, Y, and Z directions | |
| Degree of protection | | IEC 60529 IP67, in-house standards: oil-resistant | IEC IP67 | IEC IP66 |
| Connection method | | Pre-wired Models (Standard cable length: 2 m) | | Pre-wired Models (Standard cable length: 1m) |
| Weight (packed state) | | Approx. 30 g | Approx. 60 g | Approx. 30 g |
| Materials | Case | Heat-resistant ABS | | PPO, etc. (Refer to page 11) |
| | Sensing surface | | | |
| Accessories | | Instruction manual | --- | |

* The response frequency is an average value. Measurement conditions are as follows: standard sensing object, a distance of twice the standard sensing object, and a set distance of half the sensing distance.

| Item | Model | TL-N5ME□, TL-N5MY□ | TL-N10ME□, TL-N10MY□ | TL-N20ME□, TL-N20MY□ |
|--|-------------------------|--|--|--|
| Sensing distance | | 5 mm ±10% | 10 mm ±10% | 20 mm ±10% |
| Set distance | | 0 to 4 mm | 0 to 8 mm | 0 to 16 mm |
| Differential travel | | 15% max. of sensing distance | | |
| Detectable object | | Ferrous metal (The sensing distance decreases with non-ferrous metal. Refer to <i>Engineering Data</i> on pages 6 and 7.) | | |
| Standard sensing object | | Iron, 30 × 30 × 1 mm | Iron, 40 × 40 × 1 mm | Iron, 50 × 50 × 1 mm |
| Response frequency *1 | | E Models: 500 Hz Y Models: 10 Hz | | E Models: 40 Hz Y Models: 10 Hz |
| Power supply voltage *2 (operating voltage range) | | E Models: 12 to 24 VDC (10 to 30 VDC), ripple (p-p): 10% max. Y Models: 100 to 220 VAC (90 to 250 VAC), 50/60 Hz | | |
| Current consumption | | E Models: 8 mA max. at 12 VDC, 15 mA max. at 24 VDC | | |
| Leakage current | | Y Models: Refer to <i>Engineering Data</i> on page 5. | | |
| Control output | Load current | E Models: 100 mA max. at 12 VDC, 200 mA max. at 24 VDC Y Models: 10 to 200 mA | | |
| | Residual voltage | E Models: 1 V max. (load current: 200 mA) Y Models: Refer to <i>Engineering Data</i> on page 5. | | |
| Indicators | | E Models: Detection indicator (red) Y Models: Operation indicator (red) | | |
| Operation mode (with sensing object approaching) | | E1/Y1 Models: NO E2/Y2 Models: NC Refer to the timing charts under <i>I/O Circuit Diagrams</i> on page 8 for details. | | |
| Protection circuits | | E Models: Reverse polarity protection, Surge suppressor Y Models: Surge suppressor | | |
| Ambient temperature range | | Operating/Storage: -25 to 70°C (with no icing or condensation) | | |
| Ambient humidity range | | Operating/Storage: 35% to 95% (with no condensation) | | |
| Temperature influence | | ±10% max. of sensing distance at 23°C in the temperature range of -25 to 70°C | | |
| Voltage influence | | E Models: ±2.5% max. of sensing distance at rated voltage in rated voltage ±10% range Y Models: ±1% max. of sensing distance at rated voltage in rated voltage ±10% range | | |
| Insulation resistance | | 50 MΩ min. (at 500 VDC) between current-carrying parts and case | | |
| Dielectric strength | | E Models: 1,000 VAC, 50/60 Hz for 1 min between current-carrying parts and case Y Models: 2,000 VAC, 50/60 Hz for 1 min between current-carrying parts and case | | |
| Vibration resistance | | Destruction: 10 to 55 Hz, 1.5-mm double amplitude for 2 hours each in X, Y, and Z directions | | |
| Shock resistance | | Destruction: 500 m/s ² 10 times each in X, Y, and Z directions | | |
| Degree of protection | | IEC 60529 IP67, in-house standards: oil-resistant | | |
| Connection method | | Pre-wired Models (Standard cable length: 2 m) | | |
| Weight (packed state) | | Approx. 145 g | Approx. 170 g | Approx. 240 g |
| Materials | Case | Heat-resistant ABS | | |
| | Sensing surface | | | |
| Accessories | | E Models: Mounting Bracket, Mounting phillips screws (M4 × 25), Instruction manual Y Models: Instruction manual | E Models: Mounting Bracket, Mounting phillips screws (M4 × 30), Instruction manual Y Models: Instruction manual | E Models: Mounting Bracket, Mounting phillips screws (M5 × 40), Instruction manual Y Models: Instruction manual |

*1. The response frequency is an average value. Measurement conditions are as follows: standard sensing object, a distance of twice the standard sensing object, and a set distance of half the sensing distance.

*2. E Models (DC switching models): A full-wave rectification power supply of 24 VDC ±10% (average value) can be used.

Engineering Data (Typical)

Sensing Area

TL-Q2MC1

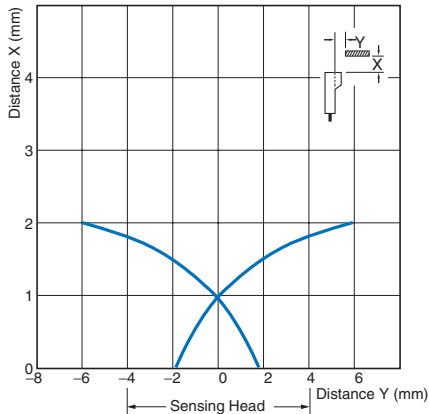

TL-Q5M□□

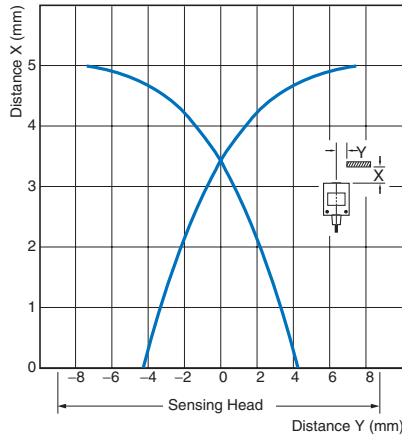

TL-N□ME□
TL-N□MY□

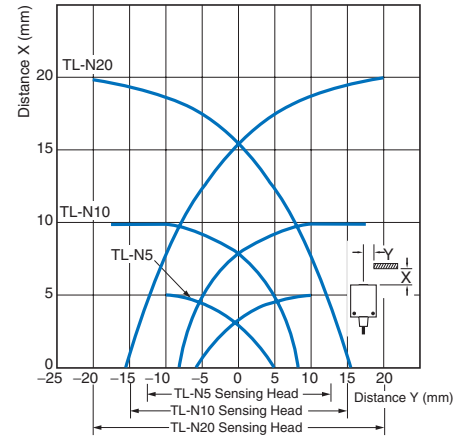

TL-N□MD□

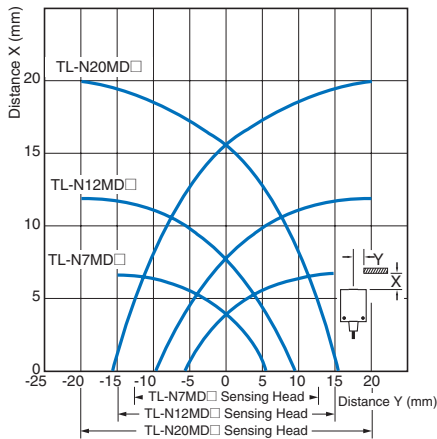

Leakage Current

TL-N□MY

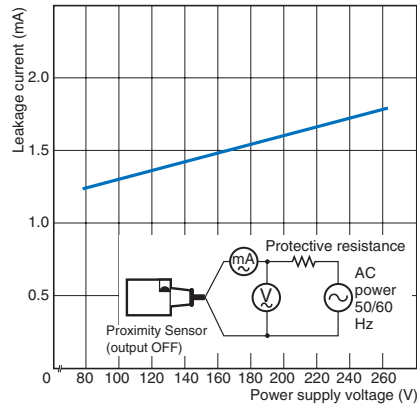

Residual Output Voltage

TL-N□MD

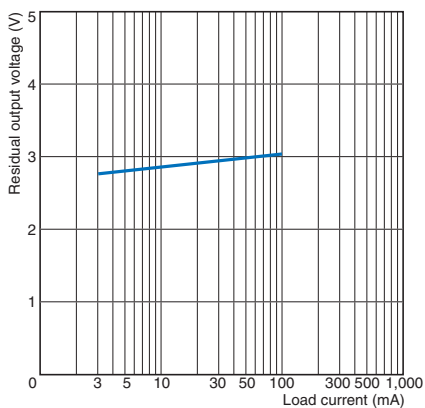

TL-N□MY at 100 VAC

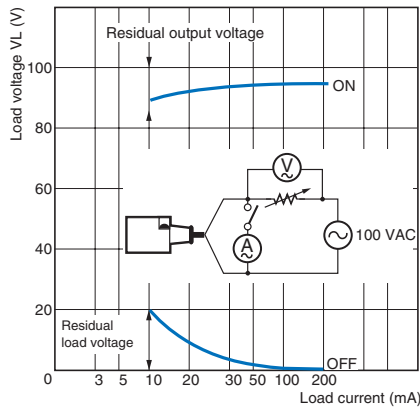

TL-N□MY at 200 VAC

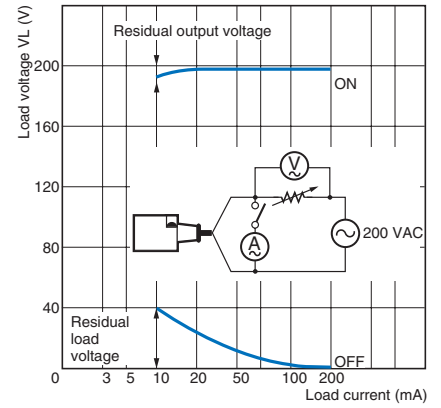

Thickness of Sensing Object vs. Sensing Distance

TL-G3D-3

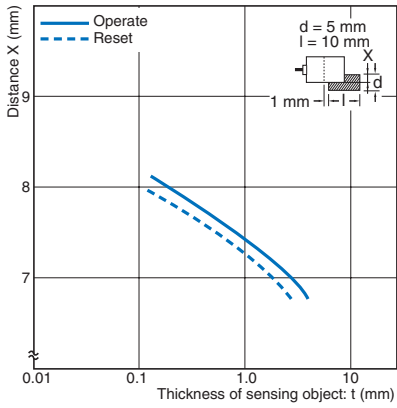

Sensing Object Size vs. Sensing Distance

TL-Q5MC

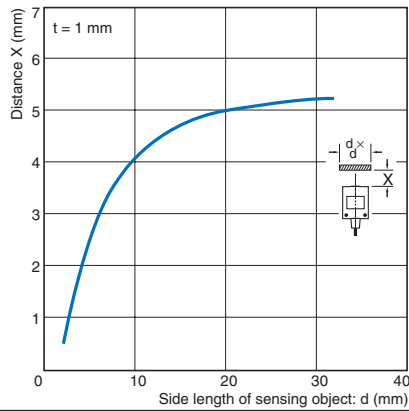

TL-G3D-3

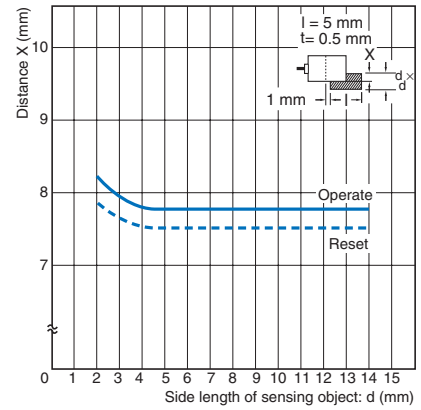

Influence of Sensing Object Size and Material

TL-Q2MC1

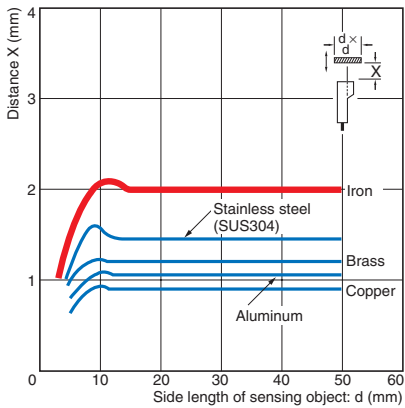

TL-Q5M

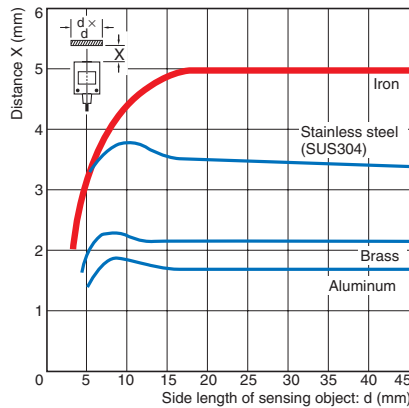

TL-N5

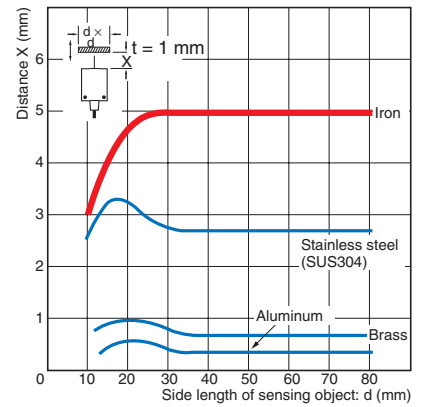

TL-N7MD

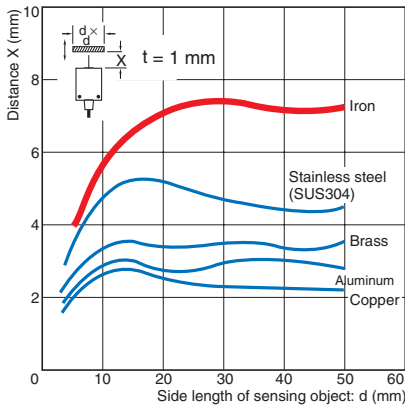

TL-N12MD

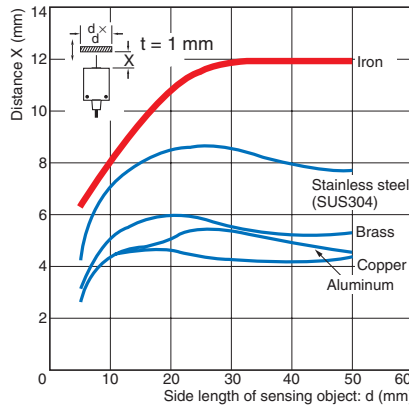

TL-N20MD

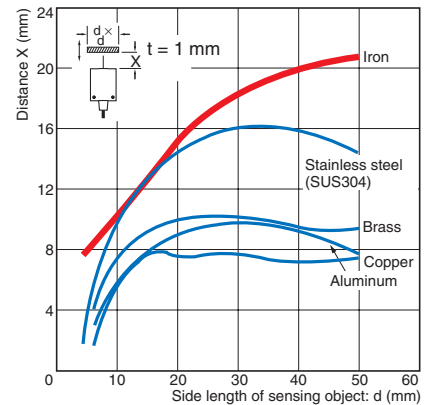

TL-N10□

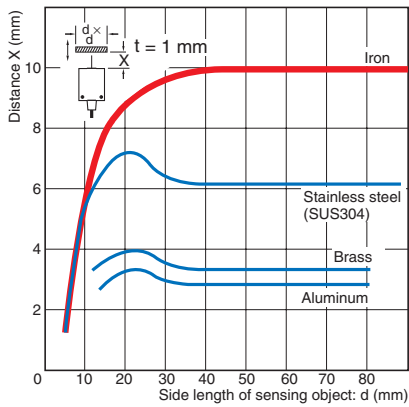

TL-N20□

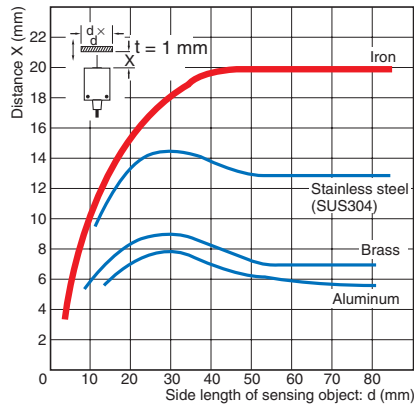



I/O Circuit Diagrams

DC 2-Wire Models

| Operation mode | Model | Timing chart | Output circuit |
|----------------|--|---|--|
| NO | TL-Q5MD1 TL-N7MD1 TL-N12MD1 TL-N20MD1 | <p>Non-sensing area Unstable sensing area Stable sensing area</p> <p>Sensing object</p> <p>(%) 100 80 (TYP) 0</p> <p>Rated sensing distance</p> <p>ON Setting indicator (green) OFF</p> <p>ON Operation indicator (red) OFF</p> <p>ON Control output OFF</p> | <p>Note: The load can be connected to either the +V or 0 V side.</p> |
| NC | TL-Q5MD2 TL-N7MD2 TL-N12MD2 TL-N20MD2 | <p>Non-sensing area Sensing area</p> <p>Sensing object</p> <p>(%) 100 0</p> <p>Rated sensing distance</p> <p>ON Operation indicator (red) OFF</p> <p>ON Control output OFF</p> | |

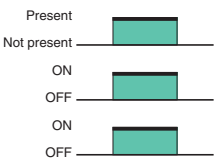
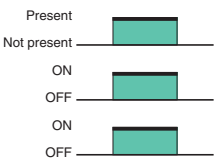
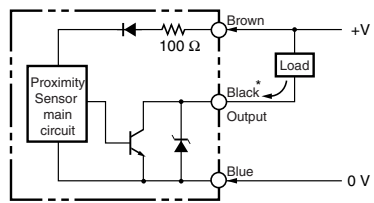
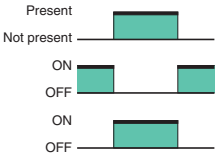
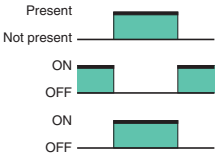
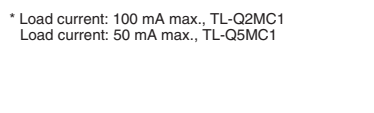
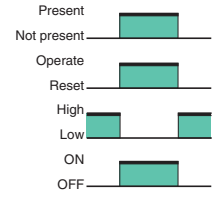
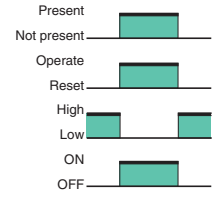
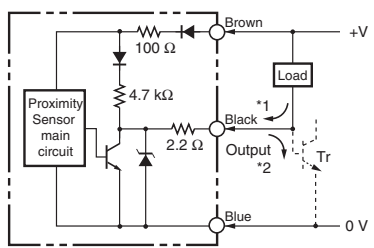
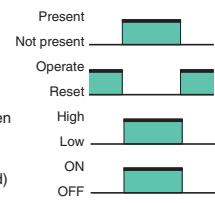
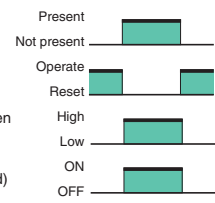
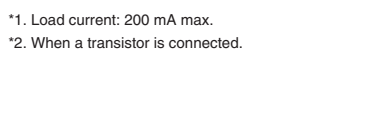
DC 3-Wire Models

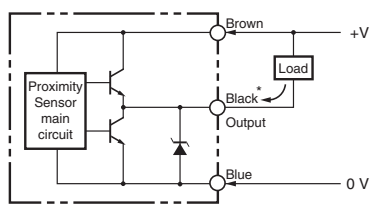
| Operation mode | Model | Timing chart | Output circuit |
|-------------------|------------------------------------|--|---|
| NO | TL-Q2MC1 TL-Q5MC1 | <p>Sensing object</p> <p>Present </p> <p>Not present </p> <p>Output transistor (load)</p> <p>ON</p> <p>OFF</p> <p>Detection indicator (red)</p> <p>ON</p> <p>OFF</p> |  <p>* Load current: 100 mA max., TL-Q2MC1 Load current: 50 mA max., TL-Q5MC1</p> |
| NC | TL-Q5MC2 | <p>Sensing object</p> <p>Present </p> <p>Not present </p> <p>Output transistor (load)</p> <p>ON</p> <p>OFF</p> <p>Detection indicator (red)</p> <p>ON</p> <p>OFF</p> |  <p>* Load current: 100 mA max., TL-Q2MC1 Load current: 50 mA max., TL-Q5MC1</p> |
| NO | TL-N5ME1 TL-N10ME1 TL-N20ME1 | <p>Sensing object</p> <p>Present </p> <p>Not present </p> <p>Load (between brown and black leads)</p> <p>Operate</p> <p>Reset</p> <p>High</p> <p>Low</p> <p>Output voltage (between black and blue leads)</p> <p>High</p> <p>Low</p> <p>Detection indicator (red)</p> <p>ON</p> <p>OFF</p> |  <p>*1. Load current: 200 mA max. *2. When a transistor is connected.</p> |
| NC | TL-N5ME2 TL-N10ME2 TL-N20ME2 | <p>Sensing object</p> <p>Present </p> <p>Not present </p> <p>Load (between brown and black leads)</p> <p>Operate</p> <p>Reset</p> <p>High</p> <p>Low</p> <p>Output voltage (between black and blue leads)</p> <p>High</p> <p>Low</p> <p>Detection indicator (red)</p> <p>ON</p> <p>OFF</p> |  <p>*1. Load current: 200 mA max. *2. When a transistor is connected.</p> |
| Transistor output | TL-G3D-3 | <p>Sensing object</p> <p>Present </p> <p>Not present </p> <p>Output transistor (load)</p> <p>ON</p> <p>OFF</p> |  <p>* Load current: 20 mA max.</p> |

AC 2-Wire Models

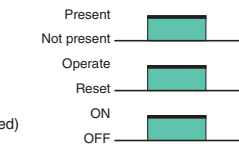
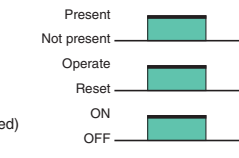
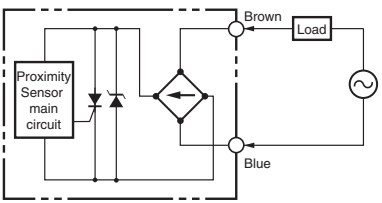
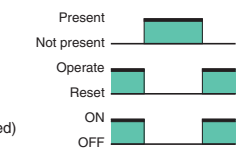
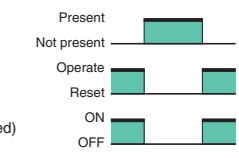
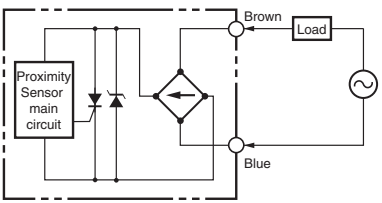
| Operation mode | Model | Timing chart | Output circuit |
|----------------|------------------------------------|--|---|
| NO | TL-N5MY1 TL-N10MY1 TL-N20MY1 | <p>Sensing object</p> <p>Present </p> <p>Not present </p> <p>Load</p> <p>Operate</p> <p>Reset</p> <p>ON</p> <p>OFF</p> <p>Operation indicator (red)</p> <p>ON</p> <p>OFF</p> |  |
| NC | TL-N5MY2 TL-N10MY2 TL-N20MY2 | <p>Sensing object</p> <p>Present </p> <p>Not present </p> <p>Load</p> <p>Operate</p> <p>Reset</p> <p>ON</p> <p>OFF</p> <p>Operation indicator (red)</p> <p>ON</p> <p>OFF</p> |  |

Safety Precautions

Refer to *Warranty and Limitations of Liability*.

⚠ WARNING

This product is not designed or rated for ensuring safety of persons either directly or indirectly. Do not use it for such purposes.



- Do not short-circuit the load, otherwise the Sensor may be damaged.
- Do not supply power to the Sensor with no load, otherwise the Sensor may be damaged.
Applicable Models: AC 2-Wire Models



Precautions for Correct Use

Do not use this product under ambient conditions that exceed the ratings.

● Design

Influence of Surrounding Metal

When mounting the Sensor within a metal panel, ensure that the clearances given in the following table are maintained. Failure to maintain these distances may cause deterioration in the performance of the Sensor.

Rectangular Models TL-N*2

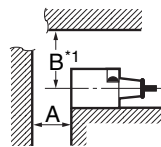

TL-Q

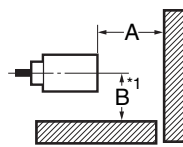

Influence of Surrounding Metal (Unit: mm)

| Model | Distance | A | B *1 |
|----------------------|----------|----|------|
| TL-Q5M□□ | | 20 | 20 |
| TL-N7MD□ | | 40 | 35 |
| TL-N12MD□ | | 50 | 40 |
| TL-N20MD□ | | 70 | 60 |
| TL-N5ME□, TL-N5MY□ | | 20 | 23 |
| TL-N10ME□, TL-N10MY□ | | 40 | 30 |
| TL-N20ME□, TL-N20MY□ | | 80 | 45 |

*1. Dimension B is the same value as the value on the sides and the top. (The construction is symmetric around a point.)

*2. The values for A or B for the TL-N apply when there is metal on only one side of the sensor. If there is metal on two or more sides, the value must be multiplied by two or more.

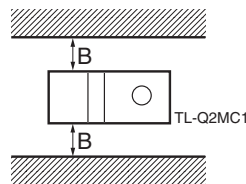
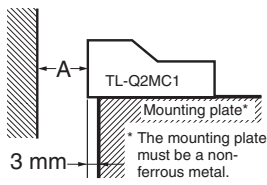

Influence of Surrounding Metal (Unit: mm)

| Model | Distance | A | B |
|----------|----------|----|---|
| TL-Q2MC1 | | 12 | 3 |

Grooved Model

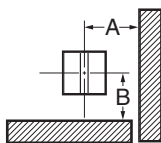

Influence of Surrounding Metal (Unit: mm)

| Model | Distance | A | B |
|----------|----------|----|----|
| TL-G3D-3 | | 11 | 17 |

Mutual Interference

When installing Sensors face-to-face or side-by-side, ensure that the minimum distances given in the following table are maintained.

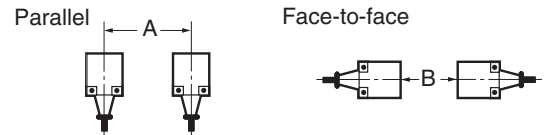

Mutual Interference (Unit: mm)

| Model | Distance | A * | B * |
|----------------------|----------|-----------|-----------|
| TL-Q5MC□ | | 60 (17) | 120 (60) |
| TL-Q5MD□ | | 60 (30) | 120 (80) |
| TL-N7MD□ | | 100 (50) | 120 (60) |
| TL-N12MD□ | | 120 (60) | 200 (100) |
| TL-N20MD□ | | 200 (100) | 200 (100) |
| TL-N5ME□ | | 80 (40) | 80 (40) |
| TL-N5MY□ | | 80 (40) | 90 (40) |
| TL-N10ME□, TL-N10MY□ | | 120 (60) | 120 (60) |
| TL-N20ME□, TL-N20MY□ | | 200 (100) | 120 (60) |

* Values in parentheses apply to Sensors operating at different frequencies.

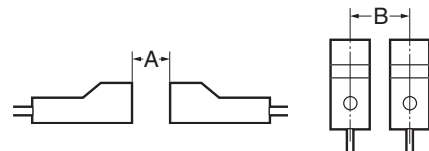

Mutual Interference (Unit: mm)

| Model | Distance | A | B |
|----------|----------|--------|---------|
| TL-Q2MC1 | | 30 (8) | 90 (45) |

Grooved Model

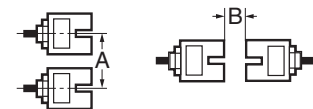

Mutual Interference (Unit: mm)

| Model | Distance | A | B |
|----------|----------|----|----|
| TL-G3D-3 | | 31 | 25 |

Designing the Sensing Object for TL-G3D-3 Grooved Model

For high-speed response to a toothed metal plate, the sensing objects must be at least the size of the standard sensing object and there must be sufficient distance between sensing objects. The response frequency for a toothed wheel like the one shown at the right is 1 kHz min. The response frequency will be reduced if the wheel is smaller or the width of the teeth or the distance between the teeth is reduced.

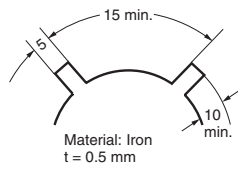

● Adjustment

Sensing Object Passing Position for the TL-G3D-3 Grooved Model

The gap between the sensing object and the bottom of the groove must be 1 mm or less.

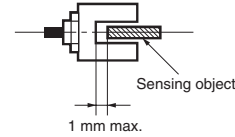

● Mounting

When tightening the mounting screws, do not exceed the torque in the following table.

| Model | Torque |
|----------|----------------|
| TL-Q2MC1 | 0.59 N·m |
| TL-Q5M□□ | |
| TL-N□M□□ | 0.9 to 1.5 N·m |
| TL-G3D-3 | 2 N·m |

Dimensions

(Unit: mm)
Tolerance class IT16 applies to dimensions in this data sheet unless otherwise specified.

Sensors

TL-Q2MC1

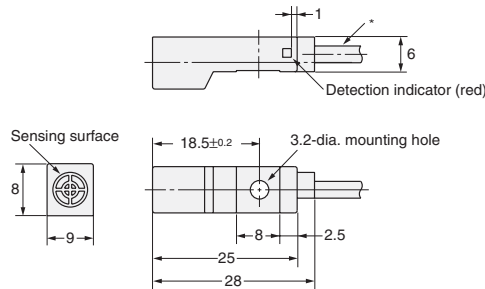
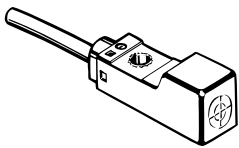

* 2.9-dia. vinyl-insulated round cable with 3 conductors (Conductor cross section: 0.15 mm², Insulator diameter: 0.9 mm), Standard length: 2 m

TL-Q5M□□

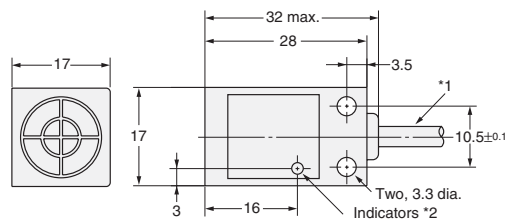
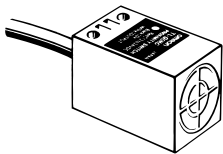

Mounting Hole Dimensions

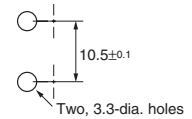

- *1. C Models: 4-dia. vinyl-insulated round cable with 3 conductors (Conductor cross section: 0.2 mm², Insulator diameter: 1.2 mm), Standard length: 2 m
- D Models: 4-dia. vinyl-insulated round cable with 2 conductors (Conductor cross section: 0.3 mm², Insulator diameter: 1.3 mm), Standard length: 2 m
- *2. C Models: Detection indicator (red)
- D Models: Operation indicator (red), Setting indicator (green)

TL-G3D-3

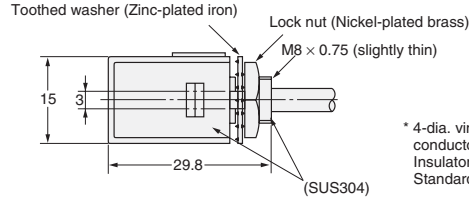
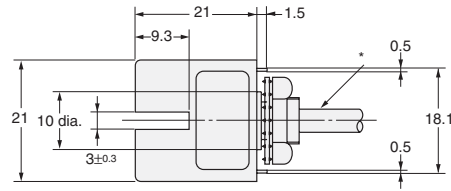
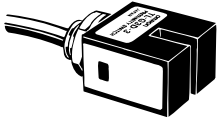

Mounting Hole Dimensions

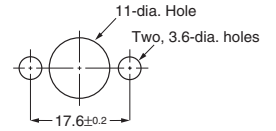

* 4-dia. vinyl-insulated round cable with 3 conductors (Conductor cross section: 0.2 mm², Insulator diameter: 1.2 mm), Standard length: 1 m

TL-N7MD□, TL-N5ME□

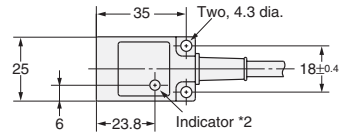
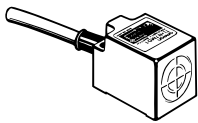

Mounting Hole Dimensions

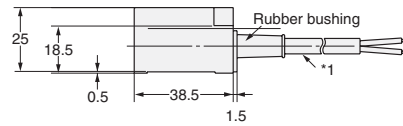
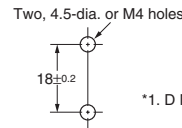

*1. D Models: 6-dia. vinyl-insulated round cable with 2 conductors (Conductor cross section: 0.5 mm², Insulator diameter: 1.9 mm), Standard length: 2 m
 E Models: 6-dia. vinyl-insulated round cable with 3 conductors (Conductor cross section: 0.5 mm², Insulator diameter: 1.9 mm), Standard length: 2 m
 *2. D1 Models: Operation indicator (red), Setting indicator (green)
 D2 Models: Operation indicator (red)
 E Models: Detection indicator (red)

TL-N5MY□

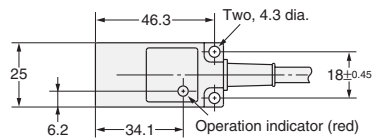
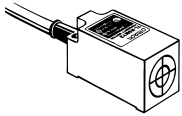

Mounting Hole Dimensions

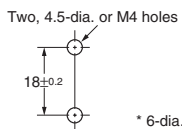

* 6-dia. vinyl-insulated round cable with 2 conductors (Conductor cross section: 0.5 mm², Insulator diameter: 1.9 mm), Standard length: 2 m

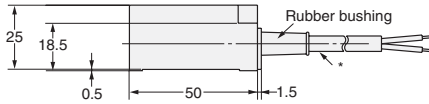

TL-N12MD□, TL-N10ME□, TL-N10MY□

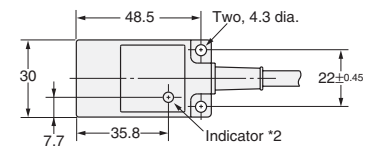
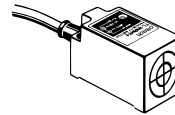

Mounting Hole Dimensions

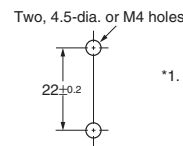

*1. D/Y Models: 6-dia. vinyl-insulated round cable with 2 conductors (Conductor cross section: 0.5 mm², Insulator diameter: 1.9 mm), Standard length: 2 m
 E Models: 6-dia. vinyl-insulated round cable with 3 conductors (Conductor cross section: 0.5 mm², Insulator diameter: 1.9 mm), Standard length: 2 m
 *2. D1 Models: Operation indicator (red) and Setting indicator (green)
 D2 Models: Operation indicator (red)
 E Models: Detection indicator (red)
 Y Models: Operation indicator (red)

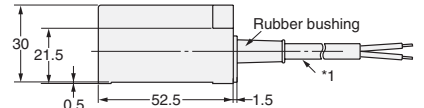

TL-N20MD□, TL-N20ME□, TL-N20MY□

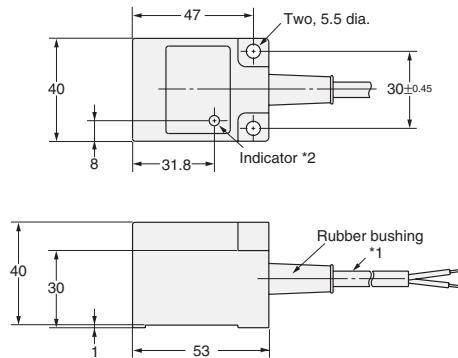
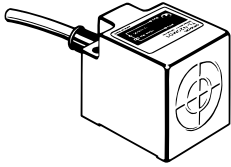

Mounting Hole Dimensions

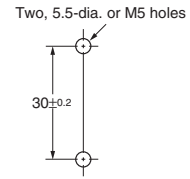

- *1. D/Y Models: 6-dia. vinyl-insulated round cable with 2 conductors (Conductor cross section: 0.5 mm², Insulator diameter: 1.9 mm), Standard length: 2 m
- E Models: 6-dia. vinyl-insulated round cable with 3 conductors (Conductor cross section: 0.5 mm², Insulator diameter: 1.9 mm), Standard length: 2 m
- *2. D1 Models: Operation indicator (red) and Setting indicator (green)
- D2 Models: Operation indicator (red)
- E Models: Detection indicator (red)
- Y Models: Operation indicator (red)

Accessories (Order Separately)

Mounting Bracket

Y92E-C5

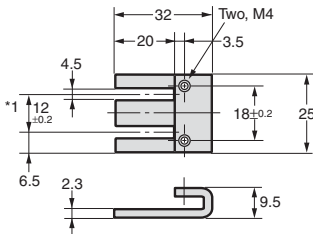

Applicable Models: TL-N5ME□ *2
 Applicable Models: TL-N5MY□
 Applicable Models: TL-N7MD□ *2
 Material: Mounting Bracket: Zinc-plated iron
 Mounting phillips Screws: Nickel-plated iron

Y92E-C10

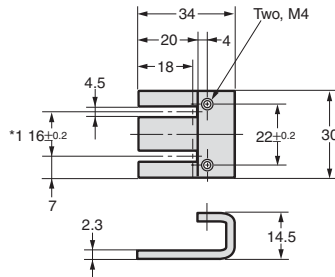

Applicable Models: TL-N10ME□ *2
 Applicable Models: TL-N10MY□
 Applicable Models: TL-N12MD□ *2
 Material: Mounting Bracket: Zinc-plated iron
 Mounting phillips Screws: Nickel-plated iron

Y92E-C20

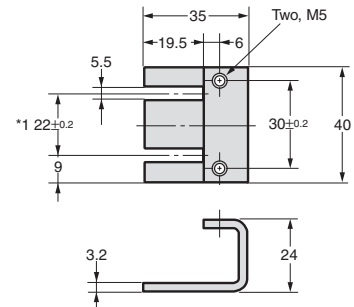

Applicable Models: TL-N20ME□ *2
 Applicable Models: TL-N20MY□
 Applicable Models: TL-N20MD□ *2
 Material: Mounting Bracket: Zinc-plated iron
 Mounting phillips Screws: Nickel-plated iron

*1. These are the mounting dimensions of the base of the Mounting Bracket.
 *2. Provided with the product.

Mounting Brackets for Wiring Conduit Use (Sold Separately)

Y92E-N5C15

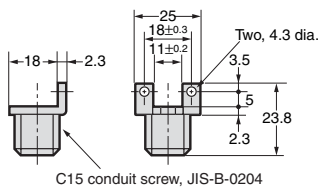

C15 conduit screw, JIS-B-0204
 Applicable Models: TL-N5ME□
 Applicable Models: TL-N5MY□
 Applicable Models: TL-N7MD□
 Material: Zinc-plated iron

Y92E-N10C15

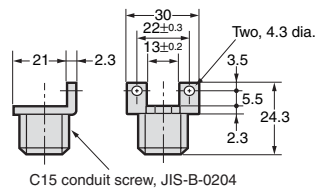

C15 conduit screw, JIS-B-0204
 Applicable Models: TL-N10ME□
 Applicable Models: TL-N10MY□
 Applicable Models: TL-N12MD□
 Material: Zinc-plated iron