

Rectangular Proximity Sensor TL-N

**A Variety of Models Available
for a Wide Range of Applica-
tions**

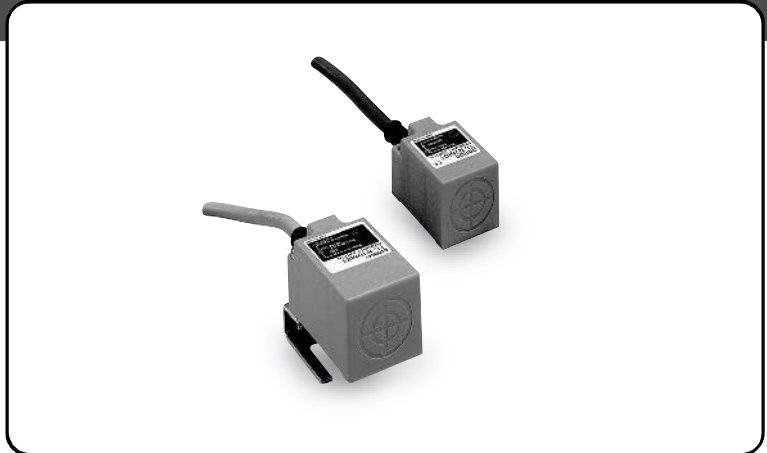

<READ AND UNDERSTAND THIS CATALOG>

Please read and understand this catalog before purchasing the products. Please consult your OMRON representative if you have any questions or comments.



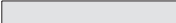

Ordering Information

■ TL-N□□MD DC 2-wire Models

Shield	Sensing distance	Operation mode	Model
Non-shielded 	 7 mm	NO	TL-N7MD1
		NC	TL-N7MD2
	 12 mm	NO	TL-N12MD1
		NC	TL-N12MD2
	 20 mm	NO	TL-N20MD1
		NC	TL-N20MD2

Note: Models with a different frequency are available to prevent mutual interference. The model numbers are TL-N□□MD□5 (e.g., TL-N7MD15).

■ DC 3-wire and AC 2-wire Models

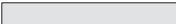
Shield	Sensing distance	Operation mode		Model		
Non-shielded 	 5 mm	DC 3-wire Models	NPN	NO	TL-N5ME1 (See notes 2 and 3.)	
			NPN	NC	TL-N5ME2 (See notes 2.)	
		AC 2-wire Models		NO	TL-N5MY1	
				NC	TL-N5MY2	
		 10 mm	DC 3-wire Models	NPN	NO	TL-N10ME1 (See notes 2 and 3.)
				NPN	NC	TL-N10ME2 (See notes 2.)
	AC 2-wire Models		NO	TL-N10MY1		
			NC	TL-N10MY2		
	 20 mm	DC 3-wire Models	NPN	NO	TL-N20ME1 (See notes 2 and 3.)	
			NPN	NC	TL-N20ME2	
		AC 2-wire Models		NO	TL-N20MY1	
				NC	TL-N20MY2	

Note 1. Models with a different frequency are available to prevent mutual interference. The model numbers are TL-N□□ME□5 (e.g., TL-N5ME15).

2. Each of these models has a cable with a standard length of 5 m.

3. Each of these models with a robot cable is available and classified with the suffix "R" added to the model number (e.g., TL-N5ME1-R).

Specifications

■ Ratings/Characteristics

TL-N□MD DC 2-wire Models

Item	TL-N7MD□	TL-N12MD□	TL-N20MD□
Power supply voltage (operating voltage range)	12 to 24 VDC (10 to 30 VDC), ripple (p-p): 10% max.		
Leakage current	0.8 mA max.		
Sensing object	Ferrous metal (Refer to <i>Engineering Data</i> for non-ferrous metal)		
Sensing distance	7 mm ±10%	12 mm ±10%	20 mm ±10%
Set distance (standard sensing object)	0 to 5.6 mm (iron, 30 x 30 x 1 mm)	0 to 9.6 mm (iron, 40 x 40 x 1 mm)	0 to 16 mm (iron, 50 x 50 x 1 mm)
Differential travel	10% max. of sensing distance		
Response speed (See note.)	0.5 kHz		0.3 kHz
Operation mode (with sensing object approaching)	D1 Models: NO D2 Models: NC		
Control output	Load current	3 to 100 mA DC	
	Residual voltage	3.3 V max. (Load current: 100 mA , Cable length: 2 m)	
Protection circuits	Short-circuit protection and surge suppressor		
Indicator	D1 Models: Operation indicator (red LED) and setting indicator (green LED) D2 Models: Operation indicator (red LED)		
Ambient temperature	Operating/storage: -25°C to 70°C (with no icing or condensation)		
Ambient humidity	Operating/storage: 35% to 95%		
Temperature influence	±10% max. of sensing distance at 23°C in the temperature range of -25°C to 70°C		
Voltage influence	±2.5% max. of sensing distance in the rated voltage range ±15%		
Insulation resistance	50 MΩ min. (at 500 VDC) between current-carrying parts and case		
Dielectric strength	1,000 VAC for 1 min between current-carrying parts and case		
Vibration resistance	10 to 55 Hz, 1.5-mm double amplitude for 2 hours each in X, Y, and Z directions		
Shock resistance	1,000 m/s ² 10 times each in X, Y, and Z directions		
Degree of protection	IEC 60529 IP67		
Weight (with 2-m cable)	Approx. 145 g	Approx. 170 g	Approx. 240 g
Material	Case	Heat-resistant ABS resin	
	Sensing surface	Heat-resistant ABS resin	

Note: The response speed is an average value. Measurement conditions are as follows: standard sensing object, a distance of twice the standard sensing objects, and a set distance of half the sensing distance.

DC 3-wire and AC 2-wire Models

Item		TL-N5ME□, TL-N5MY□	TL-N10ME□, TL-N10MY□	TL-N20ME□, TL-N20MY□
Power supply voltage (operating voltage range) (See note 1.)		E Models: 12 to 24 VDC (10 to 30 VDC), ripple (p-p): 10% max. Y Models: 100 to 220 VAC (90 to 250 VAC), 50/60 Hz		
Current consumption		E Models: 8 mA at 12 V, 15 mA at 24 V		
Leakage current		Y Models: Refer to <i>Engineering Data</i> .		
Sensing object		Ferrous metal (Refer to <i>Engineering Data</i> for non-ferrous metal)		
Sensing distance		5 mm ±10%	10 mm ±10%	20 mm ±10%
Set distance (standard sensing object)		0 to 4 mm (iron, 30 x 30 x 1 mm)	0 to 8 mm (iron, 40 x 40 x 1 mm)	0 to 16 mm (iron, 50 x 50 x 1 mm)
Differential travel		15% max. of sensing distance		
Response speed (See note 2.)		E Models: 500 Hz Y Models: 10 Hz		E Models: 40 Hz Y Models: 10 Hz
Operation mode (with sensing object approaching)		E1 Models: NO E2 Models: NC Y1 Models: NO Y2 Models: NC		
Control output	Load current	E Models: 100 mA max. at 12 VDC, 200 mA max. at 24 VDC Y Models: 10 to 200 mA		
	Residual voltage	E Models: 1 V max. (Load current: 200 mA) Y Models: Refer to <i>Engineering Data</i> .		
Protection circuits		E Models: Reverse polarity protection and surge suppressor Y Models: Surge suppressor		
Ambient temperature		Operating/storage: -25°C to 70°C (with no icing or condensation)		
Ambient humidity		Operating/storage: 35% to 95%		
Temperature influence		±10% max. of sensing distance at 23°C in the temperature range of -25°C to 70°C		
Voltage influence		E Models: ±2.5% max. of sensing distance in the rated voltage range ±10% Y Models: ±1% max. of sensing distance in the rated voltage range ±10%		
Insulation resistance		50 MΩ min. (at 500 VDC) between current-carrying parts and case		
Dielectric strength		DC Models: 1,000 VAC, 50/60 Hz for 1 min between current-carrying parts and case AC Models: 2,000 VAC, 50/60 Hz for 1 min between current-carrying parts and case		
Vibration resistance		10 to 55 Hz, 1.5-mm double amplitude for 2 hours each in X, Y, and Z directions		
Shock resistance		500 m/s ² 10 times each in X, Y, and Z directions		
Degree of protection		IEC 60529: IP67		
Weight (with 2-m cable)		Approx. 145 g	Approx. 170 g	Approx. 240 g
Material	Case	Heat-resistant ABS resin		
	Sensing surface	Heat-resistant ABS resin		

Note: The response speed is an average value. Measurement conditions are as follows: standard sensing object, a distance of twice the standard sensing objects, and a set distance of half the sensing distance.

Engineering Data

Operating Range (Typical)

TL-N□ME, TL-N□MY

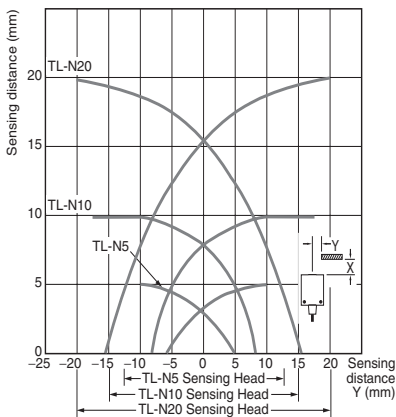

TL-N□MD DC 2-wire Models

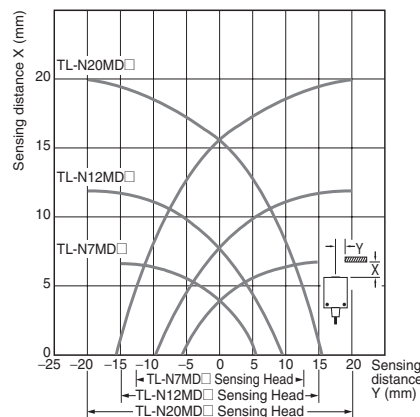

Output Residual Voltage Characteristics (Typical)

TL-N□MD DC 2-wire Models

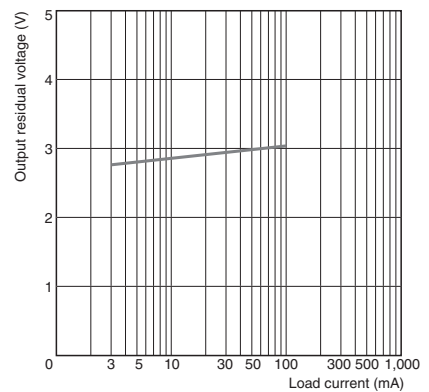

Sensing Object Size and Material vs. Sensing Distance (Typical)

TL-N5

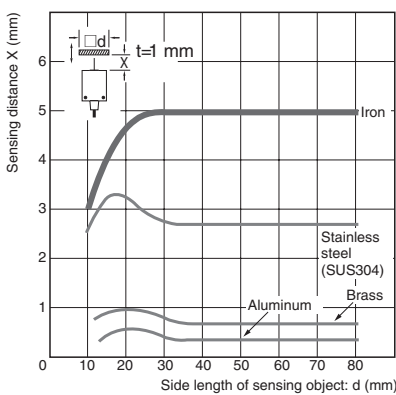

TL-N7MD DC 2-wire Models

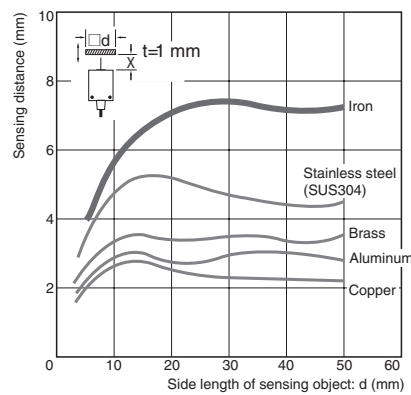

TL-N12MD DC 2-wire Models

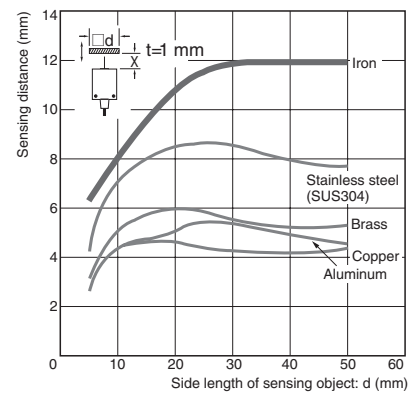

TL-N20MD DC 2-wire Models

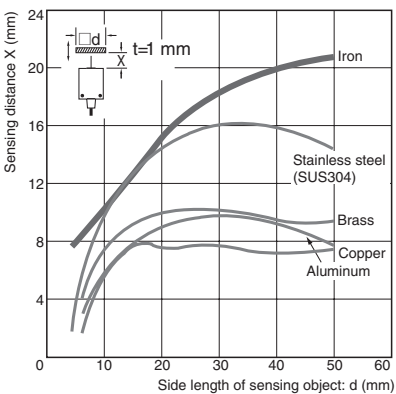

TL-N10

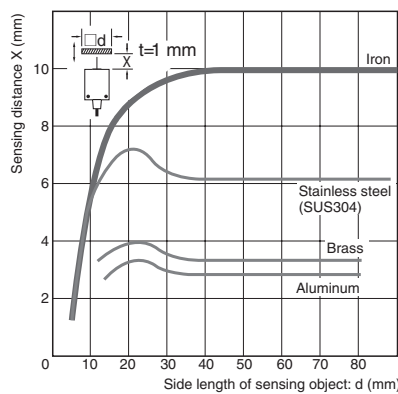

TL-N20

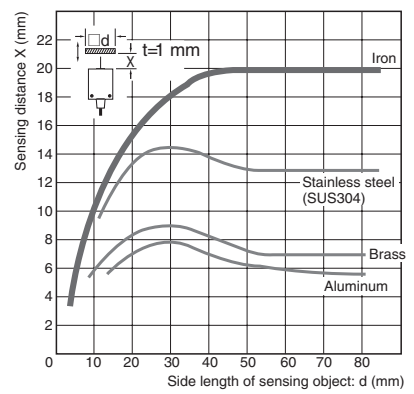

Leakage Current Characteristics (Typical)

TL-N□MY

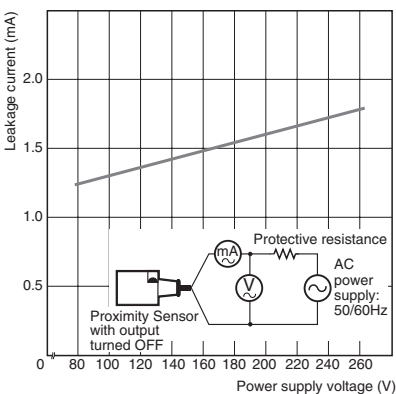

Operation

Output Circuits

DC 2-wire Models

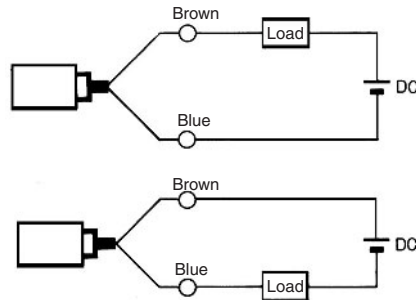
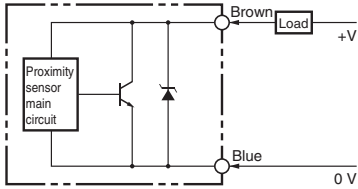

Note: The load can be connected in two ways as shown in the above diagrams.

Timing Charts

Normally Open Model

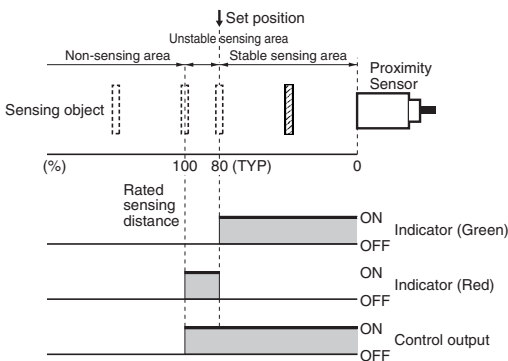

Normally Closed Model

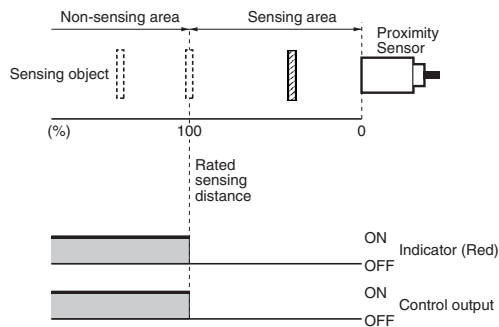

DC 3-wire Models

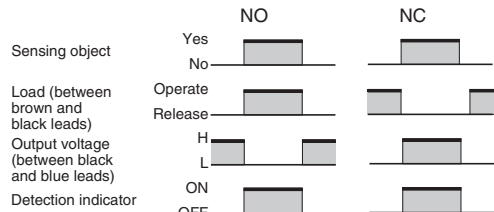
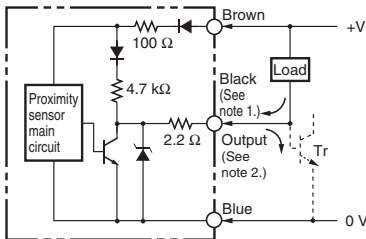

Note 1. 200 mA max. (load current)
Note 2. When a transistor is connected.

AC 2-wire Models

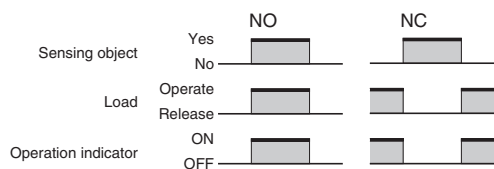
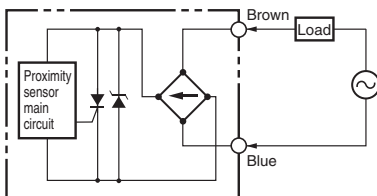

Precautions

⚠ WARNING

Do not use this Sensor in applications related to human safety.

This product is not designed or rated for ensuring safety of persons. Do not use it for such purposes.

Do not short-circuit the load, otherwise the TL-N may be damaged. Do not supply power to the TL-N with no load, otherwise the TL-N may be damaged.

Applicable Models: AC 2-wire Models

■ Precautions for Correct Use

Influence of Surrounding Metals

When the TL-N is surrounded by metal, keep at least the following distances between the TL-N and the metal.

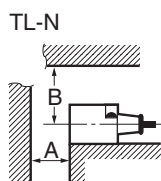

(Unit: mm)

Distance	TL-N7MD□	TL-N12MD□	TL-N20MD□	TL-N5ME□ TL-N5MY□	TL-N10ME□ TL-N10MY□	TL-N20ME□ TL-N20MY□
A (See note.)	40	50	70	20	40	80
B (See note.)	35	40	60	23	30	45

Note: The figures are applicable for one metal object, otherwise the figure must be multiplied by the number of metal objects.

Mutual Interference

When two or more Sensors are mounted face-to-face or side-by-side, keep them separated at the following distances or greater.

Side-by side

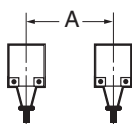

Face-to-face

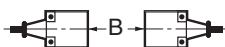

(Unit: mm)

Distance	TL-N7MD□	TL-N12MD□	TL-N20MD□	TL-N5ME□	TL-N5MY□	TL-N10ME□ TL-N10MY□	TL-N20ME□ TL-N20MY□
A	100 (50)	120 (60)	200 (100)	80 (40)	80 (40)	120 (60)	200 (100)
B	120 (60)	200 (100)	200 (100)	80 (40)	90 (40)	120 (60)	120 (60)

Note: Figures in parentheses will apply if the Sensors in use are different to each other in response speed.

Mounting

Make sure that each screw is tightened with a torque within a range of 0.9 to 1.5 N·m.

Dimensions

Note: All units are in millimeters unless otherwise indicated.

TL-N7MD

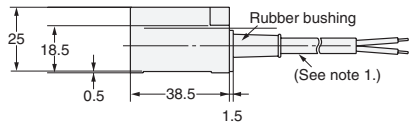
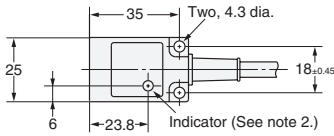
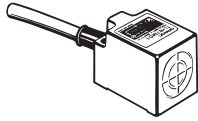

- Note 1.** 6-dia. vinyl-insulated round cable with 2 conductors (Conductor cross section: 0.5 mm², Insulator diameter: 1.9 mm dia.), Standard length: 2 m
- D1 Models: Operation indicator (red) and setting indicator (green)
D2 Models: Operation indicator (red)
 - The Y92E-C5 Mounting Bracket is provided with the TL-N7MD.

TL-N12MD

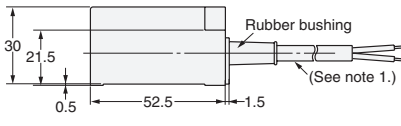
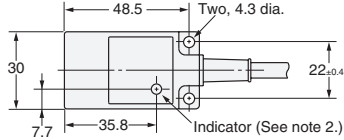
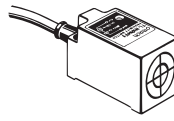

- Note 1.** 6-dia. vinyl-insulated round cable with 2 conductors (Conductor cross section: 0.5 mm², Insulator diameter: 1.9 mm dia.), Standard length: 2 m
- D1 Models: Operation indicator (red) and setting indicator (green)
D2 Models: Operation indicator (red)
 - The Y92E-C10 Mounting Bracket is provided with the TL-N12MD.

TL-N20MD

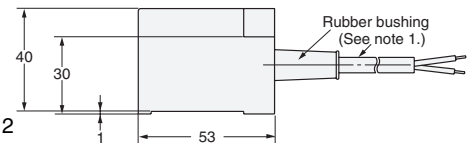
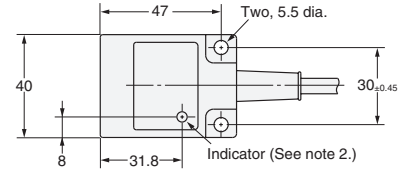
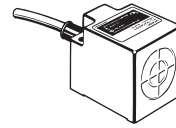

- Note 1.** 6-dia. vinyl-insulated round cable with 2 conductors (Conductor cross section: 0.5 mm², Insulator diameter: 1.9 mm dia.), Standard length: 2 m
- D1 Models: Operation indicator (red) and setting indicator (green)
D2 Models: Operation indicator (red)
 - The Y92E-C20 Mounting Bracket is provided with the TL-N20MD.

TL-N5MY

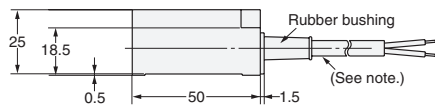
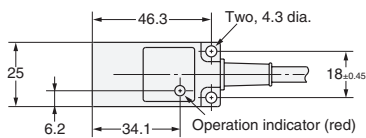
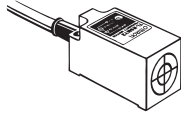

- Note 1.** 6-dia. vinyl-insulated round cable with 2 conductors (Conductor cross section: 0.5 mm², Insulator diameter: 1.9 mm dia.), Standard length: 2 m

TL-N5ME

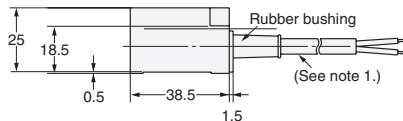
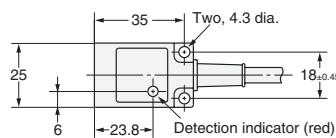
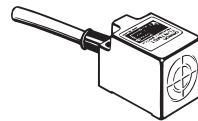

- Note 1.** 6-dia. vinyl-insulated round cable with 3 conductors (Conductor cross section: 0.5 mm², Insulator diameter: 1.9 mm dia.), Standard length: 2 m
- The Y92E-C5 Mounting Bracket is provided with the TL-N5ME.

TL-N10ME/N10MY

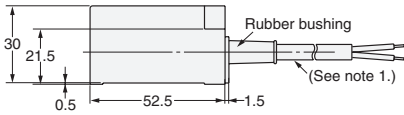
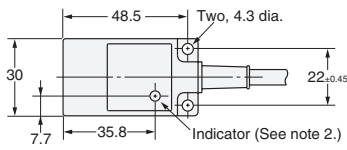
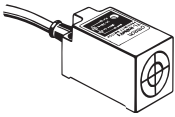

- Note 1.** E Models: 6-dia. vinyl-insulated round cable with 3 conductors (Conductor cross section: 0.5 mm², Insulator diameter: 1.9 mm dia.), Standard length: 2 m
 Y Models: 6-dia. vinyl-insulated round cable with 2 conductors (Conductor cross section: 0.5 mm², Insulator diameter: 1.9 mm dia.), Standard length: 2 m
- 2.** E Models: Detection indicator (red)
 Y Models: Operation indicator (red)
- 3.** The Y92E-C10 Mounting Bracket is provided with the TL-N10ME□.

TL-N20ME/N20MY

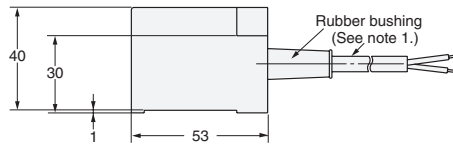
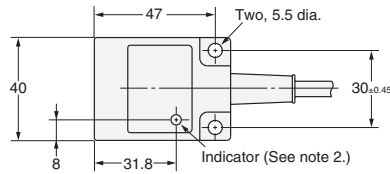
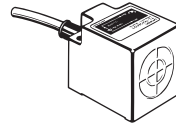

- Note 1.** E Models: 6-dia. vinyl-insulated round cable with 3 conductors (Conductor cross section: 0.5 mm², Insulator diameter: 1.9 mm dia.), Standard length: 2 m
 Y Models: 6-dia. vinyl-insulated round cable with 2 conductors (Conductor cross section: 0.5 mm², Insulator diameter: 1.9 mm dia.), Standard length: 2 m
- 2.** E Models: Detection indicator (red)
 Y Models: Operation indicator (red)
- 3.** The Y92E-C20 Mounting Bracket is provided with the TL-N20ME□.

Mounting Holes

TL-N5ME/N5MY/N7MD

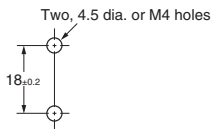

TL-N10ME/N10MY/N12MD

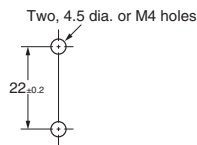

TL-N20ME/N20MY/N20MD

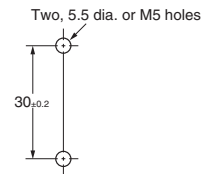

Mounting Brackets

The Mounting Bracket is provided with TLN□-ME□/D□ DC models. The Mounting Bracket as an optional accessory is available to all models.

Y92E-C5

Applicable Models: TL-N5ME, TL-N5MY, and TL-N7MD

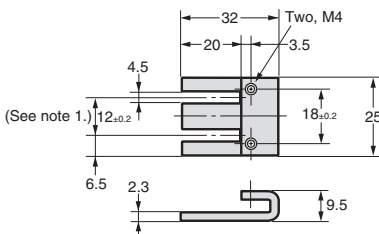

Y92E-C10

Applicable Models: TL-N10ME, TL-N10MY, and TL-N12MD

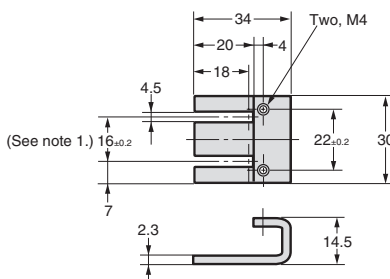

Y92E-C20

Applicable Models: TL-N20ME, TL-N20MY, and TL-N20MD

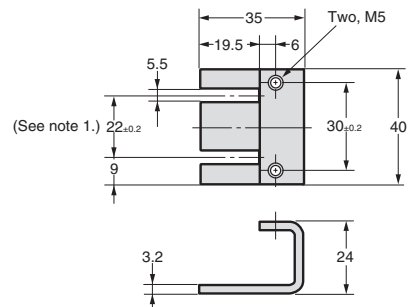

Note: These are the mounting dimensions of the base of the Mounting Bracket.

Mounting Brackets for Wiring Conduit Use (Sold Separately)

Y92E-N5C15

Applicable Models: TL-N5ME, TL-N5MY, and TL-N7MD

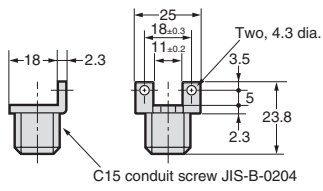

Y92E-N10C15

Applicable Models: TTL-N10ME, TL-N10MY, and TL-N12MD

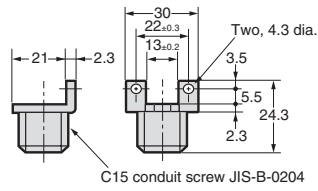

Warranties and Limitations of Liability

■ WARRANTY

OMRON's exclusive warranty is that the products are free from defects in materials and workmanship for a period of one year (or other period if specified) from date of sale by OMRON.

OMRON MAKES NO WARRANTY OR REPRESENTATION, EXPRESS OR IMPLIED, REGARDING NON-INFRINGEMENT, MERCHANTABILITY, OR FITNESS FOR PARTICULAR PURPOSE OF THE PRODUCTS. ANY BUYER OR USER ACKNOWLEDGES THAT THE BUYER OR USER ALONE HAS DETERMINED THAT THE PRODUCTS WILL SUITABLY MEET THE REQUIREMENTS OF THEIR INTENDED USE. OMRON DISCLAIMS ALL OTHER WARRANTIES, EXPRESS OR IMPLIED.

■ LIMITATIONS OF LIABILITY

OMRON SHALL NOT BE RESPONSIBLE FOR SPECIAL, INDIRECT, OR CONSEQUENTIAL DAMAGES, LOSS OF PROFITS OR COMMERCIAL LOSS IN ANY WAY CONNECTED WITH THE PRODUCTS, WHETHER SUCH CLAIM IS BASED ON CONTRACT, WARRANTY, NEGLIGENCE, OR STRICT LIABILITY.

In no event shall responsibility of OMRON for any act exceed the individual price of the product on which liability is asserted.

IN NO EVENT SHALL OMRON BE RESPONSIBLE FOR WARRANTY, REPAIR, OR OTHER CLAIMS REGARDING THE PRODUCTS UNLESS OMRON'S ANALYSIS CONFIRMS THAT THE PRODUCTS WERE PROPERLY HANDLED, STORED, INSTALLED, AND MAINTAINED AND NOT SUBJECT TO CONTAMINATION, ABUSE, MISUSE, OR INAPPROPRIATE MODIFICATION OR REPAIR.

Application Considerations

■ SUITABILITY FOR USE

THE PRODUCTS CONTAINED IN THIS CATALOG ARE NOT SAFETY RATED. THEY ARE NOT DESIGNED OR RATED FOR ENSURING SAFETY OF PERSONS, AND SHOULD NOT BE RELIED UPON AS A SAFETY COMPONENT OR PROTECTIVE DEVICE FOR SUCH PURPOSES. Please refer to separate catalogs for OMRON's safety rated products.

OMRON shall not be responsible for conformity with any standards, codes, or regulations that apply to the combination of products in the customer's application or use of the product.

Take all necessary steps to determine the suitability of the product for the systems, machines, and equipment with which it will be used.

Know and observe all prohibitions of use applicable to this product.

NEVER USE THE PRODUCT FOR AN APPLICATION INVOLVING SERIOUS RISK TO LIFE OR PROPERTY WITHOUT ENSURING THAT THE SYSTEM AS A WHOLE HAS BEEN DESIGNED TO ADDRESS THE RISKS, AND THAT THE OMRON PRODUCT IS PROPERLY RATED AND INSTALLED FOR THE INTENDED USE WITHIN THE OVERALL EQUIPMENT OR SYSTEM.

Disclaimers

■ CHANGE IN SPECIFICATIONS

Product specifications and accessories may be changed at any time based on improvements and other reasons. Consult with your OMRON representative at any time to confirm actual specifications of purchased product.

■ DIMENSIONS AND WEIGHTS

Dimensions and weights are nominal and are not to be used for manufacturing purposes, even when tolerances are shown.

ALL DIMENSIONS SHOWN ARE IN MILLIMETERS.

To convert millimeters into inches, multiply by 0.03937. To convert grams into ounces, multiply by 0.03527.

OMRON Corporation
Industrial Automation Company
Sensing Devices Division H.Q.
Industrial Sensors Division

Shiokoji Horikawa, Shimogyo-ku,
Kyoto, 600-8530 Japan
Tel: (81)75-344-7022/Fax: (81)75-344-7107

Regional Headquarters

OMRON EUROPE B.V.
Sensor Business Unit
Carl-Benz-Str. 4, D-71154 Nufringen,
Germany
Tel: (49) 7032-811-0/Fax: (49) 7032-811-199

OMRON ELECTRONICS LLC
One Commerce Drive Schaumburg,
IL 60173-5302 U.S.A.
Tel: (1) 847-843-7900/Fax: (1) 847-843-7787

OMRON ASIA PACIFIC PTE. LTD.
No. 438A Alexandra Road # 05-05/08 (Lobby 2),
Alexandra Technopark, Singapore 119967
Tel: (65) 6835-3011/Fax: (65) 6835-2711

OMRON (CHINA) CO., LTD.
Room 2211, Bank of China Tower,
200 Yin Cheng Zhong Road,
PuDong New Area, Shanghai, 200120, China
Tel: (86) 21-5037-2222/Fax: (86) 21-5037-2200

Authorized Distributor:

© OMRON Corporation 2008 All Rights Reserved.
In the interest of product improvement,
specifications are subject to change without notice.

CSM_1_2_0709
Cat. No. D079-E1

Printed in Japan
0508